



nobiscolimited

ESSENTIALS CATALOGUE

2026

Contents

Equipment

Food Preparation 6

Drinks & Dessert Preparation 30

Cooking Equipment 46

Heating & Holding 78

Insulated Food Delivery 94

Icemaking 110

Refrigeration 120

Warewashing 132

Shelving & Trolleys 142

Smallwares

Food Storage 158

Cookware & Bakeware 178

Personal Safety & Janitorial 192

Kitchen Utensils 200

Trays 216

Table Service & Display 226

Dispensing & Serving 242

FOR OUR FULL
PRODUCT RANGE
VISIT FEM.CO.UK

Our Partners



ALTO-SHAAM

Leading provider of foodservice equipment solutions featuring game-changing technology, innovative controls and design guaranteed to give you tastier outputs and a greater return on investment.



CAMBRO

TRUSTED DURABILITY

Cambro serves up the industry's most complete selection of products for the most diverse foodservice businesses making them the world's foremost manufacturer of plastic foodservice products.



NEW
BRAND
SEE PAGE
122

G+ BY GRAM PROFESSIONAL

Gram Professional is a leading manufacturer of high-quality, energy-efficient refrigeration solutions for professional kitchens, delivering reliable performance and consistent food storage.



HAMILTON BEACH COMMERCIAL

Leading manufacturers of top-performing, durable foodservice drinks blenders, food blenders and mixers that easily stand up to the rigorous use of a commercial kitchen.



Manitowoc

FROM PENTAIR WATER SOLUTIONS

An industry leader for food safety and environmental stewardship in ice manufacturing offering the largest range of ENERGY STAR® rated ice machines in the market.



NEW
BRAND
SEE PAGE
48

PRATICA

Leading manufacturer of high-speed ovens, delivering fast, reliable, and consistent results for professional kitchens while helping chefs streamline operations.



PRINCECASTLE

Leader in holding, steaming, toasting, and smallwares technology, delivering reliable, high-performance solutions that help the world's leading restaurant chains maintain consistency, efficiency, and quality in their kitchens.



san jamar

smart. safe. sanitary.

San Jamar, a CFS brand, is a world leader in smart disposables, dispensing, and food safety equipment, helping make foodservice operations safer, more sanitary, and more efficient.



SIRMAN

Leading manufacturer of heavy-duty and dependable innovations for food preparation and high-quality cooking which continue to exceed the demands of foodservice operations of any size.



pujadas

A VOLLRATH COMPANY

Leading providers in the development of high-quality and eye-catching professional cookware and table and displayware equipment for the catering and hospitality sector.



SERVER

Industry-leading dispensing equipment for the foodservice industry with solutions offering smart, efficient and sustainable ways to serve fresh food.



VOLLRATH

Our founding partner - industry leaders in stainless steel smallwares and cooking equipment with an onus on energy-efficient and long-lasting products for the catering sector.

New Products

PCT Timers 27



BCR200 Container Rinsers 38



Pratica FIT High Speed Ovens 49



Ventless Self-Cleaning Air Fryer 55



Pro Cart Ultra™ Low Profile Pan Carrier 96



NEO Icemakers with Integrated Water Filtration 114



Compact Cabinet Refrigerators & Freezers 123



Gastro Counter Refrigerators & Freezers 126



SafeTrak™ GN Food Pans 170



Polypropylene CamRound™ FreshPro Containers 171



INOX FIRST Cookware 180



Buffet Trolleys 228



WELCOME

Featured Brands



Food Preparation

A great meal starts with great preparation. It's a balancing act: sourcing fresh local ingredients, keeping costs down, reducing waste, and having the right tools for the job. Your food preparation equipment should be high-quality, reliable, and suited to your workflow. Whether slicing, dicing, mixing, chopping, or emulsifying, we have the perfect tools to assist every step of preparation. Browse our leading range of durable and innovative food preparation equipment and make every kitchen task easier and more efficient.



Stick Blenders	8
Food Blenders	10
Vegetable Processors	12
Food Processors	13
Planetary Mixers	14
Slicers	16
Burger Presses	19
Cheese Graters	19
Pasta Machines	20
Pasta Sheeters	20
Dough Mixers	21
Dough Rollers	21
Meat Mincers	22
Vacuum Packers	23
Bag Sealers	26
Shrink Wrapper	26
Tray Thermosealer	26
UV Steriliser Cabinets	26
Kitchen Timers	27
Manual Food Preparation Tools	28

Mini BigRig™ Compact Stick Blender



**NEW
MINI BIGRIG™
MODEL ADDED
TO RANGE**

**WARRANTY
2
YEARS
PARTS & LABOUR**

**VARIABLE SPEED DIAL
FOR GREATER
BLENDING CONTROL**

**EASY LOCK/UNLOCK
DETACHES WITH A TWIST
FOR EASY CLEANUP**

- Quickly blend, liquify and puree with a powerful 250-watt motor.
- 9" (230mm) shaft is ideal for preparing smaller food batches up to 11L.
- Variable speed dial provides greater control over the texture of sauces, purees, soups and emulsions.
- Easy-to-use, ergonomic design provides maximum blending control.
- Easy lock, unlock – shaft securely locks in place and detaches with a twist for easy cleanup.
- High-visibility 8 Ft./ 240cm yellow power cord helps ensure safety in busy kitchens.

Mini BigRig™ Compact Stick Blender Ideal for small batches and other light-duty use.

CODE	POWER	RPM	CAPACITY	SHAFT	W x D x H
HMI009-UK	0.25kw	5,000 – 18,000	11L	230mm	89 x 89 x 530mm

*SUPPLIED WITH 13A PLUG

BigRig™ Stick Blenders



**DETACHABLE STAINLESS
STEEL SHAFT WITH
ERGONOMIC GRIP**



**ERGONOMIC DESIGN WITH
LIGHT-TOUCH CONTROLS
OFFER MULTIPLE HAND
POSITIONS FOR COMFORT**



**THUMBDRIVE™ VARIABLE
SPEED DIAL WITH
COLOURCODED LIGHT FOR
IMMEDIATE FEEDBACK**

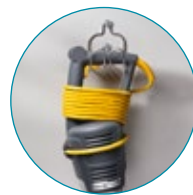

**WALL MOUNT AND CORD
HOLDER FOR NEAT, EASY
STORAGE**

**WARRANTY
2
YEARS
PARTS & LABOUR**

**BEST-IN-CLASS
COMMERCIAL
WARRANTY**

- Incredibly fast results for blending, pureeing, emulsifying, and whipping, and much more.
- Powerful 1 HP motor.
- Unique 2-position handle and ergonomic shaft grip maximises blending comfort and control.
- Variable speed dial has colour-coded light for immediate feedback.
- 100% sealed stainless steel shaft easily removes for changing or cleaning; 5 interchangeable shaft lengths available.
- Patent-pending speed dial with colour-coded light providing blending precision.
- Continuous run operation for high-volume blending.
- High-visibility 12 ft./365cm yellow power cord.
- Unit comes with power base, stainless steel shaft and wall-mount hanger.

BigRig™ Stick Blenders

CODE	POWER	RPM	CAPACITY	SHAFT	W x D x H
HMI012-UK	1kw	3,000 – 15,000	23L	305mm	216 x 140 x 780mm
HMI014-UK	1kw	3,000 – 15,000	53L	355mm	216 x 140 x 820mm
A HMI016-UK	1kw	3,000 – 15,000	87L	406mm	216 x 140 x 880mm
HMI018-UK	1kw	3,000 – 15,000	121L	457mm	216 x 140 x 930mm
B HMI021-UK	1kw	3,000 – 15,000	158L	533mm	216 x 140 x 1000mm

*ALL MODELS SUPPLIED WITH 13A PLUG.

Accessories

CODE	DESCRIPTION
HMIS12	BigRig 305mm Shaft
HMIS14	BigRig 355mm Shaft
HMIS16	BigRig 406mm Shaft
HMIS18	BigRig 457mm Shaft
HMIS21	BigRig 533mm Shaft
HMI02W	Big Rig Whisk 110 x 490mm

Storm & Ciclone Stick Blenders



- Highly effective patented cooling system.
- Sturdy and lightweight fibreglass ABS body.
- Ergonomic handle.
- Safety device preventing switching on by mistake.
- Trigger switch for continuous blending.
- IPX3 protection.
- Quick coupling device.
- Cutlery steel knives.

Storm & Ciclone Stick Blenders

CODE	POWER	RPM	CAPACITY	SHAFT	W X D X H
A STORM	0.2kw	12,500	15L	160mm	74 x 145 x 450mm
CICLONE 200	0.2kw	16,000	20L	250mm	100 x 182 x 590mm
B CICLONE 280	0.28kw	16,000	40L	350mm	100 x 182 x 660mm
CICLONE 360	0.36kw	16,000	70L	350mm	100 x 182 x 688mm

*ALL MODELS SUPPLIED WITH  13A PLUG.

Accessories

CODE	DESCRIPTION
S STICK 160	Spare 160mm Storm Shaft
C STICK 250	Spare 250mm Ciclone Shaft
C STICK 350	Spare 350mm Ciclone Shaft
C WHISK	Spare 348mm Ciclone Whisk



Vortex Stick Blenders

REMOVABLE RODS
FOR THROUGH
CLEANING &
LONG-LASTING
PERFORMANCE



- Highly effective patented cooling system.
- Sturdy and lightweight fibreglass ABS body.
- Practical and ergonomic handle.
- Rubber buffer between motor and shaft.
- Powerful performance engine for heavy-duty operations.
- IPX3 protection.
- Quick coupling device.
- Completely demountable shafts for an accurate cleaning and a longer life.
- Completely stainless steel shaft and bell.
- Integrated electronic switch to avoid accidental switch on of the motor.

Vortex Heavy Duty Stick Blenders

CODE	POWER	RPM	CAPACITY	SHAFT	W x D x H
VORTEX 430	0.43kw	13,000	100L	350mm	125 x 190 x 727mm
VORTEX 550	0.55kw	13,500	200L	450mm	125 x 190 x 835mm
VORTEX 750	0.75kw	14,000	300L	450mm	125 x 190 x 840mm

*ALL MODELS SUPPLIED WITH  13A PLUG.

Accessories

CODE	DESCRIPTION
V STICK 350	Spare 350mm Shaft
V STICK 450	Spare 450mm Shaft
V WHISK	Spare 385mm Whisk



Variable Speed Vortex Heavy Duty Blenders

CODE	RPM
VORTEX 430 VT	2,000 - 11,500
VORTEX 550 VT	2,000 - 11,500
VORTEX 750 VT	2,000 - 11,500

EXPEDITOR™ 510 Food Blender



FOOD PREPARATION



NEW DESIGN!



LID OPEN SENSOR PREVENTS BLENDING WHEN LID IS NOT ON



SEALED PADDLE SWITCHES ARE LEAK RESISTANT

- Chop, variable speed and pulse functions for easy chopping, grinding, blending, puréeing & emulsifying.
- Powerful 2.4 Hp motor lets user blend ingredients quickly and optimises blending consistency.
- High-strength stainless steel blade quickly powers through ingredients.
- Durable metal drive coupling provides long-lasting performance for uninterrupted use.
- Large dosing cup makes adding liquid for emulsions easy while blending hot and cold food.
- Jar alignment sensor's indicator light flashes when the jar is misaligned, preventing blending.
- Protective brow directs drips away from controls.

2.4HP Expeditor Food Blenders

CODE	MOTOR	CONTAINER	CAP.	W X D X H
HBF510-UK	2.4 HP	Co-polyester	1.4L	190 x 210 x 490mm
HBF510S-UK	2.4 HP	Stainless Steel	1.8L	190 x 210 x 515mm

*ALL MODELS SUPPLIED WITH 13A PLUG.

2.4HP Expeditor Food Blender Accessories

CODE	DESCRIPTION
6126-455-CE	Spare 1.4L BPA Free Co-polyester Container
6126-510S-CE	Spare 1.8L Stainless Steel Container

EXPEDITOR™ 600R Food Blender



NEW & IMPROVED DESIGN



ONE-TOUCH CHOPPING FUNCTION



JAR PAD SENSOR PREVENTS BLENDING WHEN LID IS NOT ON

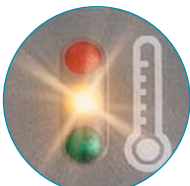

TEMPERATURE GAUGE ALERTS OPERATOR IF MOTOR OVERHEATS WHILE BLENDING

- Unique one-touch chopping function with speed control gives chefs ultimate control over food consistency.
- Powerful 3 peak* HP motor lets chefs chop salsa and compotes, grind flour, puree soups, emulsify dressings and more.
- Intuitive touchpad with variable speed dial to control consistency and speed with precision.
- 64 oz. / 1.8 L BPA-free co-polyester container with laser-etched measurements that last a lifetime.
- Extremely durable all-metal drive coupling with jar pad sensor to help extend coupling life.
- Large Dosing Cup Makes adding liquids for emulsions easy while blending.
- Patented Wave-Action® System keeps ingredients circulating through the blades to ensure that contents are fully emulsified.
- Sealed Lid Prevents Leaks with an easy-to-lift tab and dosing cup.

EXPEDITOR™ 600R Food Blender

CODE	MOTOR	CONTAINER	CAP.	W X D X H
HBF600R-CE	3 HP	Co-polyester	1.8L	200 x 200 x 510mm

*SUPPLIED WITH 13A PLUG.

EXPEDITOR™ 600R Food Blender Accessories

CODE	DESCRIPTION
6126-HBF600R	Spare 1.8L BPA Free Co-polyester Container
6126-HBF600S	Spare 1.8L Stainless Steel Container



Large Capacity EXPEDITOR™ 1100SR Food Blender



FOOD PREPARATION



TRANSPARENT LID AND DOSING CUP PROVIDES A CLEAR VIEW

HEAVY-DUTY LID LOCKS ENSURE SAFETY

ERGONOMIC COMFORT HANDLES

HIGH, VARIABLE SPEED, CHOP, AND PULSE CHOICES

LIFETIME WARRANTY ON MOTOR DRIVE COUPLING AND STAINLESS STEEL BLADES

PRESET BUTTONS FOR CUSTOM BLENDING AND MEMORY CARD SLOT

LED LIGHTED PRE-SET TIMER PANEL

LOW PROFILE DESIGN WITH TOUCHPAD CONTROL



CHOP



GRIND



BLEND



EMULSIFY



PUREE

- **Low Profile** design for vastly improved operator ergonomics and the ability to easily see into the blender jar during the blend cycle for optimal control of texture and consistency.
- **Variable Speed** that can allow the blender to operate from a low speed (perfect for salad dressings, chopping and grinding) to a high speed that quickly reaches a velvet-smooth puree.

- **Custom pre-set buttons** offer the operator a degree of control. With custom pre-set cycles, recipes can be made consistently time after time and re-programmed by inserting a memory card as the menu changes.
- **Interlock system** designed with kitchen safety in mind. This powerful blender will not start mixing until the jar and lid are securely in place on the blender base.

Large Capacity EXPEDITOR™ 1100SR Food Blender

CODE	MOTOR	CAPACITY	W x D x H
HBF1100SR-UK	3.5 HP	4 L	227 x 378 x 481mm

*SUPPLIED WITH 13A PLUG.

Large Capacity EXPEDITOR™ 1100SR Food Blender Accessories

CODE	DESCRIPTION
6126-1100SR	Spare 4L Stainless Steel Container



Vegetable Processors

BOTH COME COMPLETE WITH FOUR BLADES DF3, DF5, DT3 AND DQ4

FOOD PREPARATION

V-CUT Vegetable Processor

- Fully customise the cut of any fruit or vegetable.
- Slices, cubes, frays, matchsticks, juliennes and micro cube (brunoise) are now easy to make quickly and precisely.
- Using the rotating feed hopper, the new DB discs allow you to cut cubes to a minimum of 4x4mm without ruining the product.
- Practical and wide product feed hopper.
- Product pusher allows a greater load and greater hold of the product.
- Rotation introduction tube for brunoise cutting.
- Removable lid for quick cleaning.
- Stainless steel controls.
- Maximum safety with coded microswitch and control unit on the lid.



new



THE INNOVATIVE DF1-7 ADJUSTABLE DISC ALLOWS YOU TO CUT SLICES OF THICKNESS FROM 1 TO 7MM

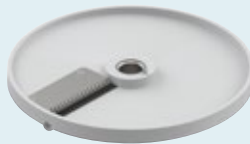

THE DB4 DISC ALLOWS YOU TO CUT MICRO-CUBES AS SMALL AS 4X4MM

V-CUT Vegetable Processor

CODE	POWER	PROD. HR	RPM	W x D x H
V-CUT	0.515kw	220kg	300	280 x 418 x 678mm

TM1 Vegetable Processor

- The TM is a versatile vegetable processor capable of preparing up to 220kg of fresh vegetables, fruit and more per hour.
- Aluminium alloy and stainless steel construction.
- Heavy-duty ventilated motor for continuous operation.
- Thanks to its compact design the machine is easy to install inside every kitchen.
- The exclusive feeding system makes it easy to process also soft products like mozzarella cheese.
- Motor stops when the lever is lifted and the machine does not start if the cover is not in place.
- A large number of discs available for every purpose including specialist slicers, graters, dicers and bacon cutters.



TM1 Vegetable Processor

CODE	POWER	PROD. HR	RPM	W x D x H
TM1	0.515kw	220kg	300	400 x 510 x 710mm

*ALL MODELS SUPPLIED WITH  13A PLUG.

SLICING BLADES



DF2

GRATING BLADES



DTV

JULIENNE BLADES



DQ4

DICING BLADES



PS8/PS8G

ACCESSORIES



Vegetable Processor Blades and Accessories

SLICING BLADES	GRATING BLADES	JULIENNE BLADES	DICING BLADES	ACCESSORIES	V-CUT ONLY
DF2	DTV	DQ4	PS8	TM1 Chute	DB4 Micro-Cube Disc
DF3	DT2	DQ6	PS10	Blade Brush PS8B	DF1-7 Adjustable Disc
DF5	DT3	DQ8	PS14	Blade Brush PS10B	
DF8	DT7	DQ10	PS20	Disc Holder	

C-TRONIC Food Processors



- Ideal for making mayonnaise, sauces, pureeing tomatoes and chopping herbs.
- Sturdy body in die-cast and extruded aluminium.
- Motor and tank side-by-side to prevent heating food.
- Easy to clean, removable stainless steel bowl with handles.
- High efficiency ventilated motor for continuous operation.
- Easy to use controls include micro-switch on lever and safety micro-switch on lid.
- Variable speed control as standard.
- Strong cutlery steel knives.
- See-through Tritan lid with opening to add ingredients during operation.
- Includes spatula and sharpening stones as standard.



REGULAR KNIFE



SERRATED KNIFE



EMULSIFYING KNIFE



PESTO KNIFE



KNEADING KNIFE

C-TRONIC Food Processors

CODE	POWER	RPM	CAPACITY	W x D x H
C-TRONIC 4VT	0.35kw	600 - 2800	3.3L	296 x 457 x 300mm
C-TRONIC 6VT	0.35kw	600 - 2800	5.3L	304 x 457 x 362mm

*ALL MODELS SUPPLIED WITH  13A PLUG.

Accessories

DESCRIPTION	4VT	6VT
Regular knife	MSC04AMON	MSC06AMON
Serrated knife	MSC04AMAZ	MSC06AMAZ
Emulsifying knife	MSC04AMOF	MSC06AMOF
Dough Mix knife	MSC04AMOI	MSC06AMOI
Pesto Sauce knife	MSC04AMOP	MSC06AMOP

Blitz Food Processor



- Equipped with stainless steel standard cutting knife, ABS emulsifying knife and spatula.
- Base unit has thermoresistant ABS construction.
- Polycarbonate lid with feed opening to add ingredients while the cutter is working.
- Lid and bowl interlocked during operation to ensure maximum safety.
- Bowl easily removable for cleaning.

Blitz Food Processor

CODE	POWER	CAPACITY	W X D X H
BLITZ	0.37kw	3.2L	240 x 240 x 355mm

*SUPPLIED WITH  13A PLUG.

Medium Duty Countertop Mixer

- Strong metal case planetary mixer.
- Removable tools for easy cleaning.
- Lifiable head to help remove 7L S/S bowl.
- Includes 3 metal tools.
- D.C. motor with speed control for precise mixing.
- Gear drive and grease lubrication.
- Safety microswitch on the head.
- Suitable for medium density mixing (for example, 1kg of flour).



COMES WITH DOUGH
HOOK, WIRE WHISK,
SPATULA AND 7L
BOWL



Medium Duty Countertop Mixer

CODE	DESCRIPTION	POWER	PLUG	WXDXH
PLUTONE 7	7L Countertop Mixer	0.28kw	13A	410 x 240 x 437mm

Medium Duty Planetary Mixers

- Three-speed settings.
- Lever operated bowl lift.
- Safety stop function.
- Metal wire bowl guard.
- Stainless steel bowl.
- Three metal tools as standard.
- Ventilated gear driven motor.
- Includes whisk, hook and spatula.



COMES WITH DOUGH
HOOK, WIRE WHISK,
SPATULA AND
S/S BOWL



EMERGENCY
STOP BUTTON ON
PLUTONE 20 ES

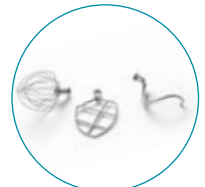

INCLUDED

Medium Duty Planetary Mixers

CODE	DESCRIPTION	PLUG	POWER	W X D X H
A PLUTONE 10	10L Bench-mounted Mixer	13A	0.45kw	440 x 500 x 630mm
PLUTONE 20	20L Bench-mounted Mixer	13A	1.1kw	515 x 560 x 770mm
PLUTONE 20 ES	20L Bench-mounted Mixer with emergency stop	13A	1.1kw	515 x 560 x 770mm
B PLUTONE 30	30L Floor-standing Mixer	13A	1.5kw	630 x 650 x 1160mm
PLUTONE 40	40L Floor-standing Mixer	16A	2.2kw (3PH)	707 x 698 x 1316mm

High Performance Countertop Mixer

- 8L stainless steel bowl.
- Sturdy two handle bowl design is ideal for holding the weight of ingredients while mixing.
- Suitable for medium-duty mixing (for example 2kg of flour).
- Lifiable head makes it easy to add ingredients, scrape sides, change attachments and remove bowl.
- Die-cast aluminium body easily wipes clean.
- Capacitive stop/start buttons easily respond to touch.
- Variable 7-speed dial and pulse function allows for speed changes while mixing.
- All metal gears for long-lasting performance.
- Heavy-duty stainless steel attachments included.



LIFTABLE HEAD

COMES WITH BEATER, DOUGH HOOK, WIRE WHISK WITH SPLASH SHIELD, S/S BOWL AND PLASTIC BOWL GUARD



WARRANTY
2
YEARS
PARTS & LABOUR

FOOD PREPARATION

High Performance Countertop Mixer

CODE	DESCRIPTION	PLUG	POWER	WXDXH
CPM800-UK	8L Countertop Mixer	13A	1.5kw	350 x 430 x 400mm

Heavy Duty Planetary Mixers

- Introducing Vollrath's heavy-duty range of floor, bench and countertop planetary mixers.
- Safety cut-switch automatically turns the unit off if gears are changed without stopping the mixer.
- Emergency stop button.
- All mixers feature a 30-minute timer - mixer automatically stops when timer ends.
- No. 12 hub accommodates Meat Grinder and Vegetable Slicer attachments for flexibility between grinding, slicing, and mixing.
- Comes standard with: Dough hook, Wire whisk, Spatula, Stainless steel mixing bowl, Safety guard.
- Countertop model comes with digital control panel to make easy speed shifts while unit is running.



WARRANTY
2
YEARS
PARTS

WARRANTY
1
YEARS
LABOUR

Heavy Duty Planetary Mixers

CODE	DESCRIPTION	TRANSMISSION	PLUG	POWER	WXDXH
A 4075603	9.5L Countertop Mixer	5 Speed	13A	7/8 HP	332 x 449 x 538mm
B 4075703	19L Bench-mounted Mixer	3 Speed	13A	1/2 HP	518 x 518 x 905mm
C 4075803	28L Floor-standing Mixer	3 Speed	13A	1 HP	635 x 622 x 1216mm
4075903	38L Floor-standing Mixer	3 Speed	13A	1 1/2 HP	673 x 675 x 1197mm

Sirman Slicer Features

FOOD PREPARATION

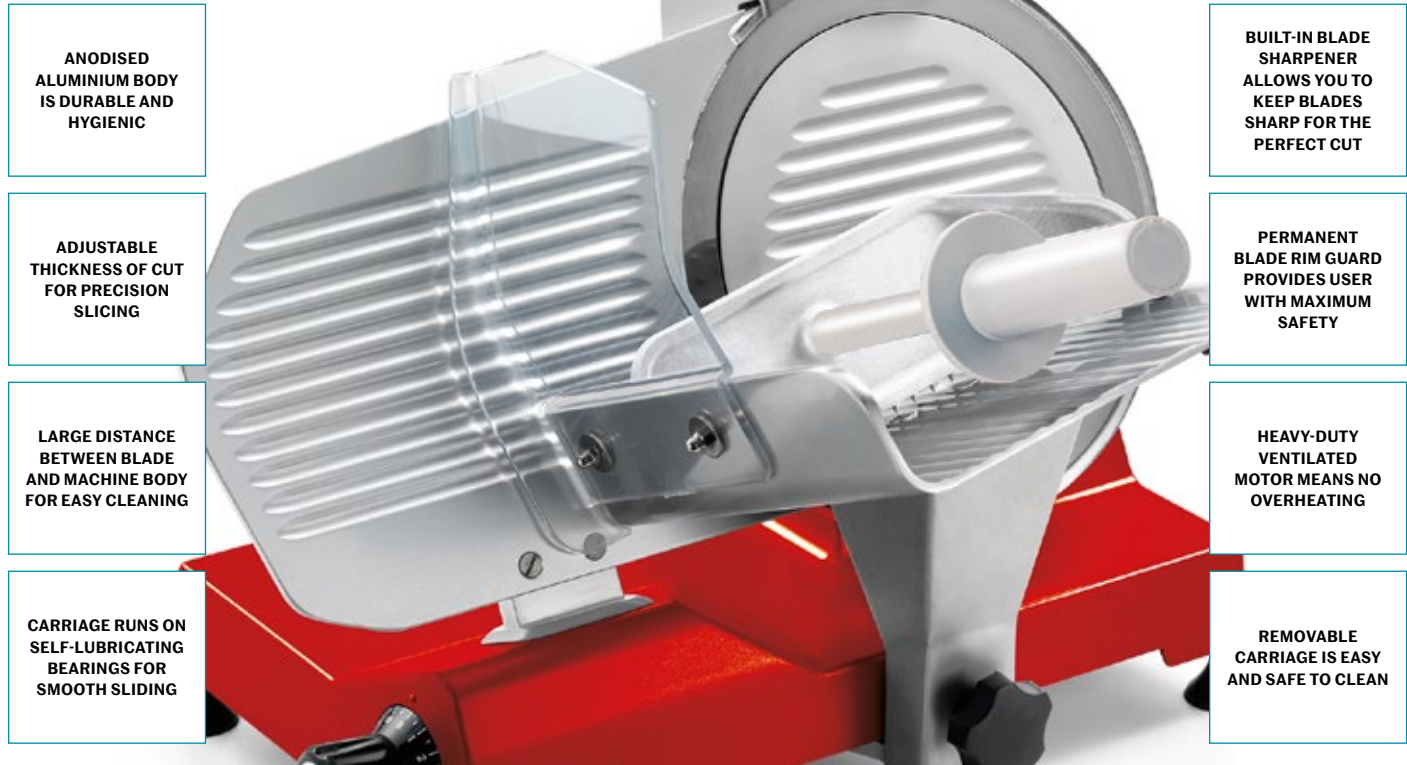

ANODISED ALUMINIUM BODY IS DURABLE AND HYGIENIC

ADJUSTABLE THICKNESS OF CUT FOR PRECISION SLICING

LARGE DISTANCE BETWEEN BLADE AND MACHINE BODY FOR EASY CLEANING

CARRIAGE RUNS ON SELF-LUBRICATING BEARINGS FOR SMOOTH SLIDING

BUILT-IN BLADE SHARPENER ALLOWS YOU TO KEEP BLADES SHARP FOR THE PERFECT CUT

PERMANENT BLADE RIM GUARD PROVIDES USER WITH MAXIMUM SAFETY

HEAVY-DUTY VENTILATED MOTOR MEANS NO OVERHEATING

REMOVABLE CARRIAGE IS EASY AND SAFE TO CLEAN

Smart Entry Level Slicer



- These slicers are ideal for small restaurants, cafes, coffee shops, delis and bars.
- Painted Aluminium Body.

ENTRY LEVEL SLICER IS PERFECT FOR LOW VOLUME SLICING



Smart Entry Level Slicer

CODE	BLADE SIZE	MOTOR	CUT SIZE	W X D X H
SMART 250	250mm 10"	147w/0.20hp	0-13mm	555 x 460 x 460mm
SMART 250 RED	250mm 10"	147w/0.20hp	0-13mm	555 x 460 x 460mm
SMART 250 BLACK	250mm 10"	147w/0.20hp	0-13mm	555 x 460 x 460mm
SMART 300	300mm 12"	147w/0.20hp	0-13mm	570 x 560 x 475mm

*ALL MODELS SUPPLIED WITH  13A PLUG.



Mirra Medium Duty Slicers



RELIABLE
VENTILATED
MOTORS ALLOW
THESE SLICERS TO
RUN NON-STOP FOR
7 HOURS!

- These slicers are ideal for small restaurants, cafes, coffee shops, delis and bars.
- Emergency Stop button for maximum safety.



DEVICE FOR RELEASING THE CARRIAGE

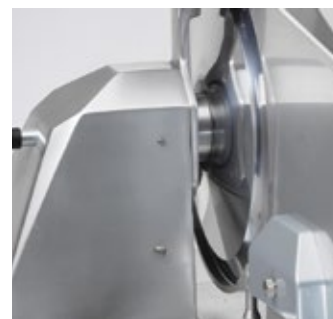

MORE SPACE BETWEEN BLADE AND MOTOR

Mirra Medium Duty Slicers

CODE	BLADE SIZE	MOTOR	CUT SIZE	W x D x H
MIRRA 220	220mm 9"	147w/0.20hp	0 - 13mm	570 x 560 x 475mm
A MIRRA 250	250mm 10"	147w/0.20hp	0 - 13mm	570 x 560 x 475mm
MIRRA 300	300mm 12"	210w/0.29hp	0 - 13mm	640 x 610 x 510mm

*ALL MODELS SUPPLIED WITH  13A PLUG.

Canova & Palladio Heavy Duty Slicers



- These slicers are ideal for restaurants, delis, catering, canteens and butchers.
- Rounded design means no sharp edges and no visible screws.



LARGE CLEARANCE BETWEEN BLADE
AND MACHINE BODY



LARGE HOPPER

Heavy Duty Slicers

CODE	BLADE SIZE	MOTOR	CUT SIZE	W x D x H
B CANOVA 300	300mm 12"	210w/0.29hp	0 - 19mm	640 x 495 x 495mm
C PALLADIO 300	300mm 12"	275w/0.37hp	0 - 23mm	710 x 547 x 545mm
PALLADIO 350	350mm 14"	370w/0.5hp	0 - 23mm	710 x 575 x 530mm

*ALL MODELS SUPPLIED WITH  13A PLUG.

Extra Heavy Duty Slicers

FOOD PREPARATION



Extra Heavy Duty Slicers

CODE	BLADE SIZE	MOTOR	CUT SIZE	W x D x H
A PALLADIO 330 EVO	330mm 13"	275w/0.37hp	0 - 23mm	730 x 630 x 620mm
B RAFFAELLO 350 EVO	350mm 14"	370w/0.5hp	0 - 23mm	840 x 570 x 595mm
C GALILEO 350 EVO	350mm 14"	380w/0.52hp	0 - 25mm	820 x 590 x 700mm

*ALL MODELS SUPPLIED WITH 13A PLUG.

Speciality Slicers

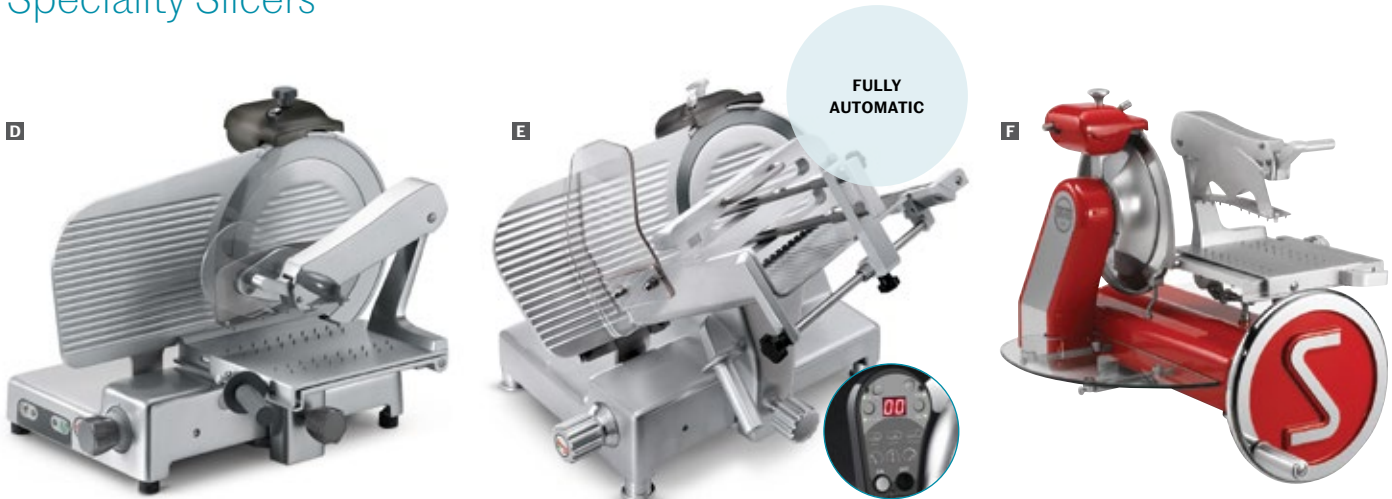

D MANTEGNA 300 BS IS IDEAL FOR SLICING BACON – WITH RAISED GRIPPER SPIKES AND 90° ANGLE

E PALLADIO 300A HAS BOTH ADJUSTABLE SPEED AND CARRIAGE MOVEMENT

F ANNIVERSARIO 300 HAS A STYLISH ITALIAN DESIGN, ROUNDED FOR EASE OF CLEANING

Speciality Slicers

CODE	DESCRIPTION	BLADE SIZE	MOTOR	CUT SIZE	W x D x H
D MANTEGNA 300 BS	Vertical Bacon Slicer	300mm 12"	275w/0.37hp	0–29mm	750 x 600 x 695mm
E PALLADIO 300A	Fully Automatic Slicer	300mm 12"	475w/0.64hp	0–23mm	730 x 660 x 650mm
F ANNIVERSARIO 300	Flywheel Slicer	300mm 12"	–	0 - 3mm	855 x 625 x 590mm

*ALL MODELS SUPPLIED WITH 13A PLUG. ANNIVERSARIO 300 - SUPPLIED WITH NO PLUG OR CABLE

Adjustable Burger Press

- Practical and robust hamburger press with changeable moulds.
- Made of anodised aluminium and stainless steel.
- Self-Centering moulds (Patented system) for perfect coupling of mould with buffer.
- Machine supplied without moulds.
- Automatic hamburger lifting system for easy removal of pieces.

Adjustable Burger Press Supplied without moulds.

CODE	DESCRIPTION	W X D X H
MULTIPATTY	Burger Press	279 x 369 x 404mm

Adjustable Burger Press Moulds

CODE	BURGER SIZE	CODE	BURGER SIZE
MOULD 100	100mm (4")	MOULD 150	150mm (6")
MOULD 130	130mm (5")	MOULD 180	180mm (8")

Burger Presses

- Simple and compact patty press with rounded design.
- Made from anodized aluminium alloy.
- Built-in sheets holder.
- Rubber feet.

Burger Presses Warranty: 1 year parts and labour.

CODE	BURGER SIZE	W X D X H
A SA100	100mm (4")	310 x 270 x 320mm
SA130	130mm (5")	360 x 310 x 360mm
B SA150	150mm (6")	360 x 330 x 380mm

Parmesan Cheese Graters

- These cheese graters are strong as well as compact.
- Simple to operate.
- Grate cheese and bread with uniformity, without any waste.
- Made from polished aluminium, with a galvanised steel drum.
- Suitable for Parmesan cheese only.

Parmesan Cheese Graters

CODE	POWER	RPM	MOUTH DIMS.	W X D X H
C GP	0.38kw/0.5hp	1400	100 x 65mm	290 x 250 x 310mm

Mozzarella Cheese Grater

- Mozzarella grater also suitable for use with soft cheese such as cheddar.
- Made of stainless steel and anodised aluminium.
- Cutlery steel and aluminium grating discs.
- Guard on disc holder opening.
- Disc holder completely removable for cleaning.

Mozzarella Cheese Grater

CODE	POWER	RPM	W X D X H
D ATHOS	0.21kw/0.3hp	400	370 x 230 x 480mm

*ALL CHEESE GRATER MODELS SUPPLIED WITH  13A PLUG.



Pasta Machines

- Designed for medium-duty operations, ideal for small to medium-size restaurants.
- Reliable, user-friendly and easy to clean.
- Stainless steel AISI 304 construction.
- Powerful, air-cooled motor with oil bath gearbox reducer.
- High-performance and easy to remove kneading paddle.
- Interlocked stainless steel lid.
- Convenient removable funnel to add liquid ingredients during processing.
- Stainless steel worm, head and ring.
- Bowl made of anodized aluminium.
- Forced air-cooling system for heavy-duty use.

MACHINE INCLUDES ONE DIE OF YOUR CHOICE

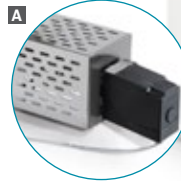

OPTIONAL VARIABLE-SPEED PASTA CUTTER



LARGER MODELS AVAILABLE
PLEASE CONTACT OUR OFFICE FOR MORE INFORMATION

Pasta Machines

CODE	POWER	BOWL CAPACITY	DOUGH CAPACITY	OUTPUT	W X D X H
SINFONIA 2	0.5 HP	6L	2.5kg	5kg/hr	577 x 263 x 489mm
CONCERTO 5	1 HP	10L	4kg	8.4kg/hr	665 x 305 x 630mm

*ALL MODELS SUPPLIED WITH  13A PLUG.

SINFONIA Accessories

A 40116150	Pasta Cutter
28184000	Adjustable Sheeter
B 28184009	Spaghetti Die (1.9mm)
C 28184021	Linguine Die (3x1.6mm)
D 28184034	Tagliatelle Die (6mm)
E 28184077	Macaroni Die (8mm)
F 28184240	Fusilli Die (8.4mm)

CONCERTO Accessories

A 40115150	Pasta Cutter
28181000	Adjustable Sheeter
B 28180009	Spaghetti Die (1.9mm)
C 28180021	Linguine Die (3x1.6mm)
D 28180034	Tagliatelle Die (6mm)
E 28180077	Macaroni Die (8mm)
F 28180240	Fusilli Die (8.4mm)

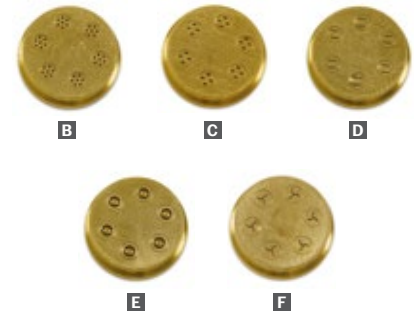

Pasta Sheeters

- Powerful dough roller.
- Vertical construction reduces countertop space and facilitates gripping of the dough at outfeed.
- Stainless steel construction.
- Ventilated motor in non-stop operating mode with dual reduction.
- Coaxial reduction gear belt transmission.
- Adjustable dough thickness 0-1.0mm.
- Infeed area protected with safety Microswitch.
- Wide chute for dough infeed.
- Application of optional cutter available in 2, 6, 8 and 12mm.

Pasta Sheeters

CODE	POWER	ROLLER DIMENSIONS	W X D X H
SANSONE 25	0.5 HP	Ø60 x 250mm	515 x 322 x 450mm
SANSONE 32*	0.5 HP	Ø60 x 350mm	600 x 322 x 450mm

*ALL MODELS SUPPLIED WITH  13A PLUG. SANSONE 32 ALSO AVAILABLE IN 3 PHASE UPON REQUEST



Dough Mixers

- Made from large thickness C40 steel.
- Scratch-resistant powder coating.
- Bowl with reinforced edge and AISI 304 S/S shaft.
- Forged spiral tool.
- Lid with opening to add ingredients during operation.
- High efficiency ventilated motor with oil-bath gearbox.
- Reinforced chain drive.
- Low voltage IP67 protection rated controls.
- 2 speed models with timer available.
- Wheels as standard.

Dough Mixers

CODE	CAPACITY	POWER	W X D X H
HERCULES 10	12L / 8kg	0.37kw	305 x 580 x 560mm
HERCULES 20	21L / 17kg	0.75kw	390 x 680 x 705mm
HERCULES 30	32L / 25kg	1.1kw	440 x 740 x 780mm
HERCULES 40	41L / 35kg	1.5kw	480 x 825 x 810mm
HERCULES 50	52L / 44kg	1.5kw	540 x 880 x 830mm

2 Speed Dough Mixers

2 SPEED CODE
-
HERCULES 20 2V
HERCULES 30 2V
HERCULES 40 2V
HERCULES 50 2V

*ALL MODELS SUPPLIED WITH  13A PLUG. ALSO AVAILABLE IN 3 PHASE UPON REQUEST

Liftable Head Dough Mixers

- Liftable head for tank removal and easy cleaning.
- Removable container.
- Made from large thickness C40 steel.
- Scratch-resistant powder coating.
- Bowl with reinforced edge and AISI 304 S/S shaft.
- Forged spiral tool.
- Lid with opening to add ingredients during operation.
- High efficiency ventilated motor with oil-bath gearbox.
- Reinforced chain drive.
- Low voltage IP67 protection rated controls.
- 2 speed models with timer available.
- Wheels as standard.

Liftable Head Dough Mixers

CODE	CAPACITY	POWER	W X D X H
HERCULES 20 TA	21L / 17kg	0.75kw	400 x 751 x 715mm
HERCULES 30 TA	32L / 25kg	1.1kw	440 x 823 x 790mm
HERCULES 40 TA	41L / 35kg	1.5kw	490 x 910 x 820mm
HERCULES 50 TA	52L / 44kg	1.5kw	540 x 970 x 875mm

2 Speed Liftable Head Dough Mixers

2 SPEED CODE
HERCULES 20TA 2V
HERCULES 30TA 2V
HERCULES 40TA 2V
HERCULES 50TA 2V

*ALL MODELS SUPPLIED WITH  13A PLUG. ALSO AVAILABLE IN 3 PHASE UPON REQUEST

Pizza Dough Rollers

- Practical and easy-to-use pizza roller, ideal for rolling out circles of dough to prepare pizza, focaccia, bread, etc.
- Operates without heat to avoid altering the properties of the dough.
- The thickness and diameter of the rolled out circles can be easily adjusted based on the user's needs.
- Made of strong AISI 430 stainless steel perfect for commercial kitchens.
- Slide and roller scraper are easily removable for cleaning.
- IP 67 controls with NVR.

Pizza Dough Rollers

CODE	ROLLER	ROLLER DIMENSIONS	POWER	W X D X H
P-ROLL 320/1	Single	320mm	0.24kw	470 x 460 x 390mm
A P-ROLL 420/1	Single	420mm	0.24kw	610 x 460 x 390mm
P-ROLL 320/2	Double	220/320mm	0.24kw	470 x 460 x 715mm
B P-ROLL 420/2	Double	220/420mm	0.24kw	570 x 460 x 800mm

*ALL MODELS SUPPLIED WITH  13A PLUG.



Medium Duty Meat Mincers

- Innovative design, compact and functional machine.
- Easy to carry thanks to its side handles.
- Anodised aluminium body and ABS shockproof sides.
- Ventilated motor has a reverse switch which enables the user to free any meat without dismantling the cutting group.
- Compartment for knives and plates.



Medium Duty Meat Mincers

CODE	POWER	OUTPUT	PLATE	W X D X H
TC8 Vegas	0.25kw/0.34hp	70kg/hr	6mm	335 x 300 x 410mm
TC12 Denver	0.55kw/0.75hp	85kg/hr	6mm	377 x 366 x 452mm
TC22 Dakota	0.75kw/1hp	120kg/hr	4.5mm	395 x 360 x 485mm

*ALL MODELS SUPPLIED WITH  13A PLUG. ALSO AVAILABLE IN 3 PHASE UPON REQUEST

Heavy Duty Meat Mincers

- AISI 304 stainless steel construction.
- Powerful IP 55 insulated and fan-cooled motors for continuous use.
- Motor-reducer equipped with a double seal for long, trouble-free service.
- Convenient head interlock mechanism.
- Stainless steel mincing head carefully designed for high yield production.
- Feed tray designed with safety interlock and square neck for outstanding performance.
- IP 54 protected, 24 V controls.



Heavy Duty Meat Mincers

CODE	POWER	OUTPUT	PLATE	W X D X H
TC22 Colorado	1.47kw/2hp	300kg/hr	4.5mm	500 x 437 x 490mm
TC32 Colorado	2.2kw/3hp	400kg/hr	6mm	610 x 465 x 530mm

*ALL MODELS SUPPLIED WITH  13A PLUG. ALSO AVAILABLE IN 3 PHASE UPON REQUEST

Extra Heavy Duty Meat Mincers

- Up to 650kg per hour output.
- AISI 304 stainless steel construction.
- Powerful IP 55 insulated and fan-cooled motors for continuous use.
- Endless screw motor-reducer running in an oil-bath enables a long service life.
- Motor-reducer equipped with a double seal for long, trouble-free service.
- Stainless steel mincing head carefully designed for high yield production.
- Feed tray designed with safety interlock square neck for outstanding performance.

REFRIGERATED
MODELS ALSO
AVAILABLE



Extra Heavy Duty Meat Mincers

CODE	POWER	OUTPUT	PLATE	W X D X H
TC22 Nevada	1.47kw/2hp	350kg/hr	4.5mm	512 x 390 x 531mm
TC32 Nevada	2.2kw/3hp	650kg/hr	4.5mm	637 x 455 x 551mm

*ALL MODELS SUPPLIED WITH  13A PLUG. ALSO AVAILABLE IN 3 PHASE UPON REQUEST

PrimaVac™ Chamber Vacuum Packers

PrimaVac™ gives commercial kitchens the flexibility they need for a wide range of tasks, from retaining food's freshness and colour to giving chefs the ability to easily store, preserve marinate, or sous vide a variety of dishes.



ADJUSTABLE SOFT AIR GRADUALLY ADDS AIR TO CHAMBER TO HELP PROTECT DELICATE FOOD



DURABLE STAINLESS STEEL HOUSING WITHSTANDS THE DEMANDS OF A COMMERCIAL KITCHEN

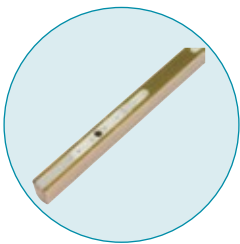

REMOVABLE HEAT SEAL BAR FOR EASY CLEANING AND FOOD SAFETY



GAS FLUSH (HVC406-UK) CREATES A PROTECTIVE CUSHION INSIDE POUCHES TO PROLONG FOOD'S SHELF LIFE AND FRESH COLOUR

PRIMAVAC™ POUCHES AVAILABLE VISIT FEM.CO.UK



A



B

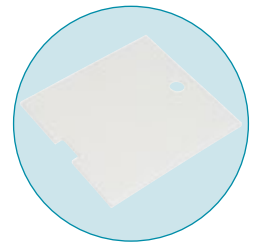

REMOVABLE FILLER PLATE AND CLEAR LID



10 CUSTOM PROGRAMMES ALLOW YOU TO SET THE PERFECT VACUUM AND SEALING TIMES FOR DIFFERENT APPLICATIONS



JETAIRE™ VACUUM SEALING PUMP EXTRACTS 99% OF THE AIR FROM POUCHES ENSURING BEST RESULTS



INCLUDES MAINTENANCE KIT TO KEEP EQUIPMENT PERFORMANCE OPTIMISED

PrimaVac™ Chamber Vacuum Packers

CODE	POWER	SEALING BAR	W X D X H
HVC254-UK	0.25kw	254mm	337 x 456 x 377mm
A HVC305-UK	0.35kw	305mm	379 x 491 x 373mm
B HVC406-UK	0.85kw	406mm	494 x 616 x 486mm

*ALL MODELS SUPPLIED WITH  13A PLUG.



Sirman Vacuum Packaging Machines

In-Chamber Vacuum Packers

- Compact and fast machine.
- Ideally combined with low-temperature cooking instruments like the Softcooker.
- Easily settable vacuum and sealing time.
- Easily removable sealing bar.
- Busch suction pump.
- Display of vacuum percentage and time to countdown.
- Last setting can be saved in memory.
- Rev counter and pump meter.
- Pump preheating and oil cleaning cycle.
- Change oil message.
- Timed external vacuum.
- Manual cover lift.
- Plastified steel vacuum chamber.



In-Chamber Vacuum Packers

CODE	POWER	SEALING BAR	W X D X H
EASYVAC 25	0.10kw	260mm	338 x 565 x 257 (708)mm
EASYVAC 30	0.10kw	310mm	406 x 656 x 315 (731)mm
EASYVAC 40	0.35kw	410mm	494 x 637 x 315 (810)mm

*ALL MODELS SUPPLIED WITH 13A PLUG.



Vacuum Packers with Domed Lid

- Exclusively designed with simple-to-use controls and a reduced workspace.
- Busch vacuum pump.
- 5mm thick, AISI 304 stainless steel, easy to clean plain vacuum chamber.
- Thick transparent plexiglass lid for viewing the process from start to finish.
- Removable sealing bar.
- Complete electronic control system.
- Gas system and soft air release system are optional.
- EASY models have simplified control board.



Vacuum Packers with Domed Lid

CODE	POWER	SEALING BAR	W X D X H
W8 30 EASY	0.35kw	310mm	402 x 525 x 587mm
W8 40 EASY	0.75kw	410mm	493 x 585 x 630mm

*ALL MODELS SUPPLIED WITH 13A PLUG.



Vacuum Packers with Wi-Fi

- Extraordinary design which reduces the footprint of the machine and improves comfort.
- Easily removable sealing bar with automatic lifting lid.
- Easy to clean thanks to the perfect flatness of the support product plan.
- 5mm thick, AISI 304 stainless steel, easy to clean plain vacuum packer.
- Electronic control system with pressure sensor for fast and precise processing.
- Adjustable automatic vacuum percentage settings.
- Dedicated programmes for liquids and marinating.
- Scheduled management of maintenance operations to ensure longer-lasting life.
- Built-in Wi-Fi card which allows careful management of after-sales service at a distance.
- 3-year pump warranty (for machines connected via Wi-Fi).

BUILT-IN WI-FI WITH PRACTICAL AND INTUITIVE TOUCH SCREEN DISPLAY



Vacuum Packers with Wi-Fi

CODE	POWER	SEALING BAR	W X D X H
W8 TOP 30	0.35kw	310mm	402 x 525 x 587mm
W8 TOP 40	0.75kw	410mm	493 x 585 x 630mm
W8 TOP 50	0.75kw	510mm	609 x 640 x 605mm

*ALL MODELS SUPPLIED WITH 13A PLUG.

External Vacuum Packers

A compact vertical vacuum packaging machine ideal for liquids, granulates and powders. Perfect for use in bars or as a second machine.

- Maximum bag size of 300 x 350mm which can hold 3L.
- Easy Touch controls.
- Practical niches on the profile to move the unit.
- Transparent sides of the tank offer perfect visibility inside the tank.
- Side panels can be easily and completely disassembled without tools for easy and thorough cleaning inside the tank.

External Vacuum Packers

CODE	POWER	SEALING BAR	W X D X H
W8 VERTIGO 30	0.15kw	310mm	396 x 416 x 300mm

*ALL MODELS SUPPLIED WITH 13A PLUG.

External Vacuum Packers

- The ideal machine for container vacuum packing.
- Compact and user friendly.
- Bush suction pump as standard.
- Easy vacuum time setting.
- Oil preheat and cleaning cycle.
- Oil and filter change message.
- Hose filter to avoid suction of solid parts.
- GN containers and lids sold separately.



External Vacuum Packers

CODE	POWER	SEALING BAR	W X D X H
VACUEX 4	0.1kw	mc/h 4	488 x 232 x 343mm
VACUEX 8	0.35kw	mc/h 8	488 x 232 x 343mm

*ALL MODELS SUPPLIED WITH 13A PLUG.

Gastronorm Containers

CODE	DESCRIPTION
5858VAC11100B	GN 1/1 100mm
5858VAC11150B	GN 1/1 150mm
5858VAC12100B	GN 1/2 100mm
5858VAC12150B	GN 1/2 150mm
5858VAC13100B	GN 1/3 100mm
5858VAC13150B	GN 1/3 150mm

Gastronorm Lids

CODE	DESCRIP.
5858VAC11000C	GN 1/1
5858VAC12000C	GN 1/2
5858VAC13000C	GN 1/3

Bag Sealers

- Fast and easy to use.
- Can seal all types of plastic bags for food.
- The timer fitted at the front is used to seal bags of different thicknesses.

Bag Sealers

CODE	DESCRIPTION	POWER	SEAL LENGTH	W X D X H
S300	-	510w	300mm	455 x 75 x 260mm
A S400	-	700w	400mm	555 x 75 x 260mm
S400-2T	With Cutter	700w	400mm	555 x 75 x 260mm



A

Shrink Wrapper

- Designed for packing meat, cheese, pasta, fruits and vegetables.
- These wrapping machines offer a quick and safe daily packaging method.
- Anodized aluminium rollers and rods.
- Heating surface temperature adjustable by thermostat (45K version).
- 45K version has a Teflon coated section (do not smoke).

Shrink Wrapper

CODE	POWER	MAX FILM ROLL	W X D X H
B 45K	0.12kw	450mm	485 x 600 x 140mm



B

Tray Thermosealer

- Practical and robust manual tray sealer.
- 304 Stainless Steel body.
- Electronic controller with temperature and preheating controls.
- Tray count and 4 seconds sealing time.
- Teflon coated aluminium sealing plate.

SIGIX TO BE ORDERED WITH TRAY FRAME
4 FRAME OPTIONS TO CHOOSE FROM
VISIT FEM.CO.UK
*TRAY FRAME INCLUDED WITH UNIT PRICE

Tray Thermosealer

CODE	POWER	MAX FILM ROLL	MAX. TRAY	W X D X H
C SIGIX	0.9kw	200mm	260 x 190mm	257 x 525 x 496mm



C

UV Steriliser Cabinets

- Easily holds glasses, cutlery and accessories with no need to turn them for perfect bacteria and virus sterilisation.
- A safety microswitch switches the lamps on when the door is opened and switches them off when it is closed.
- Mercury vapour lamp UV with wire screen protection.
- Made from AISI430 stainless steel.
- Removable internal holder and drip tray.
- For courtesy lamp on model 24W, machine must be "on" and timer set to "o".
- UV 16W L supplied with lock.

UV Steriliser Cabinets

CODE	UV LIGHT	TIMER	POWER	W X D X H
D UV 16W	1 x 16w	0-120 mins	70w	400 x 140 x 620mm
UV 16W L	1 x 16w	0-120 mins	70w	400 x 140 x 620mm
E STER UVC 24W S	3 x 8w	0-120 mins	100w	400 x 300 x 620mm



E

D

*ALL MODELS SUPPLIED WITH  13A PLUG

Smart Kitchen Timers



Improve efficiency, quality and consistency while saving money by reducing waste, employee training time and operating costs. With the Smart Kitchen Timer, you can rest easy knowing that your kitchen is always operating at peak performance.

- Features a glove safe, 6.8" touchscreen display which utilises 'tiles' instead of traditional product channels.
- Users can programme an unlimited number of tiles, each containing a unique icon, description, timer, duty cycle and action message.
- Programme and make changes wirelessly through the powerful configuration tool.
- Programme up to 200 job aids such as build cards, operation instructions and cleaning instructions for employees.
- Numerous probe and sensor options available for temperature, humidity, current and level monitoring.
- Fully encapsulated control board for protection against heat, humidity and grease.
- Easy mounting in any location with either horizontal or vertical screen orientations.



MULTIPLE LAYOUTS TO CHOOSE FROM



Smart Kitchen Timers

CODE	PROGRAMMING	NO. OF TIMERS	W X D X H
A T-2268	USB	Up To 96	197 x 35 x 88mm
H-2268	USB / Wireless	Up To 1000	197 x 35 x 88mm

*ALL MODELS SUPPLIED WITH 13A PLUG.

Multi-Function Kitchen Timers



Prince Castle timers are Built to Last!

Restaurant owners and kitchen staff rely on durable, precise, and easy-to-use timers for fast-paced kitchens. Prince Castle multi-function timers feature independently programmable channels for managing multiple tasks at once, plus a USB port for quick menu updates and an illuminated LED that highlights the next function to finish, keeping kitchens efficient and organised.

- Multi-functional - Helps manage multiple menu items cooking at the same time.
- Quick Setup - Fast and simple programming with the new QuickSet software.
- USB Port - Easily program, distribute menu updates and recipe changes, streamlining the process and keeping your kitchen up-to-date effortlessly.
- Switch Guard Protection - Prevent accidental shut-offs. This innovative feature adds an extra layer of security and peace of mind, providing uninterrupted functionality.
- Durability - Engineered with durable components, no glass, to withstand the tough conditions of a kitchen environment.
- Easy to Mount - Replaceable cord and adjustable mounting bracket.
- LED Channel Indicators - Multi-coloured LED channel indicators display the status of the timing cycle and provide an early warning as the countdown expires.
- Detachable power cord for easy replacement, extending the life of your timer.

Multi-Function Kitchen Timers

CODE	DESCRIPTION	W X D X H
B PCT04	4-Channel Single/Multi-Function Timer	159 x 64 x 124mm
PCT08	8-Channel Single/Multi-Function Timer	220 x 64 x 124mm
C PCT12	12-Channel Single/Multi-Function Timer	284 x 64 x 124mm
PCT04V	4-Channel Vertical Multi-Display - Single/Multi-Function Timer	124 x 64 x 159mm
D PCT08V	8-Channel Vertical Multi-Display - Single/Multi-Function Time	124 x 64 x 259mm

*ALL MODELS SUPPLIED WITH 13A PLUG.



FOOD PREPARATION

Manual Food Preparation

Saber King

Saber King

- Save time and labour by slicing multiple pieces at once.
- Multi-purpose chassis with easily interchangeable blade sets.
- Efficient and simple to use.
- Save space by slicing tomatoes, lettuce and onions on the same slicer.
- Improve safety with patented blade covers.
- Easily cleaned blade cartridge improves safety and efficiency.
- Patented system allows for easier food preparation and clean-up.

CODE	DESCRIPTION	W X D X H
A 980-000-00	Saber King Chassis	416 x 416 x 584mm
B 981-000-00	Saber King Mini Chassis	381 x 533 x 584mm

Saber King Accessories

CODE	BLADE
C 980-000-12A	Tomato Blade Set (6.35mm)
D 980-000-20A	Onion Blade Set (4.8mm)
E 980-000-33A	Lettuce Blade Set (25.4 x 50.8mm)

Saber King Mini Accessories

CODE	BLADE
F 981-000-12A	Tomato Blade Set (6.32mm)
G 981-000-20A	Universal Blade Set (4.8mm)
H 981-000-61A	6 Wedge Blade Set



Tomato Saber

Tomato Saber

- Perma-Tight blade cartridge system never needs adjusted.
- Perfect slicing everytime with built-in hand guard.
- Ergonomically-designed contoured pusher handle carries tomato through blades instead of rolling it.
- Tomato Catcher reduces clean-up and improves food safety.

CODE	SLICE THICKNESS	W X D X H
943-B	6.4mm	465 x 216 x 237mm

Accessories

CODE	DESCRIPTION
943-039A	Blade Cartridge
953	Tomato Core-It



TOMATO CORE-IT

Bagel Saber

Bagel Saber Designed to deliver a perfectly sliced bagel in one-quick action. Simple to operate, saving time and money.

CODE	SLICE THICKNESS	W X D X H
970-A	50.8mm	210 x 305 x 133mm



Multi-Purpose Cutter

A InstaCut™ 5.1 With pop-in, pop-out blade accessories to dice, slice, wedge and core 3x faster than by hand. Comes with 6.4mm Dice blade as standard. Other blades available on request.

55457	InstaCut 5.1
-------	--------------

Potato Chipper

B Potato Cutters

Heavy-duty nickel-plated cast iron frame and handle. Screw holes for table mounting.

47713	French Fry (10mm ² cut)
-------	------------------------------------

47714	French Fry (11mm ² cut)
-------	------------------------------------

Dicer

C Dice Witch® Dices onions and other firm vegetables with one stroke. Fast and easy to use. Dice cube measures approximately 9.5mm. Dice Witch® includes tongs. Replacement blade set available.

910-A	Dice Witch®
-------	-------------

910-50	Blade Set
--------	-----------

Wedgers

D Wedge Witch® Sections fruit and vegetables in perfect portions. Easy to clean and use. 8-section wedger constructed of heavy-duty aluminium.

908-A8	Wedge Witch®
--------	--------------

925-059S	Blade Set
----------	-----------

E Citrus Saber® Sections fruit and vegetables in perfect portions. Easy to clean and use. 8-section wedger constructed of high impact plastic. Replacement blade set available.

CW-6	Citrus Saber®
------	---------------

925-059S	Blade Set
----------	-----------

Cheese Prep

F Redco® CubeKing™ Produces uniform cheese cubes, sticks, square blocks, and rectangular blocks in record time. Interchangeable slicing arm cuts include Mozzarella, Cheddar and Swiss cheese.

F 1812	CubeKing™ 9.5mm Cut
--------	---------------------

1811	CubeKing™ 19mm Cut
------	--------------------



Featured Brands



Drinks & Dessert Preparation

Drinks can make a meal, or become one. From nutrient-packed green juices and smoothies to creative shakes, cocktails, and mocktails, there's a world of flavour to explore. Our versatile range of blenders, mixers, crushers, and juicers are built to handle it all, delivering consistent performance every time. Designed to last, these powerful drink and dessert preparation machines keep your service flowing as smoothly as the drinks themselves.

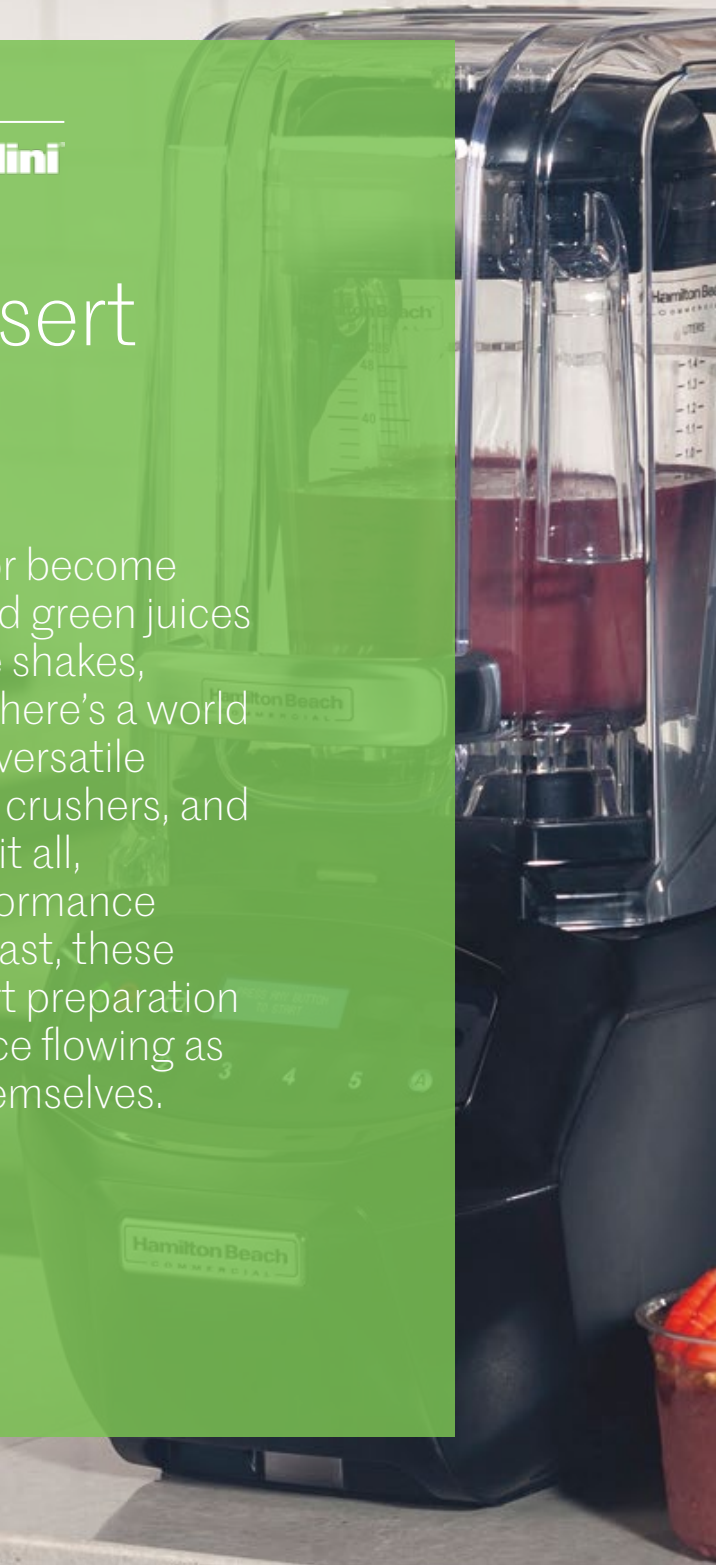



Blender Guide	32
Bar Blenders	33
High Performance Blenders	34
Container Rinser & Station	38
Drink Mixers	38
Hot Drink Dispensers	40
Ice Cream Machines	40
Frozen Drink Machines	41
Chilled Drink Machines	42
Ice Crushers	43
Citrus Juicers	44

Which Blender Is Right For You?

908®R Bar Basics

- Uses crushed ice
- 1HP and 2 Speeds



PAGE
33

Rio® Smooth Results with Wave-Action

- Uses crushed ice
- 1.6HP with pulse



PAGE
33

Tango® Set the Time & Walk Away

- Uses full cube ice
- 2.4HP with timer



PAGE
34

Fury® Powerful Precision Blending

- Uses full cube ice
- 3HP with Timer



PAGE
34

Tempest® Powerful Workhorse

- Uses full cube ice
- 3HP with Jump Cycle



PAGE
35

Eclipse® Quiet & Customised

- Uses full cube ice
- 3HP with versatile programming



PAGE
36

Summit® Edge More Power & Faster Quieter Blending

- Uses full cube ice
- 3.5HP with Auto-Blend and PowerBlend Technology



PAGE
37

MixStation™ Drinks Mixer Heavy-duty Mixing

- For soft ice cream and mix-ins
- 3/4HP with Slow Start Function



PAGE
38

go8®R Blender



SUITABLE FOR FROZEN DRINKS

NEW DESIGN!



LID OPEN SENSOR PREVENTS BLENDING IF LID IS REMOVED



DURABLE TOGGLE SWITCH IS EASY TO REACH AND CONTROL

- Two speed option enables versatility and precision blending for a wide variety of food and drink mixtures.
- Powerful 1 HP motor lets user blend ingredients quickly and optimises blending consistency.
- Wave-Action® System continually forces mixture down into the blades for smooth results.
- Durable stainless steel blades quickly cut through ice and other ingredients.
- SureGrip™ feet hold blender securely in place.
- Uses crushed ice.



go8®R Blender Durable entry level blender. Stackable Polycarbonate container included.

CODE	MOTOR	CONTAINER	CAPACITY	W x D x H
HBB908R-UK	1 HP	Polycarbonate	1.25L	205 x 195 x 400mm

*SUPPLIED WITH  13A PLUG.

go8®R Accessories

CODE	DESCRIPTION
6126-908R-CE	Spare 1.25L Polycarbonate Container
6126-908S-CE	Spare 0.95L Stainless Steel Container

Rio® Blenders



SUITABLE FOR FROZEN DRINKS

NEW DESIGN!

- Wave-Action® System continually forces mixture down into the blades for smooth results.
- Two speeds with pulse option offers versatility and precision blending for a wide variety of food and drink mixtures.
- Durable stainless steel blade design quickly cuts through ice and other ingredients.
- Lid open and jar pad sensor prevents blending if jar or lid is not on correctly for an added layer of safety.
- Sealed paddle switches are water resistant and easy to use while a protective brow directs drips away from controls.
- Triple-Seal lid.
- SureGrip™ feet hold blender securely in place.
- Uses crushed ice.



Rio® Blender Durable, hardworking blender with a pulse action. Stackable Co-polyester or Stainless Steel container included.

CODE	MOTOR	CONTAINER	CAPACITY	W x D x H
HBB255-UK	1.6 HP	Co-polyester	1.4L	190 x 216 x 410mm
HBB255S-UK	1.6 HP	Stainless Steel	0.95L	190 x 216 x 430mm

*ALL MODELS SUPPLIED WITH  13A PLUG.

Rio® Accessories

CODE	DESCRIPTION
6126-455-CE	Spare 1.4L BPA-Free Co-polyester Container
6126-255S-CE	Spare 0.95L Stainless Steel Container

Tango® Blender



SUITABLE FOR FROZEN DRINKS & SMOOTHIES

NEW DESIGN!



LID OPEN SENSOR PREVENTS BLENDING IF LID IS REMOVED



PROTECTIVE BROW DIRECTS DRIPS AWAY FROM CONTROLS

- Wave-Action system continually forces mixture down into the blades for smooth results.
- Timer automatically turns blender off after a preset time giving you the time to get other work done.
- Adjustable timer: 0-40 seconds and continuous run for walkaway convenience.
- Jar pad sensor helps prevent 'wear and tear' by turning off the motor when the container is not properly in place.
- Durable and easy-to-use sealed switches ensure long life.
- Triple-seal lid.
- All-metal drive coupling offers long-lasting performance.
- Four stainless steel cutting and mixing blades quickly cut through ice and other ingredients.
- SureGrip™ feet hold blender securely in place.
- Uses full cube ice.



Tango® Blender Ideal for preparing iced drinks, cocktails and smoothies. Stackable Co-polyester container included.

CODE	MOTOR	CONTAINER	CAPACITY	W x D x H
HBH455-UK	2.4 HP	Co-polyester	1.4L	205 x 195 x 400mm

*SUPPLIED WITH 13A PLUG.

Tango® Accessories

CODE	DESCRIPTION
6126-455-CE	Spare 1.4L BPA-Free Co-polyester Container

Fury® Blender



SUITABLE FOR FROZEN DRINKS SMOOTHIES ICED COFFEE ICE CREAM

NEW DESIGN!



PRECISION BLENDING WITH INTUITIVE CONTROLS



- Powerful performance with 3 peak* HP motor.
- Super-smooth drink profile with patented Wave-Action® system.
- Precision blending with intuitive controls.
- Adjustable timer with automatic shutoff frees up operators for other tasks.
- Stackable 64 oz. / 1.8 L BPA-free co-polyester container frees up counter space and has laser-etched measurement marks that last a lifetime.
- Extremely durable all-metal drive coupling with jar pad sensor.
- Large paddle switches with 2- speeds and pulse button enable fast and easy operation.
- Sure Grip™ feet prevent skidding.
- Uses full cube ice.
- Lifetime warranty on blade and motor drive coupling.



Fury® Blender

CODE	MOTOR	CONTAINER	CAPACITY	W x D x H
HBH550R-UK	3 HP	Co-polyester	1.8L	200 x 200 x 470mm

*SUPPLIED WITH 13A PLUG.

Fury® Accessories

CODE	DESCRIPTION
6126-650R	Spare 1.8L BPA-Free Co-polyester Container
98650R	Fury® Blender Repair Kit

Carefully engineered and built to last, the Tempest® High-Performance Blender by Hamilton Beach Commercial® satisfies the fast-paced blending demands!

LIFETIME WARRANTY
BLADE & MOTOR DRIVE COUPLING

BACK TO BASE WARRANTY
3 YEARS
PARTS & LABOUR

DRINKS & DESSERT PREPARATION



UNIQUE WAVE-ACTION SYSTEM CONTINUALLY FORCES MIXTURE DOWN TO THE BLADES FOR SUPER-SMOOTH RESULTS



USES FULL CUBE ICE



TIMER AUTOMATICALLY TURNS BLENDER OFF AFTER PRESET TIME FREEING UP STAFF FOR OTHER TASKS



STACKABLE CONTAINER FREES UP COUNTER SPACE WITH LASER-ETCHED MEASUREMENTS



TWO SPEEDS, JUMP CYCLE & PULSE OFFER PRECISION BLENDING FOR VARIOUS APPLICATIONS



NEW DESIGN!

BLINKING RED LIGHT INDICATES WHEN CONTAINER IS NOT IN PLACE

SUITABLE FOR FROZEN DRINKS
SMOOTHIES
ICED COFFEE
ICE CREAM



TEMPERATURE GAUGE ALERTS STAFF IF MOTOR OVERHEATS TO PREVENT BURNOUT WITH COOLDOWN FEATURE

Tempest® Blender

Tempest® Blender Designed for high volume operators who need fast, powerful, high-density blending performance. Stackable co-polyester container included.

CODE	MOTOR	CAPACITY	W x D x H
HBH650R-UK	3 HP	1.8L	209 x 205 x 470mm

*SUPPLIED WITH 13A PLUG.

Tempest® Accessories

CODE	DESCRIPTION
6126-650R	Spare 1.8L BPA-Free Co-polyester Container
98650R	Tempest®R Blender Repair Kit





EASILY CONVERTS FOR IN-COUNTER USE



UNIQUE WAVE-ACTION SYSTEM CONTINUALLY FORCES MIXTURE DOWN TO THE BLADES FOR SUPER-SMOOTH RESULTS



QUIETBLEND™ TECHNOLOGY AND ADVANCED QUIET SHIELD™ ENCLOSURE REDUCES BLENDER VOLUME



OPTIONAL FROTHING JAR TO FROTH MILK, WHIP HEAVY CREAM AND EMULSIFY SAUCES

USES FULL CUBE ICE



SUITABLE FOR FROZEN DRINKS SMOOTHIES ICED COFFEE ICE CREAM

NEW DESIGN!



CONVENIENT CLIPS ALLOW FOR EASY REMOVAL OF QUIET SHIELD™ FOR CLEAN-UP



SEALED LID PREVENTS LEAKS WITH EASY-TO-LIFT TAB AND REMOVABLE FILLER CAP



MEMORY CARD SLOT FOR CUSTOM PROGRAMMING, IDEAL FOR MULTI-SITE OPERATIONS OR CHAINS

LIFETIME WARRANTY
BLADE & MOTOR DRIVE COUPLING

BACK TO BASE WARRANTY
3 YEARS
PARTS & LABOUR



ONE-TOUCH BLENDING FUNCTIONS WITH OVER 100 PRE-PROGRAMMED CYCLES

Eclipse® Blender

Eclipse® Blender Quick and powerful blender. Includes stackable 2L co-polyester container and QuietShield™ enclosure.

CODE	MOTOR	CAPACITY	W x D x H
HBH755R-UK	3 HP	2L	220 x 290 x 470mm

*SUPPLIED WITH 13A PLUG.



Eclipse® Accessories

CODE	DESCRIPTION
6126-755R	Spare 2L BPA-Free Co-polyester Container
6126-751R	Air Whip Frothing Jar
98650R	Eclipse® Blender Repair Kit





QUIET SHIELD™ SOUND ENCLOSURE
FEATURES TOOL-FREE ASSEMBLY
FOR FAST AND EASY INSTALLATION,
REMOVAL AND CLEANING



**ONE TOUCH TO PERFECT
CONSISTENCY WITH
AUTO BLEND**



**BUILT-IN SENSORS EXTEND
CLUTCH LIFE WITH THE
MOTOR STOPPING WHEN THE
QUIET SHIELD™ IS OPENED**



**CAPACITIVE TOUCHPAD
WITH LCD DISPLAY WITH
SIX PROGRAMMABLE
BUTTONS, VARIABLE SPEEDS
AND PULSE ACTION**

new



**SUITABLE FOR
FROZEN DRINKS
SMOOTHIES
ICED COFFEE
ICE CREAM
FROTHING MILK**



**POWERBLEND TECHNOLOGY
DELIVERS FAST, CONSISTENT
RESULTS FOR EVEN THE
TOUGHEST RECIPES**



**STACKABLE CONTAINER WITH
MESS-FREE SPOUT FOR EASY
POURING AND LASER- ETCHED
MEASUREMENTS TO LAST
A LIFETIME**



**POWERFUL MOTOR WITH
HYBRID DRIVE COUPLING
DELIVERS POWER AND TORQUE
TO STAINLESS STEEL BLADES**



**USES
FULL CUBE
ICE**

**LIFETIME
WARRANTY**
BLADE & MOTOR DRIVE COUPLING

**BACK TO BASE
WARRANTY
3
YEARS**
PARTS & LABOUR



**OPTIMISED PROGRAMMING
WITH EASILY ACCESSIBLE
FRONT-FACING USB PORT
FOR FUTURE PROGRAMME
UPDATES**

Summit® Edge Blender

Summit® Edge Blender Ultra-quiet blending with advanced Quiet Blend™ Technology. Stackable Co-polyester container & QuietShield™ enclosure included. Removable jar pad.

CODE	MOTOR	CAPACITY	W x D x H
HBH855-UK	3.5 HP	1.4L	226 x 312 x 473mm

*SUPPLIED WITH  13A PLUG.

Summit® Edge Accessories

CODE	DESCRIPTION
6126-855	Spare 1.4L BPA-Free Co-polyester Container
6126-851	Spare 1.4L BPA-Free Co-polyester Frothing Jar



Container Rinsers & Station

new



BCR100



FULL SYSTEM IN USE



BCR200

Use your container rinser on its own or combine with the container rinser station to free up your sink and allow more cleaning flexibility.

- Save time and water costs - no more manual rinsing.
- Rinses containers in seconds.
- Stainless steel spray nozzle.
- Cleans any container up to 2 litres.
- Connects directly to available faucet.
- Suction feet hold the rinser in place.
- No electricity required.
- Simply push down to clean.
- BCR100 comes with base, nozzle and hose.
- BCR200 comes with base and accessory rinsing attachment which can be used to clean container lids.
- BCR200 base includes a removable stainless steel grate to eliminate drain blockages.
- Container rinser and station sold separately.

Container Rinser & Station Container Rinser & Station sold separately.

CODE	DESCRIPTION	W X D X H
BCR100	Container Rinser	160 x 160 x 133mm
BCR200	Container Rinser Station	231 x 231 x 224mm



TWO MODES OF OPERATION - CUSTOM PROGRAMMES CAN BE UPLOADED VIA USB



SPLASH SHIELD ENCLOSURE PREVENTS MESSY SPLATTER AND IS EASILY REMOVED FOR CLEANING - NO SCREWS

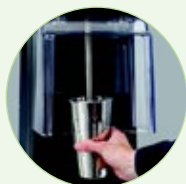

WIDE WORKING SPACE ALLOWS EASY MANOEUVRING WITHOUT RESTRICTION



HEAVY-DUTY MIXING ACTION



MIX-IN DISPENSERS SEE PAGE 248

MixStation™ Drinks Mixer HMD1000 Series Drink Mixer

- For more than just milkshakes! Flash bar drinks, blend batter & egg whites, whip cream, blend coffee drinks, prepare milk teas, mix milkshakes with soft or hard ice cream, blend ice cream with mix-ins, and much more!
- Powerful 1/3 HP induction motor, with no brushes to replace requiring less maintenance and quieter operation.
- Sealed capacitive-touch controls with single speed, start/stop rocker switch.
- Pre-programmed cycles and variable speed dial provide consistent results and customisable mixing.
- Two modes of operation - custom programming can be uploaded via USB.
- Slow Start prevents cup from being spun out of hand at beginning of mix cycle.
- Smooth, rounded corners easily wipe clean.
- Sealed capacitive-touch controls for easy cleaning.
- Magnetic splash shield prevents messy splatter and removes for cleaning.
- Removable drip tray with rounded corners.
- Comes standard with a 92g agitator for universal mixing. No cups included.

MixStation™ Drinks Mixer

CODE	MOTOR	W x D x H
HMD1000-UK	3/4 HP	279 x 320 x 667mm

*SUPPLIED WITH  13A PLUG.

Entry Level Drinks Mixer



PERFECT FOR MILKSHAKES, BAR DRINKS, EGGS & BATTERS



- 2-speed 300W motor is perfect for milkshakes, bar drinks and even eggs and batters.
- The base is easy to clean and the removable cup guide and cup rest are both dishwasher safe.
- A built-in stability bar keeps unit in place whilst mixing.
- Economically priced for restaurants and bars with small or medium volumes.

Entry Level Drink Mixer

CODE	POWER	W x D x H
60200-UK	300w	171 x 146 x 457mm

*SUPPLIED WITH  13A PLUG.

Spindle Drinks Mixers

New & Improved Design



GREAT FOR MILKSHAKES SMOOTHIES & MUCH MORE!

- Great for everything from mixing ice cream shakes to 'flashing' bar drinks and blending eggs.
- Powerful 1/3 HP motor easily powers through ingredients.
- Pulse and 3 Speeds Unique fingertip-action pulse switch that stops and starts the motor.
- Cup Guide Activation means the motor starts when mixing cup is inserted into the cup guide and stops when cup is removed.
- Hands-free operation with 2-level cup rest.
- Increased cup clearance makes it easy to remove cup after mixing.
- Heavy-duty, die-cast construction with motors that are built to last.
- HMD400R-UK model has 3 separate motors - each motor works independently and has its own power switch.

Spindle Drinks Mixers Heavy-duty machines perfect for making milkshakes and frozen cocktails. Stainless Steel malt cup(s) included. Stainless steel agitator for hard ice cream comes as standard.

CODE	MOTOR	MALT CUPS	W x D x H
A HMD200R-UK	1/3 HP	One	165 x 170 x 550mm
B HMD400R-UK	3 x 1/3 HP	Three	320 x 230 x 555mm

*ALL MODELS SUPPLIED WITH  13A PLUG.

Spindle Drinks Mixers Accessories

CODE	DESCRIPTION
48070	Spare Stainless Steel Malt Cup
C 110E	Spare Heavy-duty Stainless Steel Malt Cup
929	Stainless Steel Agitator for Mix-ins
D KLC28C	Kleen-Cup® Spindle Cleaner & Sanitiser



3-SPEED WITH UNIQUE FINGER-TIP ACTION PULSE SWITCH FOR QUICK MIXING WITHOUT CUP GUIDES

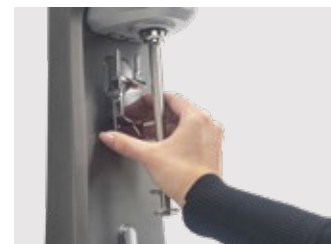

REMOVABLE CUP GUIDE PULLS OUT FOR EASY DISHWASHER CLEANUP

DELICE Hot Drink Dispenser

Countertop dispenser for mixing hot chocolate and other thick drinks.

- Versatile, reliable, compact and easy to use.
- Elegant design allows for product visibility, enticing customers and boosting product sales.
- Available with either a 3L or 5L capacity food-grade, shockproof polycarbonate bowl.
- Convenient tap on bowl which can be easily dismantled for cleaning.
- Thermostat on the side of the unit which allows for temperature adjustment up to 95°C.
- Overload protector prevents the unit from overheating.

DELICE Hot Drink Dispenser

CODE	BOWL CAPACITY	POWER	W X D X H
DELICE 3 BLACK	3L	0.8kw	240 x 290 x 410mm
DELICE 5 BLACK	5L	0.8kw	260 x 320 x 490mm

*ALL MODELS SUPPLIED WITH  13A PLUG.



new

MINIGEL PLUS Soft-Serve Ice Cream Machine

Designed to meet the needs of businesses that want to offer their customers top-quality dessert and soft-serve ice cream, cold creams, sorbets and slushies.

- Compact and easy to use.
- Enhanced mixing system for a denser and firmer ice cream.
- "RECOVERENERGY" patented system with double-wall bowl for energy saving and anti-condensation.
- Patented tank locking system.
- Tilted bowl for easy emptying.
- Backlit display.
- Product temperature display.



MINIGEL PLUS Soft-Serve Ice Cream Machine

CODE	BOWL CAPACITY	POWER	W X D X H
MINIGEL PLUS 1	1 x 6L	0.46kw	200 x 480 x 620mm
MINIGEL PLUS 2	2 x 6L	1.1kw	400 x 480 x 620mm

*ALL MODELS SUPPLIED WITH  13A PLUG.

QUICKGEL Ice Cream Machine

An innovative ice cream machine that lets you serve perfectly firm ice cream quickly, with the flexibility to create a wide range of recipes. Compact, stylish and easy to use, it features an intuitive touchscreen display with modern icons.

- Firm, high-quality ice cream with flexible recipe options.
- Compact, stylish design with intuitive touchscreen controls.
- Continuous operation with a 6-litre gravity-fed system.
- Day/night mode for total production control.
- Quick, easy cleaning with fewer parts.
- Precise dispensing via a glass detection sensor.
- Optimal product consistency is maintained in the upper tank

QUICKGEL Ice Cream Machine

CODE	BOWL CAPACITY	POWER	W X D X H
QUICKGEL	4L	0.5kw	260 x 570 x 720mm

*SUPPLIED WITH  13A PLUG.



Frozen Drink Machines

Perfect preparation of slushies, cold creams, frozen desserts and cocktails.



ICON Frozen Drink Machines

The unique and modern style of the ICON, combined with its extremely small dimensions, will allow the inclusion of this machine in any environment.

- 'RECOVERENERGY' patented system with double-wall bowl for energy saving anti-condensation.
- Electronic temperature display and control on ICON 3 models and ICON 6/1.
- Extremely compact footprint.
- Shockproof copolyester container.
- Patented steel body.
- Overload protector prevents the unit from overheating.
- Adjustable temperature.
- Air-cooled condenser.



ICON Frozen Drink Machines

CODE	NO. OF BOWLS	BOWL CAPACITY	POWER	W X D X H
A ICON 3/1	1	2.8L	0.3kw	180 x 440 x 490mm
ICON 6/1	1	6L	0.35kw	190 x 520 x 600mm
ICON 11/1	1	11L	0.55kw	210 x 540 x 670mm
ICON 3/2	2	2 x 2.8L	0.5kw	370 x 440 x 490mm
B ICON 6/2	2	2 x 6L	0.5kw	390 x 520 x 600mm
ICON 11/2	2	2 x 11L	0.75kw	430 x 540 x 670mm

*ALL MODELS SUPPLIED WITH  13A PLUG.

NG EASY Frozen Drink Machines

The NG EASY combines simplicity and reliability with a smart and unique design.

- 'RECOVERENERGY' patented system with double-wall bowl for energy saving anti-condensation.
- Bowl fixing system for better and safer fastening.
- Shockproof polycarbonate container with easy to empty inclined tank.
- Mechanical switch panel with cover.
- Conveniently compact design.
- Removable panel for condenser cleaning.
- 6L and 10L bowl models available.
- Ideal for operators who produce a higher quantity of product.



NG EASY Frozen Drink Machines

CODE	NO. OF BOWLS	BOWL CAPACITY	POWER	W X D X H
NG 6/1 EASY	1	6L	0.42kw	200 x 480 x 620mm
NG 10/1 L EASY	1	10L	0.51kw	200 x 500 x 700mm
C NG 6/2 EASY	2	2 x 6L	0.70kw	400 x 480 x 620mm
NG 10/2 L EASY	2	2 x 10L	0.74kw	400 x 500 x 700mm
NG 6/3 EASY	3	3 x 6L	0.9kw	600 x 480 x 620mm
D NG 10/3 L EASY	3	3 x 10L	1.45kw	590 x 500 x 700mm

*ALL MODELS SUPPLIED WITH  13A PLUG.

Chilled Drink Machines

Designed to cool all types of drink from fruit juices to almond milk.

new



ARCTIC DELUXE Chilled Drink Machines

Simple, easy to use and versatile, these dispensers are designed to cool all types of drink.

- Stirring paddle helps to maintain a consistent temperature and mix ingredients.
- Unibody stainless steel construction.
- Food-grade bowls and faucets easily removable.
- Hermetically sealed compressor.
- Quick and easy to dismantle for cleaning.



A

ARCTIC DELUXE Chilled Drink Machines

CODE	NO. OF BOWLS	BOWL CAPACITY	POWER	WXDXH
ARCTIC DX 12/1AA	1	12L	0.27kw	180 x 480 x 670mm
A ARCTIC DX 12/2AA	2	2 x 12L	0.29kw	360 x 480 x 670mm
B ARCTIC DX 12/3AA	3	3 x 12L	0.55kw	540 x 480 x 670mm

*ALL MODELS SUPPLIED WITH  13A PLUG.



B

A19 Chilled Drink Machine

The A19 is carefully designed with special technical features that guarantee that drinks are perfectly stirred.

- Ideal for cooling and dispensing natural fruit juice.
- Electronic temperature display and control.
- Shockproof, non-toxic polycarbonate container.
- Stainless steel body.
- Sealed hermetic compressor.
- Overload protector prevents the unit from overheating.



A19 Chilled Drink Machine

CODE	NO. OF BOWLS	BOWL CAPACITY	POWER	WXDXH
C A19	1	19L	0.3kw	320 x 400 x 720mm

*SUPPLIED WITH  13A PLUG.



C

ugolini

Triton Ice Crusher

- Triton allows you to crush ice in different sizes by adjusting the blade.
- Ice can be crushed up to 10mm in thickness.
- Safety microswitch on the feeding mouth and on the collecting tray.
- Polished aluminium feeding mouth.
- Aluminium and stainless steel internal structure.
- Body and tray are made from thermoformed alimentary plastic.
- Ribbed belt for low power absorption.

Triton Ice Crusher

CODE	POWER	CAPACITY	W x D x H
TRITON	0.35kw	2L	210 x 465 x 295mm

*SUPPLIED WITH  13A PLUG.



Nordkap Ice Crusher

- Motor with gear reducer.
- Hinged lid with microswitch.
- Adjustable ice thickness'.
- 800 r.p.m.
- Stainless steel jug.
- Aluminium structure and ABS sides.

Nordkap Ice Crusher

CODE	POWER	CAPACITY	W x D x H
NORDKAP	0.15kw	3L	205 x 235 x 491mm

*SUPPLIED WITH  13A PLUG.



Chrome Citrus Juicer

- Commercial easy to use citrus juicer with chrome body and round design.
- Stainless steel bowl is removable for cleaning and is dishwasher safe.
- Reamer and sieve are one piece to squeeze with the maximum efficiency.
- Patented safety microswitch on the cone allows the juicer to activate when the product is pushed down.
- Self-ventilated motor with helical gear reducer.
- Lid with lever and variable speed model available on request.

Apollo Juicer

CODE	POWER	RPM	W x D x H
APOLLO	0.15kw	320	210 x 210 x 290mm
APOLLO LEVER	0.15kw	320	210 x 265 x 330mm

*ALL MODELS SUPPLIED WITH  13A PLUG.



FreshMark™ PSC Electric Citrus Juicer



- Heavy-duty aluminium housing with an acid-resistant finish.
- 177.8mm diameter juice bowl with strainer.
- Reinforced Interchangeable Reamers that feature optimally designed ribs for maximum juice extraction from oranges, lemons, limes, grapefruit and more.
- Quiet Motor.
- Illuminated On/Off switch - sealed to ensure liquids can not get into the switch.
- Added spout height designed to accommodate larger cups and pitcher heights.
- Drip tray can be removed when single-serve juicing is needed.
- Removable juice bowl, splashguard, strainer, and drip tray for easy cleaning.
- Removable parts are dishwasher safe.

FreshMark™ PSC Electric Citrus Juicer

CODE	POWER	W X D X H
66900-UK	0.15kw	217 x 317 x 409mm

- Unit comes with 3 reinforced juicing lemons and limes, a medium one for oranges, and a larger one for grapefruit.
- Electric-powered juicer allows restaurants, bars, juice clubs, and smoothie bars to quickly extract maximum juice from each piece of fruit with minimum effort.
- With an exceptionally quiet brushless motor for lasting performance.
- Juice spout is a full 8.5" from the counter to allow juicing into a variety of containers, from single-serving glasses to large pitchers and storage containers.
- Metal housing with an acid-resistant finish, extra-large stainless steel container, and durable strainer and reamers are built for heavy-duty performance.
- Sealed push-button switch for safety.

FreshMark™ Heavy Duty Juicer Heavy-duty metal construction, high-quality electric juicer.

CODE	POWER	RPMS	W x D x H
HCJ967R-UK	0.25kw	1,800	260 x 254 x 470mm

- Brushless induction motor for long-lasting, quiet operation.
- Designed for continuous use with dual cooling fans.
- Polished stainless steel strainer basket with a sharp cutting blade for easy cleaning and optimal juice yield.
- Easy-to-reach height sits securely on a countertop for back-to-back juicing.
- Single-speed for easy operation.
- Durable and easy to clean Constructed with stainless steel, aluminium and BPA-free parts.
- Large diameter 76mm feed chute reduces prep time.
- Heavy-duty metal handle with safety lid interlock stops the motor before the lid is opened.
- 300 series brushed stainless steel juice bowl for ultimate durability.
- Unique funnel-shaped spout for 360° rotation to reduce splashes and drips.
- Water-resistant start/stop buttons wipe clean.
- Non-skid drip tray fits cups and blender jars, removable for easy cleaning.
- Includes base, strainer basket, juice bowl, 10L pulp bin, food pusher, drip tray and cleaning brush.

FreshMark™ otto™ Heavy Duty Centrifugal Juicer

CODE	MOTOR	RPMS	PULP BIN	W x D x H
HJE960R-UK	1.2kw	3,600	10L	322 x 527 x 638mm

*ALL JUICER MODELS SUPPLIED WITH  13A PLUG.

FreshMark™ Heavy Duty Juicer



DESIGNED FOR FAST & EASY EXTRACTION OF FRESH JUICE FROM CITRUS FRUITS



FreshMark™ otto™ Heavy Duty Centrifugal Juicer



ERGONOMIC TRITAN™ FOOD PUSHER AND LIGHTWEIGHT LID REDUCES OPERATOR FATIGUE



COMMERCIAL J-Series Juicer

The Sunkist Commercial J-Series Juicer has a quiet, heavy-duty, high-torque motor and a unique oscillating strainer that combine to efficiently extract the maximum amount of juice from the pulp.



COMMERCIAL Sectionizers

The extra-sharp, interchangeable blades of the Commercial Series Sectionizers allow you to slice citrus fruits easily, core and wedge apples and pears and slice or wedge tomatoes and mushrooms.



VISIT
FEM.CO.UK

Featured Brands



Cooking Equipment

Food is more than fuel, it's an experience. How you cook shapes the taste, texture, and consistency of every dish. Our cooking equipment helps professional kitchens deliver perfection, every time. From high-speed ovens to versatile open grills, pizza ovens, and contact toasters, we have you covered. Our products combine power, efficiency, and reliability. Whether roasting meats, baking artisan bread, or preparing high volumes, consistent results are effortless. The Cooking equipment we supply supports speed, creativity, and confidence, helping your food become your signature.





High Speed Ovens	49
Fast Stackable Pizza Oven	51
Pizza Ovens	52
Convection Ovens	54
Ventless Self-Cleaning Air Fryer	55
Multi-Cook Ovens	57
Cook & Hold Ovens	61
Smoker Cook & Hold Ovens	63
Open Grills	64
Robata Grills	64
Charcoal Ovens	65
Rotisseries	66
Microwaves	68
Induction Fryer	68
Induction Units	69
Clamshell Grills	72
Panini Grills	72
Conveyor Toasters	74
Contact Toasters	75
Egg Cooker	76
Rice Cooker	76
Sous Vide Systems	77



FITS YOUR BUSINESS

High Speed Ovens

Prática's high speed ovens are ultra-fast, high-performing ovens used for preparing and finishing **fresh** and **refrigerated** foods. The double magnetron models are also suited to preparing **frozen** foods. Each use results in excellent appearance, crunchiness, and taste.

With cutting edge technology, the ovens work with **multiple heat sources**, such as, impinged hot air, microwave and direct radiation. They are equipped with a ventless system through an easily **removable catalytic converter** and require **no extraction hood** for operation, making them easy to clean and maintain.

Connectivity with the IoT Platform: Create, edit, and organise groups, recipes, and complete menus directly on the oven or from your computer using Wi-Fi or USB Flash Drive and send them to all connected ovens.



ALL UNITS COME WITH AN EASILY REMOVABLE CATALYTIC CONVERTER FOR SIMPLE CLEANING AND MAINTENANCE



Stop wasting food

Keep your food products frozen or part-baked and make them fresh at the point of order.



Ventless technology

No need for hoods.



Any size of business

Models to fit small, medium and large businesses.



Flexibility

Increase the range of products in your offer.



Standardisation

Consistent results under continuous repetitive operation.



Easy operation

Start cooking with just two touches.



High speed

When your customers need something fast and easy to eat.



Quality food

Good food at a fraction of the time.

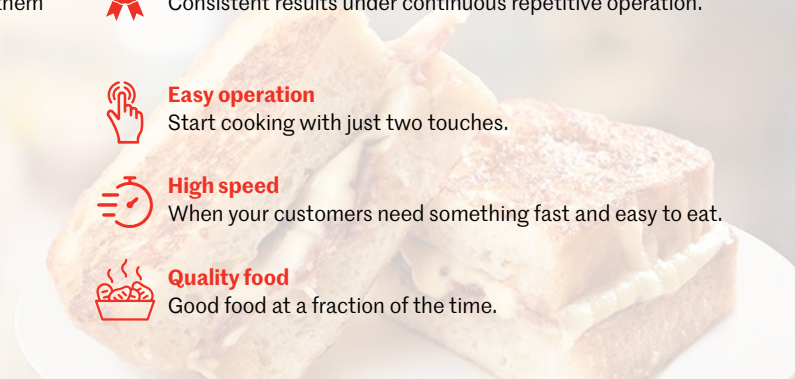

Fit Lite High Speed Oven

EASY, FAST & FIT FOR SNACK-LED OR LIMITED MENU OPERATIONS

FIT Lite is the newest addition to the Pratica FIT line, delivering professional speed-oven performance in a compact, easy-to-use design. Ideal for cafés, bakeries, and convenience operators, it's the perfect entry point into the FIT family, combining trusted engineering with fast, efficient everyday operation.

- Compact footprint, ideal for space-conscious operations.
- Single magnetron model, Ideal for fresh or refrigerated food items.
- Ideal for pre-fried savory items, pre-baked products, lasagna, pasta, sandwiches, casseroles, and other semi-prepared foods.
- Impinged air convection combined with microwave energy for heating, grilling, and toasting.
- Easy-to-use touchscreen control panel. Removable catalytic filter for easy cleaning.
- Built-in daily cleaning guide with step-by-step instructions.



AVAILABLE
SUMMER
2026

COOKING EQUIPMENT

Fit Lite High Speed Oven Includes speed grill, aluminium paddle, solid basket, bottle of oven cleaner and bottle of oven guard.

CODE	DESCRIPTION	POWER	PLUG	W X D X H
FIT LITE	Single Magnetron	3kw (1PH)	13A	386 x 680 x 619mm

Fit SM & Fit Express High Speed Ovens

Perfectly prepared food items such as breakfast sandwiches, pizzas, sub sandwiches, pastries and more! The Fit SM and Fit Express deliver exceptional flavour, appearance and crispiness every time.

- Single magnetron model is Ideal for fresh or refrigerated food items, while the double magnetron model is also suitable for cooking frozen foods.
- Fits on 60cm width countertops and cooks 30cm pizzas and two open-faced 30cm sandwiches.
- No side vents, allowing zero side clearance.
- Temperatures up to 280°C.
- Ventless design, no hoods needed.
- Removable catalytic converter allows operators to perform the cleaning without the need for a maintenance service call.
- Heat insulation prevents the surrounding area from heating up and keeps the surface cool to the touch.



FIT SM BLACK

FIT EXPRESS BLK

Fit SM & Fit Express High Speed Ovens Includes speed grill, aluminium paddle, solid basket, bottle of oven cleaner and bottle of oven guard.

CODE	DESCRIPTION	POWER	PLUG	W X D X H
FIT SM BLACK	Single Magnetron	3kw (1PH)	13A	386 x 693 x 619mm
FIT EXPRESS BLK	Double Magnetron	6.8kw (1PH)	32A*	386 x 693 x 659mm

*ALSO AVAILABLE IN 3 PHASE UPON REQUEST

Stackable High Speed Ovens

The Fit ST stackable high-speed oven features a 30cm chamber and can be stacked up to two units high. It is designed to efficiently finalise refrigerated, fresh, or frozen foods, such as breakfast sandwiches, chicken wings, muffins, lasagna, mac & cheese, sub sandwiches, and other partially prepared dishes.

- Single magnetron model is ideal for fresh or refrigerated food items, while the double magnetron model is also suitable for cooking frozen foods.
- Double the capacity without increasing bench space by stacking 2 units on top of each other.
- Fits on 60cm width countertops and cooks 30cm pizzas and two open-faced 30cm sandwiches.
- Low energy consumption without compromising results.
- Ventless design, no hoods needed.
- Removable catalytic converter allows operators to perform the cleaning without the need for a maintenance service call.



STACKABLE DESIGN

Stackable High Speed Ovens Includes speed grill, aluminium paddle, solid basket, bottle of oven cleaner and bottle of oven guard.

CODE	DESCRIPTION	POWER	PLUG	W X D X H
FIT ST SM BLACK	Single Magnetron	3kw (1PH)	13A	518 x 697 x 425mm
FIT ST DM BLACK	Double Magnetron	6.8kw (1PH)	32A*	518 x 697 x 425mm

*ALSO AVAILABLE IN 3 PHASE UPON REQUEST

High Speed Oven Accessories



MUST HAVE ACCESSORY FOR PROFESSIONAL-LOOKING GRILL MARKS

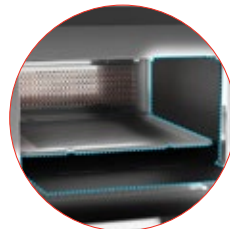

INSTALLS AND REMOVES IN SECONDS. NO TOOLS REQUIRED.



- Dual plates ensure uniform grilling and reduced cook times
- Heavy-duty construction for long-term durability.
- Accommodate a variety of foods with an opening range of 12mm to 74.6mm between top and bottom plates.
- Easy installation, use and cleaning.
- Dishwasher safe.

- Shields the oven cavity from grease, dirt and splashes.
- Ensures faster cleaning routines, minimises the need for harsh chemicals and extends the lifespan of your equipment.
- Made from durable, heat-resistant materials.

Panini Press Accessory

CODE	SUITABLE USE
800552	FIT LITE, FIT SM, FIT EXPRESS, FIT ST

Cavity Protection Liner

CODE	SUITABLE USE
800591	FIT LITE, FIT SM, FIT EXPRESS, FIT ST

XL High Speed Oven

The Fit XL high-speed oven features a 16-inch chamber and is designed to efficiently finalise refrigerated, fresh, or frozen foods, such as breakfast sandwiches, chicken wings, muffins, lasagnas, mac & cheese, sub sandwiches, and other partially prepared dishes.

- The larger 40cm chamber is capable of handling larger portions, it is ideal for medium and large businesses.
- Large productions are done quickly and always in uniform.
- Fits on 70cm width countertops and cooks 40cm pizzas.
- Adjustable temperature from 30°C to 280°C.
- Daily cleaning guide with explanatory videos displayed on the screen, demonstrating the step-by-step process.
- Low energy consumption without compromising results.
- Ventless design, no hoods needed.
- Removable catalytic converter allows operators to perform the cleaning without the need for a maintenance service call.



COMPACT ON THE OUTSIDE,
SPACIOUS ON THE INSIDE

COOKING EQUIPMENT

XL High Speed Oven Includes speed grill, aluminium paddle, solid basket, bottle of oven cleaner and bottle of oven guard.

CODE	DESCRIPTION	POWER	PLUG	W X D X H
FIT XL BLACK	Double Magnetron	6.8kw (1PH)	32A*	488 x 795 x 658mm

*ALSO AVAILABLE IN 3 PHASE UPON REQUEST

Fast Stackable Pizza Oven

Designed to ensure swift and exceptional delivery, even during peak demands, the Forza STi proves to be an ideal solution for QSR establishments, as well as pizzerias, bakeries, hotels, kiosks, and convenience stores.

- The production of pizzas, flatbreads, cookies, and more becomes even better with the Forza STi, ensuring superior appearance, flavour, and texture.
- Prepares pizzas up to 40cm: fresh, or par-baked dough, thin or thick crust.
- Secures consistent results: through precise control, even heat distribution, rapid cooking, built-in sensors, and customisation options.
- Compact, stackable and modern design combined with a display-type door makes the unit perfect for front-of-house.
- Temperatures up to 330°C.
- Ventless design, no hoods needed.
- Removable catalytic converter allows operators to perform the cleaning without the need for a maintenance service call.



STACKABLE
DESIGN



Fast Stackable Pizza Oven Includes a 16" pizza screen, an aluminium paddle, a door cleaning tool, bottle of oven cleaner and bottle of oven guard.

CODE	CAPACITY	POWER	PLUG	W X D X H
FORZA STi	1 x 16" Pizza	6.6kw (1PH)	32A	705 x 788 x 340mm

Pizza Ovens



Stromboli

CODE	PIZZAS	POWER	PLUG	INTERNAL	W x D x H
STROMBOLI	2 x 220mm (8.5")	1.6kw	13A	410 x 360 x 80mm	580 x 490 x 245mm
STROMBOLI 2	4 x 220mm (8.5")	3.2kw	16A	410 x 360 x 80mm	580 x 490 x 420mm

- Stainless steel structure.
- Stone baking deck.
- Shock-proof, coated heating elements.
- Air vent with shutter.



NOW WITH
TOP VENTS



- Stainless steel construction.
- Stone baking deck.
- Shock-proof heating elements.
- Air-hole.
- Ceramic fibre lining.
- Adjustable thermostats.

Vulcano

CODE	PIZZAS	POWER	PLUG	INTERNAL	W x D x H
VULCANO 2C	4 x 300mm (12")	6.4kw	32A*	505 x 520 x 115mm	745 x 695 x 490mm

*ALSO AVAILABLE IN 3 PHASE UPON REQUEST

Capacity:

- 2x 300mm (12") per deck.
- 1x Tray (30 x 40cm) per deck.



- Stainless steel construction.
- Door with panoramic glass.
- Aluminium-plated cooking chamber.
- Stone baking deck.
- Independent top-bottom heating elements.
- 2 thermostats (1 for baking deck and 1 for chamber).
- Safety thermostat.
- Aluminium stands come with runners for dough boxes.

Lipari

CODE	PIZZAS	POWER	PLUG	INTERNAL	W x D x H
LIPARI 2C	8 x 300mm (12")	2 x 4.5kw	32A*	620 x 620mm	930 x 770 x 672mm

*ALSO AVAILABLE IN 3 PHASE UPON REQUEST

Capacity:

- 2x 300mm (12") per deck.
- 1x Tray (60 x 40cm) per deck.

Aluminium Stand

CODE	W x D x H
28010239	620 x 620 x 1150mm

Hood

CODE
LIPARI HOOD

Pizza Ovens



A



B

- Stainless steel construction.
- 2 thermostats (1 for baking deck & 1 for chamber).
- Air vent with shutter.
- Aluminium coated metal internal chamber walls.
- Stone baking deck.
- Door with glass window.
- Interior lighting.

Vesuvio

CODE	PIZZAS	POWER	PLUG	INTERNAL	W x D x H
A VESUVIO 70X70	4 x 350mm (14")	5.9kw	32A	700 x 700mm	995 x 900 x 395mm
VESUVIO 85X70	4 x 360mm (14")	7.2kw	32A	850 x 700mm	1190 x 905 x 395mm
B VESUVIO 105X70	6 x 330mm (13")	9kw (3PH)	32A	1050 x 700mm	1395 x 920 x 395mm

*ALSO AVAILABLE IN 3 PHASE UPON REQUEST

Capacity:

- 1x Tray (60 x 40cm) - 70X70 Model.
- 2x Trays (60 x 40cm) - All other single deck models.



SHOWN WITH OPTIONAL HOOD



- Stainless steel construction.
- 2 thermostats per deck (1 for baking desk and 1 for chamber).
- Air vent with shutter.
- Aluminium coated metal internal chamber walls.
- Stone baking deck.
- Door with glass window.
- Interior lighting.

ALUMINIUM STANDS ALSO AVAILABLE IN 1150MM HEIGHT

Capacity:

- 2x Trays (60 x 40cm) per deck.

Vesuvio Double Deck

CODE	PIZZAS	POWER	PLUG	INTERNAL	W X D X H
VESUVIO 2C 70X70	8 x 350mm (14")	2 x 5.9kw	2 x 32A*	700 x 700mm	1040 x 920 x 675mm
VESUVIO 2C 85X70	8 x 360mm (14")	2 x 7.2kw	2 x 32A*	850 x 700mm	1190 x 905 x 720mm
VESUVIO 2C 105X70	12 x 330mm (13")	2 x 9kw (3PH)	2 x 32A	1050 x 700mm	1395 x 920 x 660mm

*ALSO AVAILABLE IN 3 PHASE UPON REQUEST

Hoods

CODE	W X D X H
VESUVIO HOOD 70X70	992 x 1034 x 171mm
VESUVIO HOOD 85X70	1192 x 1035 x 171mm
VESUVIO HOOD 105X70	1392 x 1112 x 221mm

*ALL HOODS SUPPLIED WITH INDEPENDENT 13A PLUG.

Aluminium Stands with runners for dough boxes.

CODE	DESCRIPTION	W X D X H
28010235	For 70x70	995 x 855 x 950mm
28010245	For 85x70	1195 x 855 x 950mm
28010255	For 105x70	1395 x 855 x 950mm

AETNA Pizza Oven

New top of the range pizza oven...

- The perfect pizza oven for operators producing high quantities or running the oven for many hours a day.
- Easy and intuitive 5" touch electronic control panel with separate temperature control for upper and lower heating elements.
- Daily and weekly pre-heating setting with fast recovery in between batches.
- Extremely flexible programming to adapt to any recipe and type of dough with recipe uploading via USB and remote programming option.
- ECO programme alternates top and bottom heater operation to lower the peak absorbed power.
- Perfect even and uniform heat distribution of the bottom stone.
- Cooks 6 pizzas in 3.5 minutes without losing performance after batches.
- Deck and top with shockproof heating elements.
- High heating power, max temperature 450°C.
- Full insulation and thermal inertia to save energy.
- Strong, durable construction.
- **Fume hood powerful with LED lights (optional).**



SHOWN WITH OPTIONAL PROOFING CABINET & HOOD



EASY AND INTUITIVE TOUCH CONTROL



Capacity:

- 2x Trays (60 x 40cm) per deck.

AETNA Pizza Oven

CODE	PIZZAS	POWER	PLUG	INTERNAL	W X D X H
AETNA 105X70	6 x 330mm (13")	11.4kw (3PH)	32A	1050 x 700mm	1480 x 1300 x 380mm
AETNA 105X70 2C	12 x 330mm (13")	2 x 11.4kw (3PH)	32A	2 x 1050 x 700mm	1480 x 1300 x 760mm
AETNA 105X70 3C	18 x 330mm (13")	3 x 11.4kw (3PH)	32A	3 x 1050 x 700mm	1480 x 1300 x 1140mm

Proofing Cabinet

CODE	DESCRIPTION
304032021C	Proofing Chamber for 105X70
304032022C	Proofing Chamber for 105X70 2C

Hood

CODE	DESCRIPTION
304022CFA	Hood for 105X70

Aliseo Convection Oven



PLUS MODEL COMES WITH HUMIDIFIER TURBO FAN FOR EVEN AND EFFECTIVE HEAT DISTRIBUTION

- Stainless steel construction incl. chamber.
- Comes with 4 removable racks for ease of cleaning.
- Seamless, round-cornered chamber to prevent contamination and easy to clean.
- Double glass stainless steel door and Internal lighting.
- Double-fan heat distribution.
- Thermostat from 25°C to 300°C.
- Timer up to 120 minutes.



4 REMOVABLE RACKS AS STANDARD



ALISEO 4 HAS DUAL VENTILATION

Aliseo Convection Oven

CODE	POWER	PLUG	SHELVES	TRAY DIMS	W X D X H
ALISEO 2/3	2.6kw	13A	4	425 x 321mm	600 x 625 x 515mm
ALISEO 4	3.4kw	16A	4	600 x 400mm (1/1GN)	820 x 760 x 610mm
ALISEO 4 PLUS	6.4kw (3PH)	16A	4	600 x 400mm (1/1GN)	820 x 760 x 610mm

Ventless Self-Cleaning Air Fryer

Healthy, crispy and ready in minutes - without the need for oil or extraction.

The new HOP air fryer oven fits anywhere and is easy for everyone to use every day. It's designed for all kinds of frozen ready-made foods. With a new air frying system, it delivers reliable performance and great results, offering tasty, crispy and healthy meals.

- ✔ **Ventless System:** Catalytic/condensation system ensures clean, odour-free air.
- ✔ **High Cook Capacity:** Up to 2.2kg of chips in 8-10 minutes.
- ✔ **V Dry System:** Removes moisture for perfect texture, crispiness and browning.
- ✔ **Self-Cleaning:** Automatic wash cycles via one-touch keyboard.
- ✔ **Stackable:** Optional stacking kit for increased capacity.
- ✔ **Programmable:** Basket rotation and menu programming for consistent cooking.
- ✔ **No oil:** Eliminates costs for oil purchase, filtration and disposal.
- ✔ **No extraction:** The unit can be used front-of-house if required.
- ✔ **Connectivity:** USB port, Wi-Fi/Cloud and web server for remote menu management.
- ✔ **Web server:** Easily connect to smartphones and tablets to access to menu recipe book.



new



WARRANTY
1
YEAR
PARTS & LABOUR



INSIDE UNIT WITH ROTATING BASKET



UNIT SHOWN STACKED

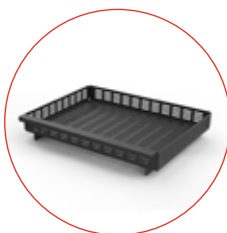

ACCESSORIES ALSO AVAILABLE SEE FEM.CO.UK

Ventless Self-Cleaning Air Fryer Supplied with rotating basket, flat tray and a bottle of detergent.

CODE	TEMPERATURE	POWER	PLUG	CHAMBER DIMENSIONS	W X D X H
HOPLCNCE	Max 260°C	9.5kw (3PH)	16A	455 x 320 x 285mm	732 x 871 x 593mm



Converge® Multi-Cook Ovens

Unrivalled cooking power and flexibility.

Converge® Multi-Cook Ovens can steam, bake, grill and air fry – all at once – without sacrificing quality. Each chamber features individual temperature, humidity and cook time control to execute multiple cooking applications simultaneously.

THREE OVENS IN ONE

Available with two or three independent oven chambers. Significantly increase food production capacity, without increasing costs. Execute a variety of cooking applications – with zero flavour transfer.

STRUCTURED AIR TECHNOLOGY

Deliver the same high-quality food every time. Structured Air Technology provides superior cooking evenness with vertical air. This optimised focused heat delivers faster, more efficient and consistent cooking than other methods. No food degradation. No hot or cold spots.

FOOD SAFETY

Guarantee food items are cooked to precise internal temperatures with removable food probes in each chamber (Deluxe models).



BOILERLESS STEAM GENERATION

Improve oven reliability with a boilerless steam generation in each individual oven chamber. Eliminate required maintenance and costs associated with traditional boiler parts and labour.



SELF-CLEANING DESIGN

Automatic, self-cleaning programmes do the dirty work for you and your employees. Saving both time and labour costs. Four cleaning options from 'rinse' to 'heavy clean' use safe, convenient cleaning tablets.

Converge® Multi-Cook Ovens

Converge® multi-cook ovens combine the versatility of combi cooking and flexibility of a multi-cook oven with the power of Structured Air Technology®. Three independent combis in one footprint –all in a ventless, self-cleaning design.

Converge® Simple-Control Multi-Cook Ovens



- Three cooking modes—steam, convection, and combination.
- Programmable, touchscreen control.
- Easy recipe upload/download via USB port.
- Four fully automated cleaning cycles.
- Integrated catalyst wash.
- LED illuminated door handle is designed for the needs of the busy kitchen, and provides visual notification of the oven status.
- Absolute Humidity Control™ allows for the selection of any humidity level from 0-100% to maximise food quality, texture, and yield.

* ALL OF THE ABOVE FEATURES APPLY TO BOTH SIMPLE AND DELUXE MODELS

Converge® Simple-Control Multi-Cook Ovens

CODE	DESCRIPTION	CONTROL	PAN CAPACITY	POWER	PLUG	W X D X H
CMC-H2H SX	2 Shelf	Simple	2 GN 1/1 pans or 2 GN 2/3 pans	8.9kw (3PH)	16A	621 x 1023 x 975mm
CMC-H3H SX	3 Shelf	Simple	3 GN 1/1 pans or 3 GN 2/3 pans	13.4kw (3PH)	32A	621 x 1023 x 1168mm

Converge® Deluxe-Control Multi-Cook Ovens



- Deluxe models include ChefLinc™ - the cloud-based remote oven management system.
- View real-time connectivity status, cooking state, HACCP data, service alerts and more from any location.
- Create, manage and push recipes and regional menus with a centralised recipe library.
- Minimise downtime and reduce service calls with real-time service diagnostics and detailed action steps.
- Effortlessly record, monitor and store operational and cooking data to improve kitchen efficiency and profits.

Converge® Deluxe-Control Multi-Cook Ovens

CODE	DESCRIPTION	CONTROL	PAN CAPACITY	POWER	PLUG	W X D X H
CMC-H2H DX	2 Shelf	Deluxe	2 GN 1/1 pans or 2 GN 2/3 pans	8.9kw (3PH)	16A	621 x 1023 x 975mm
CMC-H3H DX	3 Shelf	Deluxe	3 GN 1/1 pans or 3 GN 2/3 pans	13.4kw (3PH)	32A	621 x 1023 x 1168mm

The VECTOR™

Four Ovens in One

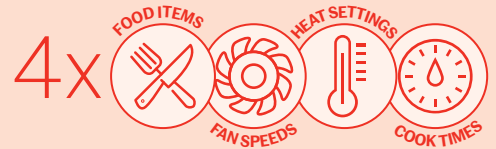

The secret to Vector® Multi-Cook Ovens lies in **Structured Air Technology®**. This innovation offers up to **four ovens in one** – each chamber with independent temperature, fan speed and cook time control. Cook up to four different food items simultaneously with no flavour transfer. Cook food the way it's meant to be cooked – to perfect your dishes.

- **Waterless operation** - Reduce installation and operating costs. No plumbing, drains, filtration or associated maintenance.
- **Reduce skilled labour** – Eliminate steps in food production and the need for employees to watch and rotate pans.
- **Superior consistency** – Delivery the same high-quality food every time. Structured Air Technology provides cooking evenness and quality. No food degradation. No hot and cold spots.
- **Advanced control** – Designed intentionally simple, an intuitive, user-friendly interface features programmable recipes.

COOKING EQUIPMENT



VERTICAL AIR CURTAINS
ELIMINATE HEAT LOSS, ENABLING THE DOOR TO BE OPENED WHILE COOKING.

NO VENTILATION REQUIRED

HOLES IN THE JET PLATES DIRECT AIR UP AND DOWN FOR **EVEN COOKING** WITH NO HEAT SPOTS

EACH CHAMBER HAS ITS OWN INDEPENDENT AIR PATH, HEAT SOURCE AND FAN

COOK 2X FASTER THAN A TRADITIONAL OVEN – WITH BETTER FOOD QUALITY

COOK TWICE AS MUCH FOOD IN THE SAME AMOUNT OF TIME AS TRADITIONAL OVENS



Upgrade to Deluxe Control...

- Advanced control with images.
- Unlimited steps and actions for each recipe.
- Work instructions.
- HACCP and technical data.
- Wi-Fi capabilities.



Compatible with ChefLinc™, Alto-Shaam's cloud-based remote oven management system, which features an easy-to-use dashboard to streamline processes, reduce labour and maximise profits. It provides operators with complete control of their ovens, menus and business with real-time data at their fingertips.

VECTOR™ H-Series Multi-Cook Oven

The new design Vector™ H Series Multi-Cook Oven features LED door lighting, an improved hinge system, a new solid handle design, a larger glass viewing area, and exclusive Structured Air Technology™.



- Includes**
- 2 wire stainless steel racks.
 - 2 jet plates per cooking chamber.
 - 102mm adjustable legs.



- Includes**
- 3 wire stainless steel racks.
 - 3 jet plates per cooking chamber.
 - 102mm adjustable legs.



- Includes**
- 4 wire stainless steel racks.
 - 4 jet plates per cooking chamber.
 - 102mm adjustable legs.

VECTOR™ H-Series Simple-Control Multi-Cook Ovens

CODE	DESCRIPTION	PAN CAPACITY	POWER	PLUG	W X D X H
VMC-H2H SX	2 Shelf	2 GN 1/1 or 2 half size sheet pans	6.5kw (1PH)	32A*	546 x 1003 x 752mm
VMC-H3H SX	3 Shelf	3 GN 1/1 or 3 half size sheet pans	9.6kw (3PH)	16A	546 x 1003 x 929mm
VMC-H4H SX	4 Shelf	4 GN 1/1 or 4 half size sheet pans	12.7kw (3PH)	32A	546 x 1003 x 1108mm

*PLUG TYPE/POWER PHASE AS STANDARD

VECTOR™ H-Series Deluxe-Control Multi-Cook Ovens with advanced control and images, HACCP and technical data, unlimited steps and actions for each recipe, work instructions and Wi-Fi capabilities.

CODE	DESCRIPTION	PAN CAPACITY	POWER	PLUG	W X D X H
A VMC-H2H DX	2 Shelf	2 GN 1/1 or 2 half size sheet pans	6.5 kw (1PH)	32A*	546 x 1003 x 752mm
B VMC-H3H DX	3 Shelf	3 GN 1/1 or 3 half size sheet pans	9.6kw (3PH)	16A	546 x 1003 x 929mm
C VMC-H4H DX	4 Shelf	4 GN 1/1 or 4 half size sheet pans	12.7kw (3PH)	32A	546 x 1003 x 1108mm

*PLUG TYPE/POWER PHASE AS STANDARD

VECTOR™ Multi-Cook Oven Accessories

CODE	DESCRIPTION
VH-STAND	H-Series Mobile Stand w/ 4 runners (650 x 850 x 720mm)
D ACRP	Aluminium 1/1 non-stick coated ridged pan
E ACFP	Aluminium 1/1 non-stick coated flat pan
F 132560	Aluminium 1/1 non-stick coated egg pan
736030	Round 12" perforated pizza pan
810CM15	BestGrip single oven mitt (380mm long)
CHEMCO-CLEAN	Chemco Oven Spray Cleaner (6 pack)
CHEMCO-GUARD	Chemco Oven Spray Guard (6 pack)



Alto-Shaam Cook & Hold Ovens

Engineered for overnight success and maximum return on investment.

HALO HEAT



DELUXE CONTROL
AS STANDARD WITH
'DX' MODELS.



COOKING EQUIPMENT

Cost Savings

Increase productivity. Provide a better distribution of workloads and relieve multiple pieces of equipment. Roast, proof, braise, reheat, ferment, sous-vide, hold and more in the same cabinet.

Place anywhere with ventless design. No oven hood or outside venting required. Waterless design reduces installation and operating costs.

Natural meat tenderisation. Halo Heat Technology delivers a moist, tender product. Make the most of less expensive, underutilised cuts of meat and produce a better quality product.

Purposeful Design

Removable food probes. Designed to improve safety and be easily replaced, providing greater reliability and reducing oven downtime.

In-door lighting. Put product on display with a glass door option and in-door, adjustable LED lighting.

Easy to clean. Simply remove shelves and wipe clean. No moving parts or water in the oven makes cleaning effortless.

Features a low-density, unique thermal cable that is wrapped around the sides and bottom of the oven cavity.

Gentle heat is distributed evenly throughout the oven cavity.

Unique thermal cable emits even, temperature and pulses on and off throughout the cooking and holding process.

No water needed. Food retains its natural moisture.



No fans, added humidity or harsh heating elements to degrade food quality.

Sealed, static cooking environment traps natural flavour and juices, reducing shrink, improving food quality and extending hold life.

Controllable precise temperatures with minimal intensity made possible by the unique thermal cable, leaving food full of moisture and flavour.

Why Halo Heat?
Higher yields. Better food quality.

ALTO-SHAAM

Simple & Deluxe Control Cook & Hold Ovens



- Cook by time or probe with Simple or Deluxe controls. Probes sense internal product temperature and automatically convert oven from cook mode to hold mode once parameters have been reached.
- Halo Heat technology honours every cut of meat from end to end – providing a better quality product at a lower cost. One hour in the Cook & Hold Oven is equivalent to 1-2 days of dry ageing.
- A ventless waterless design. Lower costs with energy-efficient operation and no water hookups or traditional kitchen hood required.
- Labour-free, overnight cooking and effortless operation reduces labour costs and increases productivity.
- Advanced controls – designed intentionally simple – feature an intuitive, user-friendly interface and programmable recipes to ensure consistency with each cook.

Deluxe models also include:

- ChefLinc™ remote oven management system provides operators complete control of their ovens, menus and business with real-time data at their fingertips. Operators can seamlessly create, manage and distribute recipes to ovens in multiple locations through the cloud.
- HACCP data logger automatically tracks food temperature readings and operation mode by date and time – all downloadable onto a USB flash drive.
- SureTemp™ heat recovery system assures immediate compensation for any heat loss whenever the oven door is opened and provides an audible reminder if the door is left open for more than three minutes.



E



COOKING EQUIPMENT

Includes

- Core temperature probe.
- 2 wire shelves.
- 1 internal drip pan.
- 1 external drip tray.
- 19mm non-skid feet.

Includes

- Core temperature probe.
- 3 wire shelves.
- 1 internal drip pan.
- 1 external drip tray.
- 64mm castors.

Includes

- Core temperature probe.
- 3 wire shelves.
- 1 internal drip pan.
- 1 external drip tray.
- 64mm castors.

Includes

- Core temperature probe.
- 3 wire shelves.
- 1 internal drip pan.
- 1 external drip tray.
- 64mm castors.

Includes

- Core temperature probe.
- 6 wire shelves.
- 2 internal drip pans.
- 1 external drip tray.
- 89mm castors.

Simple Control Cook & Hold Ovens

CODE	PROD. CAPACITY	PAN CAPACITY	POWER	PLUG	W X D X H
300-TH/SX	16kg	3 x 1/1 GN D100mm	0.7kw	13A	431 x 665 x 620mm
B 500-TH/SX	18kg	5 x 1/1 GN D65mm	2.8kw	13A	459 x 724 x 806mm
750-TH/SX	45kg	10 x 1/1 GN D65mm	2.8kw	13A	653 x 851 x 805mm
D 1000-TH/SX	54kg	8 x 1/1 GN D65mm	2.5kw	13A	573 x 851 x 978mm
1200-TH/SX	108kg	16 x 1/1 GN D65mm	5kw	32A	573 x 845 x 1795mm
1750-TH/SX	90kg	20 x 1/1 GN D65mm	5.1kw	32A	653 x 853 x 1438mm

Deluxe Control Cook & Hold Ovens

DELUXE CODE	PLUG
A 300-TH/DX	13A
500-TH/DX	13A
C 750-TH/DX	13A
1000-TH/DX	13A
1200-TH/DX	32A
E 1750-TH/DX	32A

FACTORY INSTALLED OPTIONS

Window door, Pass-through design, Left-hand door hinge.

ACCESSORIES

Bumper Guards, Carving holders, Door lock with key, Drip Pans, Stacking kit, Shelves, Security panel with key lock, Legs, GN pans, Sheet pans.

Classic-Control Cook & Hold Ovens



- HALO HEAT... a controlled, uniform heat source that maintains close temperature tolerances throughout the cooking and holding function.
- Offers uniform and consistent cooking on a daily basis, low shrinkage of bulk or portion-cut protein items, higher food moisture content, and significantly longer holding life.
- Cooks, roasts, re-heats, and holds in the same cabinet with set-and-forget controls to provide a better distribution of workloads.
- Cooks by time and automatically converts from cook mode to hold mode.
- Simple manual controls make adjusting time and temperature settings easy.
- Stackable design for additional capacity.



COOKING EQUIPMENT



Includes

- 2 wire shelves.
- 1 internal drip pan.
- 1 external drip tray.
- 64mm castors.

Includes

- 3 wire shelves.
- 1 internal drip pan.
- 1 external drip tray.
- 64mm castors.

Includes

- 3 wire shelves.
- 1 internal drip pan.
- 1 external drip tray.
- 89mm castors.

Includes

- 6 wire shelves.
- 2 internal drip pans.
- 1 external drip tray.
- 127mm castors.

Classic-Control Cook & Hold Ovens

CODE	PRODUCT CAPACITY	PAN CAPACITY	POWER	PLUG	W X D X H
A 500-TH-II	18kg (40lb)	4 x 1/1 GN D65mm	2.8kw	13A	483 x 675 x 848mm
B 750-TH-II	45kg (100lb)	10 x 1/1 GN D65mm	2.4kw	13A	676 x 802 x 809mm
C 1000-TH-II	54kg (120lb)	8 x Sheet Pans (450x650mm)	2.4kw	13A	597 x 802 x 1021mm
D 1000-TH-I	108kg (240lb)	16 x Sheet Pans (450x650mm)	4.9kw	32A	608 x 802 x 1920mm

FACTORY INSTALLED OPTIONS

Window door, Pass-through design, Left-hand door hinge.

ACCESSORIES

Bumper Guards, Carving holders, Door lock with key, Drip Pans, Stacking kit, Shelves, Security panel with key lock, Legs, GN pans, Sheet pans.

Smoker Cook & Hold Ovens



These Smokers offer all the features and benefits of a Cook & Hold oven, with all the flavour possibilities of real wood smoke.

- Introduce new menu items without added sodium, fats or sugars.
- Smokes with real wood chips – no pressure cooking, no artificial smoke flavour.
- Smoke timer offers a choice of mild, medium, or heavy smoke flavour.
- Cooks, smokes, and holds meats, poultry, and fish.
- Cold smokes fish and cheese.

- Induces natural enzyme action in meat for tenderising.
- Less energy usage than conventional ovens.
- Reduces labour and evens-out workloads.
- Non-magnetic stainless-steel interior, racks, and shelves resist corrosion.
- Stackable design for additional capacity.
- **Simple control models** feature icon-based, touch controls and a knob to set temperatures, smoke, cook and hold times. Cook by time or temperature probe and store up to eight programmable recipes.

WOODCHIPS ALSO AVAILABLE



Classic-Control



Includes

- 2 wire shelves + 1 rib rack.
- 1 internal drip pan.
- 1 external drip tray.
- Sample bag of woodchips.
- 89mm castors.

Includes

- 4 wire shelves + 2 rib racks.
- 2 internal drip pans.
- 1 external drip tray.
- Sample bag of woodchips.
- 127mm castors.

Simple Control

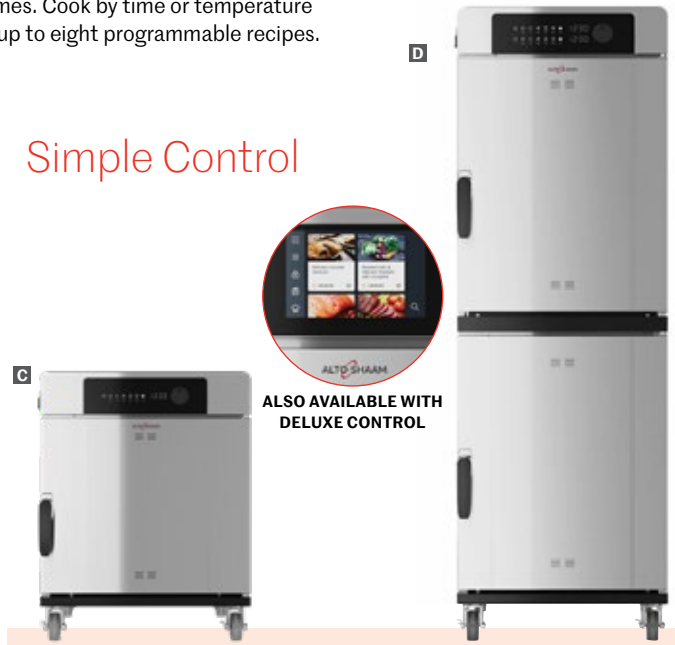

ALSO AVAILABLE WITH DELUXE CONTROL

Includes

- Core temperature probe.
- 2 wire shelves + 1 rib rack.
- 1 internal drip pan.
- 1 external drip tray.
- Woodchip tray & bag of woodchips.
- 64mm castors.

Includes

- Core temperature probe.
- 4 wire shelves + 2 rib racks.
- 2 internal drip pans.
- 1 external drip tray.
- Woodchip tray & bag of woodchips.
- 89mm castors.

Classic & Simple Control Smoker Cook & Hold Ovens

CODE	DESCRIPTION	PRODUCT CAPACITY	PAN CAPACITY	POWER	PLUG	WXDXH
A 767-SK	Classic Control	45kg (100lb)	9 x 1/1 GN D65mm	2.8kw	13A	676 x 802 x 848mm
B 1767-SK	Classic Control	90kg (200lb)	18 x 1/1 GN D65mm	5.6kw	32A	686 x 832 x 1572mm
1000-SK/I	Classic Control	108kg (240lb)	14 Sheet Pans (450 x 650mm)	5.5kw	32A	608 x 819 x 1920mm
C 750-SK/SX	Simple Control	45kg (100lb)	9 x 1/1 GN D65mm	4.2kw	32A	653 x 851 x 805mm
1000-SK/SX	Simple Control	54kg (120lb)	7 x 1/1 GN D65mm	4.1kw	32A	573 x 851 x 978mm
1750-SK/SX	Simple Control	90kg (200lb)	18 x 1/1 GN D65mm	5.8kw	32A	653 x 853 x 1448mm
D 1200-SK/SX	Simple Control	108kg (240lb)	14 x 1/1 GN D65mm	5.7kw	32A	573 x 845 x 1795mm

ACCESSORIES

Bumper Guards, Carving holders, Door lock with key, Drip Pans, Stacking kit, Shelves, Security panel with key lock, Legs, Gastronorm pans.

Open Grills

new

Designed and manufactured entirely by Pujadas in high-quality stainless steel. Perfect for indoor, open or outdoor kitchens.

TEMPERING GRILL AND BAR

LARGE COOKING SURFACE AVAILABLE WITH ROD BAR AND V-SHAPED GRILLS.

REFRACTORY BRICK BASE

THERMALLY INSULATED BODY FOR GREATER EFFICIENCY AND BETTER PROTECTION FROM THE OUTSIDE

HANDWHEEL FOR EASY ELEVATION UP TO 400MM
GREASE COLLECTOR

AVAILABLE WITH BLACK, RED OR STAINLESS STEEL COATING

GREASE COLLECTOR

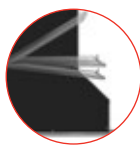

TILTING GRILL IN THREE POSITIONS: CHARCOAL LIGHTNING, FLAT FOR COOKWARE, FAT COLLECTING.

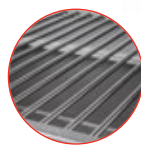

LARGE COOKING SURFACE AVAILABLE WITH ROD BAR AND V-SHAPED GRILLS.



MOBILE CABINET WITH GN 1/1 RAILS, TWO STORAGE SHELVES, AND FOUR CASTORS, TWO AT THE FRONT WITH BRAKES.

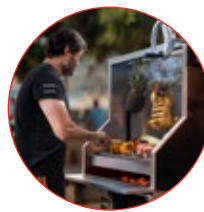

Open Grills Each open grill comes with a charcoal poker, stainless steel Versagrip tongs, an ash shovel and a cleaning brush. Available with rod or v-shaped grill bars, black as standard. Grill dimensions 862 x 536 x 20mm.

Open Grills with Rod Bars

CODE	DESCRIPTION	COLOUR	W X D X H
A 8581010B	With Mobile Cabinet	Black	1040 x 740 x 1670mm
B 8581000B	Countertop	Black	1040 x 740 x 1000mm
8581030B	Without Refractory Brick Base	Black	980 x 683 x 955mm

Open Grills with V-Shaped Bars

CODE	DESCRIPTION
8581011B	With Mobile Cabinet
8581001B	Countertop
8581031B	Without Refractory Brick Base

Robata Grills



FIVE REMOVABLE RACKS FOR ALL TYPES OF COOKING

REMOVABLE 65MM GN 2/3 CONTAINER

2 REMOVABLE ROD GRILLS, IDEAL FOR INTENSE EMBERS

5 X 100MM GN 1/9 CONTAINERS FOR INGREDIENTS - MOBILE VERSION ONLY

TWO STORAGE SHELVES



OPEN GRILL WITH 3 COOKING LEVELS

AVAILABLE WITH BLACK, RED OR STAINLESS STEEL

REFRACTORY BRICK BASE

GN 1/1 RAILS

FRONT WHEELS WITH BRAKES

new

Robata Grills Each open grill comes with a charcoal poker, stainless steel Versagrip tongs, an ash shovel and a cleaning brush. Available with rod grill bars only, black as standard. Grill dimensions 440 x 357mm.

CODE	DESCRIPTION	COLOUR	W X D X H
C 8582010B	With Mobile Cabinet	Black	1040 x 520 x 850mm
8582000B	Countertop	Black	1040 x 740 x 1000mm



CHARCOAL COOKING ESSENTIALS
SEE PAGE 204

Charcoal Ovens

Add the smokey flavour of charcoal to meat, fish, seafood, vegetables, rice, pizza, desserts, pastries and more.

Inner chamber design supports air recirculation, guaranteeing a homogeneous distribution of heat and better performance of the combustible material. Perfect for indoor & outdoor Cooking!

NEW MODELS
NOW SUPPLIED WITH FULL CHIMNEY SYSTEM & ACCESSORIES

Working range of temperatures between 250°C and 350°C.

Durable stainless steel construction providing greater endurance.

Thermometer at the bottom of the oven provides accurate temperature and greater protection.



Reinforced oven door for robustness, fullness and avoid deformations.

Regulator with spring system and numerical position indicator.

Using charcoal or wood chips instead of gas or electricity cooks items 40% faster than conventional chargrills.

Countertop Charcoal Ovens Each oven comes with a stainless steel grill, a set of tongs, a charcoal poker, an ash shovel and a cleaning brush.

CODE	COLOUR	PRODUCTION	CATERS FOR	W X D X H	GRILL L X W
850500SS	Stainless Steel	30kg	40-50 diners	690 x 570 x 930mm	580 x 367mm
850500B	Black	30kg	40-50 diners	690 x 570 x 930mm	580 x 367mm
A 850900SS	Stainless Steel	70kg	80-90 diners	690 x 660 x 1030mm	580 x 467mm
850900B	Black	70kg	80-90 diners	690 x 660 x 1030mm	580 x 467mm
851400SS	Stainless Steel	100kg	130-140 diners	870 x 860 x 1150mm	766 x 648mm
B 851400B	Black	100kg	130-140 diners	870 x 860 x 1150mm	766 x 648mm

Various Stand Options Available
Full Kit Provided for Each Model

FOR FULL RANGE AVAILABLE
VISIT FEM.CO.UK



Stainless Steel Hot Plates

Stainless Steel Hot Plates Keep food warm before service with the new charcoal oven hot plates.

CODE	DESCRIPTION	USE WITH
850508	Stainless Steel Hot Plate	85050SS
850908	Stainless Steel Hot Plate	85090SS
851408	Stainless Steel Hot Plate	85140SS



MAGFLAM Gas Spit Rotisseries



OPTIONAL STAND
ONLY AVAILABLE MAGFLAM 8

The old-time rotisserie oven, hand-crafted, in all its glory...

- Cooking using “Radiating Cast Iron”, with high yield “Live Flame” projectors, provides the look of open fire cooking.
- High-quality stainless steel and enamel construction with refracting blocks and panels that highlight the warm, authentic look of old-time cooking.
- Front panel with backlit “Rôtisserie” inscription, two water-proof glass-ceramic lights and silver-plated tap handles.
- Heat protection with toughened glass windows, “big red” emergency stop button, glass door handles insulated, and hinges fitted with an “open window” locking system.
- The interior can be fully dismantled, and the inside corners are rounded.
- iRegul Control internal programme achieves energy savings of up to 40%, all electrical components have been designed specifically to consume less energy.
- Spring-mounted motor concealment panels (to stop fat from entering the housing), plus lower fat tray with drainage faucet.

MAGFLAM Gas Spit Rotisseries

CODE	W X D X H	SPITS	CHICKENS/HR	PLUG	GAS
MAGFLAM 3N	1100 x 690 x 950mm	3	12 – 15	13A	17.3kw
MAGFLAM 5	1480 x 690 x 1310mm	5	30 – 35	13A	34.6kw
MAGFLAM 5N	1100 x 690 x 1310mm	5	15 – 20	13A	34.6kw
MAGFLAM 8	1480 x 690 x 1850mm	8	48 – 56	13A	51.9kw

Steambox Electric Self-Cleaning Basket Rotisserie



SLEEK TOUCHSCREEN
GLASS CONTROL PANEL



AUTOMATIC STEAM-
CLEANING SYSTEM

Easy cleaning, every time.

A compact rotisserie for an optimum roast.

- Incomparable cooking results thanks to a combination of fan-assisted hot air (for a tender product) and direct infra-red heat (for colour and crispy skin).
- Revolutionary automatic steam-cleaning system takes only 15 minutes to complete.
- Interior can be easily dismantled prior to steam-cleaning.
- Sleek touchscreen glass control panel with digital thermostat and “temperature hold mode”.
- View product from front and back windows with quartz lighting protected by glass ceramic.
- Automatic shut-off once the product is cooked.
- Optional mobile trolley and storage cabinet.



Steambox Electric Self-Cleaning Basket Rotisserie

CODE	W X D X H	BASKETS	CHICKENS/HR	ELECTRIC	PLUG
STEAMBOX	860 x 775 x 890mm	4	12 – 16	9kw (3PH)	16A

Heated Storage Cabinet

CODE	POWER
SB OVEN	2.3kw





MODEL Electric Self-Cleaning Basket Rotisserie

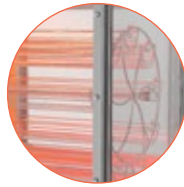

PANORAMIC VISION ON ALL 3 SIDES



AUTOMATIC STEAM-CLEANING SYSTEM

The new panoramic view rotisserie oven with easy cleaning.

- Cooking by multidirectional ventilated infrared and forced hot air make it possible to combine both tender and crispy product results.
- Panoramic vision on all 3 sides gives a timeless and eye-catching design.
- A new anti-reflective and extra-flat digital control panel, which can be positioned on the right or left.
- Revolutionary automatic steam-cleaning system takes only 15 minutes to complete.
- Achieve nearly 30% energy savings and increase profitability with the integrated thermostatic control programme.



Model Electric Self-Cleaning Basket Rotisserie

CODE	W X D X H	BASKETS	CHICKENS/HR	ELECTRIC	PLUG
MODEL 6	1046 x 779 x 909mm	6	20 – 30	9.5kw (3PH)	16A
MODEL 9	1038 x 960 x 1095mm	9	30 – 45	13.5kw (3PH)	32A

Heated Storage Cabinet

CODE	POWER	PLUG
ES6 OVEN	3.3kw	16A
ES9 OVEN	3.3kw	16A

IDéal Electric Advanced Self-Cleaning Basket Rotisserie



The first intelligent rotisserie designed for demanding professionals.

- Optimised performance produces chicken that is perfectly golden on the outside and tender on the inside.
- Innovative closed-loop, 100% cleaning technology is efficient and eco-friendly, with no external discharge.
- Cleaning cycle only consumes 20 litres of water per cycle.
- Sleek panoramic design with large glass surfaces on three sides.
- User friendly operation guide – no technical expertise required.
- Interactive front-panel diagnostics for quick troubleshooting.
- Double-glazed glass to prevent burns and door opening sensor for added security.
- Versatile multifunction cooking capabilities and intuitive touch panel.



IDéal Electric Advanced Self-Cleaning Basket Rotisserie

CODE	W X D X H	BASKETS	CHICKENS/HR	ELECTRIC	PLUG
IDEAL 6	1197 x 944 x 1127mm	6	18 – 24	9kw (3PH)	16A

Storage Cabinet

CODE	DESCRIPTION
AC38	W/ Swivel Castors



Manual 1000W Microwave

- Easy to use with fixed power.
- 6-minute mechanical timer.
- Stainless steel cavity without glass plate.
- Inner dimensions 340 x 340 x 200mm.

Manual 1000W Microwave

CODE	CAPACITY	POWER	PLUG	W X D X H
158122	25L	1kw	 13A	510 x 430 x 310mm



new

Programmable 1000W Microwave

- 5 power levels.
- Practical touch control.
- 60-minute digital timer.
- Stainless steel cavity without glass plate.
- 100 customisable cooking programmes.
- Inner dimensions 340 x 340 x 200mm.

Programmable 1000W Microwave

CODE	CAPACITY	POWER	PLUG	W X D X H
158121	25L	1kw	 13A	510 x 430 x 310mm



TopWave 1800W Microwave

- Powerful output of 1.8kw.
- Generous chamber capacity means two large dishes can be cooked simultaneously.
- One removable shelf.
- Contains two magnetrons, one up and one down. The user can decide to use a single magnetron for saving energy or both for saving time.
- Save up to 10 multi stage cooking programs (up to three stages each).
- Inner dimensions 374 x 378 x 224mm

TopWave 1800W Microwave

CODE	CAPACITY	POWER	PLUG	W X D X H
TW1800	30L	2.8kw	 16A	637 x 490 x 405mm



Induction Countertop Fryer

- Stainless steel structure and handy tap for oil removal.
- Quick heating and easy to clean.
- Splash-proof touch controls.
- Temperature regulation up to 190°C.
- Digital display with Timer easily set up to 120 minutes.
- Alarm reminder to check oil level.
- Oil overheat protection.
- Automatically shuts down if unused.

Induction Countertop Fryer

CODE	POWER	PLUG	W X D X H
KLONDIKE 8R	3.5kw	 16A	290 x 440 x 407mm



new



INCLUDES FRY BASKET AND LID

IP PRO Induction Hobs



COOKING EQUIPMENT

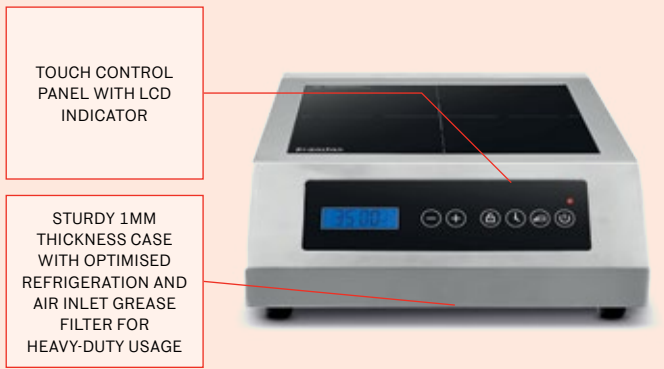

20 POWER LEVELS **50-240°C** TEMPERATURE RANGE **24 h** TIMER **HEAVY-DUTY USAGE**



IP PRO Induction Hobs

CODE	MAX Ø	POWER	PLUG	WXDXH
157921-UK	330mm	3kw	13A	400 x 530 x 150mm
157922-UK	280mm	3kw	13A	340 x 430 x 120mm

IP PRO Drop-In Induction Hob

CODE	MAX Ø	POWER	PLUG	WXDXH
157926	280mm	3.5kw	16A	340 x 360 x 110mm

IP FIRST Induction Hobs

- 13 power levels.
- Temperature range 60-240°C.
- LED touch control with 0-180 minute timer.
- Stainless steel case.



IP PRO Induction Wok

CODE	MAX Ø	POWER	PLUG	WXDXH
157923	360-400mm	3.5kw	16A	340 x 430 x 140mm



Programmable Induction Hob

CODE	MAX Ø	POWER	PLUG	WXDXH
157927-UK	280mm	3kw	13A	340 x 430 x 120mm



Mirage Induction Hob

- Cutting-edge dial control with High-speed power and temperature level adjustment – includes 1-180 minute timer function.
- Bright LED digital readout is easy to see.
- Temperature memory powers up to the last used temperature setting.
- Smart component placement means cord and fans are located under the top case assembly, improving appearance.
- Tough stainless steel case with 100% framed ceramic top for durability.



Mirage Induction Hob

CODE	DESCRIPTION	POWER	PLUG	W X D X H
A 59651	Countertop hob	1.8kw	13A	356 x 387 x 76mm
B 59602	Drop-in hob	1.8kw	13A	368 x 318 x 73mm

Professional Series Induction Hobs

- 100 settings for precise cooking control—set to power level or temperature setting.
- Continuous duty induction circuitry for non-stop cooking.
- Firewall protected circuitry with oversized fans and 18 gauge heavy-duty 18-8 stainless steel casing.
- 1-180 minute timer—unit shuts off at end of cycle.
- Digital display is easy to clean—no knobs to collect food and it helps prevent accidental temperature changes.
- "HOT" warning display for safety.



Professional Series Induction Hobs Countertop

CODE	DESCRIPTION	POWER	PLUG	W X D X H
6954303NGCT	Single	2.6kw	13A	419 x 327 x 102mm
C 6954703	Double	3.8kw	16A	330 x 686 x 127mm

Induction Fajita Skillet Heater

- Simple one-touch operation produces perfect results in record time, every time.
- Works with the two standard fajita pan styles.
- Heat room temperature pans to proper sizzle temperatures, not designed to directly cook food.
- Two time and temperature presets.



HEATS CAST IRON PANS,
SOLD SEPARATELY

Induction Fajita Skillet Heater

CODE	DESCRIPTION	POWER	PLUG	W X D X H
6954303NGCT-F	Single	2.6kw	13A	419 x 327 x 102mm



4-Series Countertop Induction Hob with Temperature Control Probe

- Expanded magnetic field emulates gas to allow uninterrupted heat while lifting or tilting pan to sauté or flip.
- Steady, controlled heating in single degree increments from 27°C to 232°C.
- Power level control offers responsive gas flame-like control, in increments from 1 to 100% of watts. Use for fast, powerful heating.
- No power cycling: Patented circuitry delivers steady heat.
- Timer with audible alarm: Heating stops when time expires.
- Sleek, stainless steel case with non-slip, durable feet.
- Included Temperature Control Probe provides additional temperature accuracy.



4-Series Countertop Induction Hob with Temperature Control Probe

CODE	POWER	PLUG	W X D X H
HP14-260003	2.6kw	13A	420 x 492 x 133mm
HP14-300003	3kw	13A	420 x 492 x 133mm
HP14-380003	3.8kw	16A	420 x 492 x 133mm

Floor Standing Double Induction Hob



- Practical and space-saving hob features a double heating plate with two induction units.
- LED display with separate touch controls for both hobs.
- Temperature and cooking times can be easily set.
- The unit switches off automatically after two hours if not used.
- The generously sized bottom compartment has ample space for accessories.
- Temperature 60°C to 240°C.

Floor Standing Double Induction Hob

CODE	DESCRIPTION	POWER	PLUG	W X D X H
IH 35X2 70	700mm Deep	3.5kw x 2 (3PH)	32A	400 x 700 x 980mm
IH 5X2 90	900mm Deep	5kw x 2 (3PH)	32A	400 x 900 x 980mm



High-Speed MultiFlex Clamshell Grill



The MultiFlex's versatility is best shown by the 'top heater off' feature allowing a flat surface griddle function. Meal changeover is as simple as switching on the top heater, allowing top surface grilling to create foods like paninis, BLTs, grilled cheese sandwiches and more.

- Suitable for cooking protein.
- Top heater temperatures are independent for product flexibility.
- Top heaters are parallel with the bottom grill surface to perfectly grill thick sandwiches.
- Top heaters can be turned off to use the bottom plate as a flat grill.
- Heavy-duty torsion spring.
- A catch tray and the elimination of hidden grooves and crevices make cleaning and maintenance simple.
- Flat, aluminium plates as standard.
- All models available to order with ribbed or ribbed/flat plates.



COOKING EQUIPMENT



FLAT SINGLE PLATES



FLAT SINGLE PLATES



FLAT DOUBLE PLATES

NCG8-F Clamshell Grill 2.8kw

CODE	DESCRIPTION
NCG8-F	293 x 558 x 677mm
600-001S	NCG8 Teflon Sheet Kit

NCG9-F Clamshell Grill 2.8kw

CODE	DESCRIPTION
NCG9-F	320 x 470 x 559mm
600-002S	NCG9 Teflon Sheet Kit

NCG14-F Clamshell Grill 2.8kw

CODE	DESCRIPTION
NCG14-F	442 x 588 x 677mm
600-003S	NCG14 Teflon Sheet Kit

*ALL MODELS SUPPLIED WITH 13A PLUG.

Ceramic Panini Grill

The PDVC ceramic panini grill is the preferred choice for major coffee chains...

- Uses approximately 35% less energy than a conventional Panini grill.
- Stainless steel construction.
- Ceran® ceramic glass cooking surfaces.
- Thermostat control.
- Useful drip tray for liquids and other cooking leavings.
- Easy to clean.
- Adjustable feet for a safe and steady placing.
- Ideal for a fast achievement of working temperature.



Ceramic Panini Grill

CODE	DESCRIPTION	POWER	PLUG	COOKING AREA	W x D x H
PDVC RR T	Ribbed	3kw	13A	530 x 255mm	592 x 441 x 166mm
PDVC LR T	Flat/Ribbed	3kw	13A	530 x 255mm	592 x 441 x 166mm

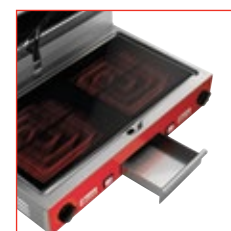

**SAVE OVER
£400 PER YEAR
IN ENERGY
COSTS!**

Contact Grills



SIRMAN PANINONSTICK® Contact Grills

Featuring an exclusive ceramic coating treatment on cooking surfaces. Non-stick, no peel, no chip ceramic coated cast iron surfaces for hassle-free cleaning.

- Ideal for high volume operations including cafes, bars, restaurants, kiosks, delis and supermarkets.
- Ribbed, Flat, and Flat/Ribbed surfaces available.
- Adjustable thermostat up to 300°C (PD models have 2 independent plates).
- Cast iron plates with ceramic coating treatment ensure easy cleaning and reduce cooking time.
- Self-balancing upper plates automatically adjust to the thickness of the product and stay in place.
- Heavy-duty stainless steel construction.
- Timer fitted with all models.

Single – Elio

CODE	DESCRIPTION	POWER	PLUG	COOKING AREA	W x D x H
ELIO RR T	Ribbed	1.55kw	13A	250 x 255mm	260 x 435 x 235mm
ELIO LR T	Flat/Ribbed	1.55kw	13A	250 x 255mm	260 x 435 x 235mm



ELIO

Large Single – Cort

CODE	DESCRIPTION	POWER	PLUG	COOKING AREA	W x D x H
CORT LL T	Flat	2.1kw	13A	355 x 255mm	380 x 435 x 235mm
CORT RR T	Ribbed	2.1kw	13A	355 x 255mm	380 x 435 x 235mm
CORT LR T	Flat/Ribbed	2.1kw	13A	355 x 255mm	380 x 435 x 235mm



CORT

Double – PD

CODE	DESCRIPTION	POWER	PLUG	COOKING AREA	W x D x H
PD LL-LL T	Flat	3kw	13A	500 x 255mm	515 x 435 x 235mm
PD RR-RR T	Ribbed	3kw	13A	500 x 255mm	515 x 435 x 235mm
PD LR-LR T	Flat/Ribbed	3kw	13A	500 x 255mm	515 x 435 x 235mm



PD

Conveyor Toasters



300 SLICES PER HOUR

- Ideal for busy catering establishments and hotels with an output of 300 slices per hour.
- Easy load rack with 2 slice feed.
- Front or rear output chute option - for back of house use.
- Toast Selector switch for Bread, Buns or Off.
- Variable toasting colour control.
- Easy fit and removable crumb trays for fast cleaning.
- High-quality stainless steel finish.

Conveyor Toaster

CODE	POWER	PLUG	DESCRIPTION	W x D x H
FT1	2.4kw	13A	2 Slice	368 x 418 x 387mm



800 SLICES PER HOUR



1,100 SLICES PER HOUR

- Forced convection toasting promotes uniform results and energy efficiency.
- Energy efficient, fast reacting, quartz heaters.
- Standby mode saves up to 75 percent energy during slow periods when unit is not in use and allows unit to quickly return to full power.
- Variable speed control to achieve desired colour.
- Stainless steel and aluminized steel construction.
- High-temperature bearings ensure smooth operation and do not require lubrication.
- High-quality, insulated wires help prevent against dry rotting and cracking.
- CT4-230DUAL - Top chamber product entry opening is adjustable from 3.8 - 7.6cm, bottom chamber entry opening is adjustable up to 3.8cm.



1,000 SLICES PER HOUR

Energy Saving Conveyor Toaster

CODE	POWER	PLUG	DESCRIP.	W x D x H
A CT4-2308003	2.8kw	13A	2 slice	359 x 603 x 356mm
B CT4-2301000	3.6kw	16A	3 slice	458 x 603 x 356mm
C CT4-230DUAL	4.9kw	32A	4 slice	514 x 730 x 597mm

Conveyor Sandwich Ovens



1,000 SANDWICHES PER HOUR



1,200 SANDWICHES PER HOUR



- Adjustable 38 – 76mm product opening for added heat control.
- Infinite top and bottom heat controls.
- Extended conveyor (front and rear) for pass-through convenience.
- Variable speed control allows for real-time adjustments.
- Forced convection toasting promotes uniform results and energy efficiency.
- Energy-efficient, fast-reacting, quartz heaters.
- Industry's only maintenance-free drive system; stainless steel drive chain does not require lubrication.
- Intended for operations with a low volume of toasted sandwiches or are looking to add them to the menu.

Conveyor Sandwich Ovens

CODE	BELT WIDTH	POWER	PLUG	W x D x H
S02-230105	267mm	2.8kw	13A	409 x 338 x 318mm
S02-230145	368mm	3.6kw	16A	511 x 389 x 318mm



Vertical Contact Toaster



- Toasting for high volume operations.
- Great choice for toasting buns for burgers and sandwiches 'on demand'.
- Delivers higher toasting capacities while maintaining proven reliable design.
- Stronger motor and higher temperature platen increases performance.
- Two-level platen evenly caramelises up to 5.5" (14cm) breads.
- Adjustable bun crush controls and thermostat allow precise toasting.
- Caramelises the buns, forming a coating that protects the buns from juices and condiments that can cause soggy, unattractive buns.
- Compact design requires only 203mm of counter space depth.

Vertical Contact Toasters All models rated 1.7kw.

CODE	BUNS P.H.	POWER	TIMER	W x D x H
297-T9FGB	2,400	1.7kw	9 second	635 x 208 x 668mm
297-T14FGB	2,400	1.7kw	14 second	635 x 208 x 668mm
297-260	Toaster Release Sheets Pack of 2			
511	Optional Top Mounting Bun Dresser			

Slimline Vertical Contact Toaster



- Slimline design saves up to 30% more counter space.
- Adjustable toast times from 9-40 seconds to customise products.
- Digital display with easy-to-use interface - one-touch LCD screen for seamless operation.
- Simple to remove conveyor makes cleaning quick and easy.
- Dual compression adjustment knobs allow for maximum product flexibility.
- Accommodates buns up to 5.5" (14cm) in diameter.
- Heat shield for cooler surfaces ensuring safer operation.
- Advanced heating technology ensures precision toasting and reduces waste during peak demand.
- Consistent results across a wide variety of bread types maintain customer satisfaction.

Slimline Vertical Contact Toaster Wire belt as standard.

CODE	BUNS P.H.	POWER	TIMER	W x D x H
CTS-WCE	1,200	1.5kw	9-40 Second	514 x 165 x 564mm

Toaster release sheets and butter wheel available.

Vertical Dual-Sided Contact Toaster



- A revolutionary design that increases the versatility of toasting, maximises space-saving and provides perfect caramelisation with the convenience of vertical toasting.
- Large Touch Screen with LCD display for easy programming.
- Patented Parallel Compression Design increases toasting speed and surface contact for better caramelisation.
- Digital programming for variable toast time and temperature settings.
- Auxiliary heater option available for higher bun temperatures.
- Stainless steel construction with Anti-slip rubber base.
- Designed for peak efficiency, it can handle two bread pieces simultaneously thanks to its dual-lane design concept, cutting service time in half without compromising on quality.

Vertical Dual-Sided Contact Toaster Single and double lane models available with different belt options.

CODE	BUNS P.H.	POWER	LANES	W x D x H
A CTD-SAX-CE	1,200	1.65kw	Single	305 x 274 x 541mm
B CTDE-WAX-CE	2,400	3kw	Double	444 x 274 x 541mm

Toaster release sheets and butter wheel available for both models.

*ALL CONTACT TOASTER MODELS SUPPLIED WITH 13A PLUG.

Batch Bun Toaster



- Toasts up to 12 complete buns at one time.
- Provides perfect caramelisation by contact toasting for better tasting product and prevents condiments from saturating buns.
- Unit is easy to clean and maintain.
- Visible and audible alarms signal toast cycle is complete.
- Adjustable thermostat provides precise toasting for all types of bread products.
- Adjustable bun thickness controls.
- Adjustable timer from 20-100 seconds.
- Stainless steel and aluminium construction.
- Durable nickle-plated heating platen provides uniform heat.
- Includes 1 spatula.

Batch Bun Toaster

CODE	POWER	PLUG	W x D x H
212-AC	2.3kw	 13A	698 x 406 x 295mm

Egg Cooker



- Deliver perfectly shaped, great tasting eggs with ease and conformity in less than 3 minutes.
- Cook up to 6 eggs per cycle.
- Compact design limits use of counter space.
- Electrical temperature control provides more consistent temperature and cooking.
- Non-stick egg ring features a detachable design for easy cleaning.
- Robust stainless steel for long-term durability.

Egg Cooker

CODE	POWER	PLUG	W x D x H
EC6-RDCE	2.5kw	 13A	458 x 441 x 234mm

Rice Cooker / Warmer



- Insulated, double-wall stainless steel construction holds in heat to keep contents warm and moist for hours.
- Cooks rice, grits, oatmeal and mac and cheese.
- Large capacity single batch cooking.
- Automatically shifts to warm mode when cooking has finished.
- Trigger handle: press button and lift to open.
- Heated lid ensures even cooking.
- Removable-non-stick inner pot for easy clean up.
- Includes 600ml measuring cup and serving spatula.
- 60 Cup rice cooker can hold 14L of cooked rice per sitting.

Rice Cooker/Warmer

CODE	CAPACITY	POWER	PLUG	W X D X H
37560R-UK	14L	1.95kw	 13A	460 x 460 x 390mm



Sous Vide Immersion Circulator



PAIR WITH PRIMAVAC™
VACUUM PACKERS
SEE PAGE 23



- 1.2kw pump keeps up to 30L of water at an even, consistent temperature.
- Heats up to 95°C.
- IPX7 construction prevents malfunction if accidentally dropped in water.
- Adjustable timer lets you select up to 99 hours.
- Displays temperature in tenths of a degree.
- Easy-to-read display and touchpad controls.
- Audible alert and auto-shutoff if water level is too high or low.
- Cleaning cycle and reminder.

Sous Vide Immersion Circulator

CODE	POWER	CAPACITY	W x D x H
HSV1000-UK	1.2kw	30L	89 x 190 x 324mm

SOFTCOOKER Sous Vide System



WITH WIFI CAPABILITIES
AND OPTIONAL
WIRELESS PROBES



- The SOFTCOOKER system enables consistent temperature control throughout the whole container at all times.
- No hot or cold spots.
- A large and practical 5" touchscreen display, with IP 67 rating.
- Up to 10 instant programmes on the machine and countless other programmes through the mobile APP.
- APP means you can check cooking progress anywhere at any time.
- Practical and robust wireless probes (optional) with NFC technology allow you to read the internal product temperature.
- Optional wireless probes can be reused thousands of times and loaded with data regarding the product, cooking, packaging date etc.

SOFTCOOKER Sous Vide System

CODE	DESCRIPTION	POWER	W X D X H
SOFTCOOKER WI- Sous Vide FOOD X NFC		2kw	165 x 203 x 377mm
69460000	Wireless Probes (6 pack)		
69062000	1/1 GN Stainless Steel Container with Lid		
69062500	2/1 GN Stainless Steel Container with Lid		



Sous Vide Water Baths



A



B

- Low-temperature cooking device with water static heating.
- Stainless steel structure and 1/1 or 2/3 GN made of heavy-duty stainless steel.
- Practical handles for easy carrying.
- Powerful shock-proof coated heating elements in contact with the tank bottom.
- Electronic control system of temperature with working temperature display.
- 5 storable programmes.
- Comes with drain and lid.

Sous Vide Water Baths

CODE	DESCR	POWER	CAP	W X D X H
A	SOFTCOOKER 2/3	2/3 GN	1.1kw	14L 423 x 368 x 309mm
B	SOFTCOOKER 1/1	1/1 GN	1.7kw	22L 595 x 368 x 309mm

*ALL SOUS VIDE MODELS SUPPLIED WITH 13A PLUG.



VACUUM PACKERS
SEE PAGE 24



Featured Brands

ALTO SHAAM

PRINCECASTLE

pujadas
A VOLLRATH COMPANY

SERVER

SIRMAN

VOLLRATH

Heating & Holding

High-volume and quick service operations rely on holding cooked food ready for immediate service...without compromising quality. Customers want speed, but never at the expense of taste or appearance. Designed to maintain flavour, texture, and presentation for longer, our heated holding equipment keeps food at its best until it's served, ensuring consistent quality and satisfied customers.



Dedicated Holding Bins	80
Extended Holding Bins	81
Drawer Warmers	82
Heated Holding Cabinets	84
Heated Banquet Carts	85
Heated Holding Trolleys	86
Hot Food Wells	86
Carving Stations	87
Hanging Heat Shades	88
Countertop Heat Shades	89
Induction Warmers	90
Food Warmers	91
Heated Merchandisers	92
Soup Kettles & Rethermalisers	93

Prince Castle Holding Bins The Benefits...

Store food longer with solutions tailored to the ideal temperature and humidity.

- Improve food quality with customised temperatures that eliminate drying-out.
- Hold food at safe temperatures for longer than other methods – over 1 hour without loss of flavour, texture or shrinkage.
- Less waste, faster speed of service and increased operational flexibility.
- Hold both fried and grilled menu items in the same bin.

Features: Differentiating food holding with solutions that make sense.

- MenuTrak technology offers operators the ability to supervise held products by assigning where menu item components are located and monitoring hold times.
- Point-of-use product access limits heat loss while ensuring freshness of remaining products.
- Easy-access operations streamline serving and simplify clean-up for a condensed dispersion time.
- Exclusive Reli-A-Temp™ infrared heater technology provides consistent food temperatures.



Dedicated Holding Bins

- Improved speed of service and product consistency.
- Independent upper and lower heating system per cavity.
- Alphanumeric display makes it easy to read item descriptions.
- Single-sided digital controls.



Dedicated Holding Bins includes 65mm deep 'high temp' pans. DHB2PT-20PUB includes 1 x 65mm deep 'high temp' pan and 1 x 100mm deep 'high temp' pan.

CODE	DESCRIPTION	POWER	W x D x H
A DHB2PT-20PUB	2 x 1/1 GN Pans	1.9kw	484 x 610 x 340mm
B DHB2PT-GMCN	2 x 1/1 GN Pans	1.7kw	460 x 520 x 245mm
C DHB3PT-GMCN	3 x 1/1 GN Pans	2.5kw	460 x 520 x 338mm

*ALL MODELS SUPPLIED WITH 13A PLUG.



STACKABLE
TWO DHB2PT-20PUB
HOLDING BINS STACKED





Extended Holding Bins with MenuTrak

Double your food's hold times safely, with patented dual-zone temperature control technology from Prince Castle. Whether it's crispy chicken or juicy burgers, you can now hold your food twice as long without sacrificing quality or flavour.

Patented multi-zone temperature controls

keep fried foods crispy and cooked foods tender.

2X hold times

with proprietary dual-zone temperature controls.



Removable metal lids

enhance heat conduction while maintaining quality, texture, temperature and taste.

Timers by each pan

indicate when to cook more and ensure first in first out.



Preserve Food Quality and Reduce Waste

- Double your food's hold times with our patented multi-zone temperature controls, creating the perfect holding environment for each food type.
- Multi-zone temperature controls create the perfect holding environment for each food type.
- Ensure first in first out method with centrally located timer bars, eliminating food waste.
- Never run out of food during peak rush hours with cook more alerts.

All Day Menu Flexibility

- Keep your cooked foods tender with metal lids or your fried foods crispy with no lids.
- 6-day parts, 25 menu pre-sets.
- Easy-to-update recipe names, heater temps, cook times and day parts.
- USB port included for easy upload of new menus.

Durable Construction

- Minimise grease and heat migration with durable stainless steel construction.
- Enjoy longer product life cycles with an independently sheltered control board.
- Sturdy metal lids and pans included.
- Single-sided and pass-through options available for efficient operations.

Easy To Clean

- Rackless design is easy to clean and maintain with a simple daily wipe-down.
- No difficult-to-clean crevasses or corners.
- Easy troubleshooting and servicing with error codes.

Single-Sided Extended Holding Bins

CODE	DESCRIPTION	POWER	PLUG	WXDXH
D EHB22CE	4 x 1/3 GN Pans	0.8 - 1.05kw	13A	500 x 358 x 290mm
EHB23CE	6 x 1/3 GN Pans	1.3 - 1.9kw	13A	691 x 358 x 290mm
E EHB42CE	8 x 1/3 GN Pans	1.6 - 2.1kw	13A	500 x 358 x 523mm
EHB24CE	8 x 1/3 GN Pans	1.87 - 2.5kw	13A	843 x 358 x 290mm
F EHB34CE	12 x 1/3 GN Pans	2.6 - 3.9kw	32A	843 x 358 x 460mm

Double-Sided Extended Holding Bins

CODE	PLUG
EHB22ACE	13A
EHB23ACE	13A
EHB42ACE	13A
EHB24ACE	13A
EHB34ACE	32A

Heated Holding

Alto-Shaam Heated Holding Advantages

- **HALO HEAT** The key to quality holding is to preserve as much natural product moisture as possible and that's exactly what the gentle holding capability of Halo Heat is designed to accomplish.
- **No added humidity** Adding steam to held foods waters down taste and can overcook food. None of Alto-Shaam's Heated Holding products use water vapour to maintain temperature or moisture.
- **No drying out** Another culprit in robbing food of flavour is convection fans. Even though it's circulating warm air, it's also drying out your food at the same time.
- **Precise heat management** The soft-gentle Halo Heat heats food gently and consistently, from top to bottom, for hours at a time.



Hold on to your money, too!

Alto-Shaam Heated Holding products not only maintain your food quality, but they also help maintain your bottom line!

- **Low energy usage** Most of Alto-Shaam's Heated Holding Cabinets are ENERGY STAR rated, which means they use less than 40 watts per square foot.
- **Longer food holding and better food quality** Food kept in Alto-Shaam Heated Holding equipment stays fresh and ready-to-serve longer, reducing your food shrink and helping out your bottom line.
- **Take control of your schedule** Cook production items during off-peak times and hold them in our equipment. Plan an entire banquet and hold the panned or plated food until you're ready to serve.
- **No water usage** None of our heated holding equipment uses a drop of added water. You can put that savings right to your bottom line.



A variety of heated holding systems

Whether you're holding small production items, a complete banquet, or something in between, Alto-Shaam has a heated holding answer for you...

Drawer Warmer with Individual Controls

- Individual controls for each drawer allows food to be held at the optimal temperature.
- Sealed, static holding environment traps natural flavour and juices, reducing shrink, improving food quality and extending hold life.
- Maintain food quality. Keep product at its perfect serving temperature and hold for hours without overcooking or drying out.
- Easy to operate. Adjustable, electronic thermostat with digital display monitors the inside temperature to ensure food is being held at safe and precise temperatures.
- Easy to clean. Simply remove shelves and wipe clean.
- Greater yields and less food waste with Halo Heat technology.
- Expand menus, reduce prep time and labour costs.
- Drawers can be mounted on casters for easy mobility.
- Build onto cabinets or counters, or stack to further maximise space.



**WATERLESS
DESIGN. REDUCE
INSTALLATION AND
OPERATING COSTS**



Two Drawer

CODE	DESCRIPTION	CAPACITY	PAN CAPACITY	POWER	W X D X H
500-2DI	Wide	2 x 16kg	2 x 1/1 GN D150mm	0.59kw	624 x 657 x 491mm

*ALL MODELS SUPPLIED WITH  13A PLUG.

Drawer Warmers



- Alto-Shaam drawer warmers can fit anywhere you need production items held hot and within reach.
- Available in one-, two- or three- drawer configurations, both in standard and narrow widths.
- HALO HEAT offers a controlled, uniform heat source that gently surrounds foods for better appearance, taste, and longer holding life.
- Product moisture is retained without adding water.

- Holding temperature gauge monitors inside air temperature.
- ON/OFF adjustable thermostat with a range of 16° to 93°C.
- Can be built into cabinets or counters. Built-in trim kits are available.
- Stackable design.
- Drawer warmers come complete with standard pans. Oversize pans available.
- Drawers come vented as standard.
- Optional mobile dollies available for 2 and 3 drawer models.



ALL MODELS SUPPLIED WITH VENTED DRAWERS

LARGE CAPACITY EACH DRAWER COMPARTMENT CAN HOLD 34 POTATOES OR 50 BREAD ROLLS.



SHOWN AS A BUILT-IN UNIT USING OPTIONAL TRIM KIT

OPTIONAL BUILT-IN TRIM KITS

Single Drawer Factory options POA.

CODE	DESCRIPTION	CAPACITY	PAN CAPACITY	POWER	W X D X H
A 500-1D	Wide	1 x 16kg	1 x 1/1 GN D150mm	0.59kw	624 x 657 x 296mm
500-1DN	Narrow	1 x 16kg	1 x 1/1 GN D150mm	0.59kw	423 x 792 x 296mm

Two Drawer Factory options POA.

CODE	DESCRIPTION	CAPACITY	PAN CAPACITY	POWER	W X D X H
500-2D	Wide	2 x 16kg	2 x 1/1 GN D150mm	0.59kw	624 x 657 x 481mm
B 500-2DN	Narrow	2 x 16kg	2 x 1/1 GN D150mm	0.59kw	423 x 792 x 481mm

Three Drawer Factory options POA.

CODE	DESCRIPTION	CAPACITY	PAN CAPACITY	POWER	W X D X H
C 500-3D	Wide	3 x 16kg	3 x 1/1 GN D150mm	0.59kw	624 x 657 x 664mm
500-3DN	Narrow	3 x 16kg	3 x 1/1 GN D150mm	0.59kw	423 x 792 x 664mm

*ALL MODELS SUPPLIED WITH 13A PLUG.

Drawer Warmer Mobile Dollies

CODE	DESCRIPTION
500-D DOLLY	Fits 500-2D, 500-2DI & 500-3D
500-DN DOLLY	Fits 500-2DN & 500-3DN

Heated Holding Cabinets



- HALO HEAT is a controlled, uniform heat source that gently surrounds food for better appearance, taste, and longer holding life.
- Close temperature tolerance and even heat application maintain ideal serving temperatures throughout the cabinet.
- Holds all types of food - meats, poultry, potatoes, fish, vegetables, and casseroles - fresh, flavourful and hot.
- ON/OFF adjustable thermostat with a range of 16° to 93°C.
- Holding temperature gauge monitors inside air temperature.
- Fully insulated and concealed electrical components.

- Stainless steel interior resists corrosion.
- Castors provide easy mobility.
- Can be stacked with an identical unit or cook/hold oven to save space.
- The straightforward Manual control uses arrow keys for push-button temperature settings, a digital display, and an intuitive design to make operation easier.
- Optional solid-state electronic control option simplifies temperature setting, has a clear, easy-to-read LED display, and includes SureTemp-heat recovery system.
- Further electronic options available include six independent multiple timers or an internal temperature probe.



A



B



C



D

300-S includes

- 2 stainless steel side racks.
- 1 set of non-skid rubber feet.
- 4 carrying handles.
- 19mm non-skid feet.

500-S & 750-S includes

- 2 stainless side racks.
- 2 chrome wire shelves.
- 64mm castors.

1200-S/SR includes

- 2 stainless side racks.
- 3 chrome wire shelves.
- 127mm castors.

1200-UP/SR includes

- 4 stainless side racks.
- 6 chrome wire shelves.
- 127mm castors.

Heated Holding Cabinets Right-hand hinge as standard. Factory options POA.

CODE	PRODUCT CAPACITY	PAN CAPACITY	POWER	W X D X H
A 300-S	16kg (36lbs)	3 x 1/1 GN D65mm	0.8kw	443 x 645 x 466mm
500-S	18kg (40lb)	6 x 1/1 GN D 65mm	0.95kw	483 x 675 x 809mm
B 750-S	45kg (100lb)	10 x 1/1 GN D 65mm	1kw	676 x 797 x 809mm
1000-S	54kg (120lb)	8 x Sheet Pans (450x650mm)	0.9kw	597 x 801 x 1025mm
C 1200-S/SR	87kg (192lb)	16 x 1/1 GN D 65mm	0.9kw	671 x 817 x 1117mm
1000-UP	108kg (238lb)	16 x Sheet Pans (450 x 650mm)	1.8kw	608 x 804 x 1924mm
D 1200-UP/SR	174kg (384lb)	32 x 1/1 GN D 65mm	1.8kw	671 x 817 x 1924mm

FACTORY INSTALLED OPTIONS

Electronic control version, Electronic Multi-timer, Window door, Pass-through design.

ACCESSORIES

Full perimeter bumpers, Carving holders, Door lock with key, Drip pans (internal & external), Shove handle kit, Stacking kit, Shelves & pan supports, Legs.

*ALL MODELS SUPPLIED WITH 13A PLUG.

Heated Banquet Carts



- Alto-Shaam Banquet carts are built to handle your most challenging banquets.
- Holds pre-plated food fresh, flavourful, and hot.
- No moisture pans, water or canned heat needed.
- HALO HEAT is a controlled, uniform heat source that gently surrounds food for better appearance, taste, and longer holding life.
- Close temperature tolerance and even heat application provides even heat from top to bottom – side to side.
- An adjustable, electronic thermostat with digital display monitors the inside temperature to ensure food is being held at safe and precise temperatures.

- Superior insulation ensures the cavity will only lose 2°F for every 45 minutes it is held without power, provided the doors remain closed.
- Designed to adapt to any type of banquet holding:
 - Covered plates, stacked
 - Covered or uncovered plate carriers
 - Accepts trays for banquet service
 - Additional shelves for 1/1 and 1/2 gastronorm pans.
- Non-magnetic stainless steel interior resists corrosion.
- Full perimeter, wall-friendly bumper, transport handles, and heavy-duty castors.



HEATING & HOLDING



A



B



C

Includes

- 4 transport handles.
- 4 chrome wire shelves.
- 4 shelf runners & clips.
- bumper surround.
- 4 x 152mm castors.

Includes

- 4 transport handles.
- 4 chrome wire shelves.
- 4 shelf runners & clips.
- bumper surround.
- 4 x 152mm castors.

Includes

- 4 transport handles.
- 8 chrome wire shelves.
- 8 shelf runners & clips.
- bumper surround.
- 6 x 152mm castors.

Heated Banquet Carts

CODE	PRODUCT CAPACITY	PLATE CAPACITY	POWER	W X D X H
A 1000-BQ2/96	109kg (240lb)	96 x 10" plates w/ cover	1.5kw	954 x 773 x 1714mm
B 1000-BQ2/128	145kg (320lb)	128 x 10" plates w/ cover	2kw	1154 x 773 x 1714mm
C 1000-BQ2/192	218kg (480lb)	192 x 10" plates w/ cover	3kw	1744 x 773 x 1714mm

ACCESSORIES

Uncovered Plate Carrier, Covered Plate Carrier, Plate covers, Shelf supports, Chrome wire shelf, Door lock w/ key.

*ALL MODELS SUPPLIED WITH  13A PLUG.



UNCOVERED



COVERED



Heated Holding Trolleys

- Designed to keep food and dishes warm with high performance and low power consumption that guarantee maximum quality and temperatures above 65°C.
- Unique system makes it impossible for pans to touch the cabinet base or sides, this results in an even and constant circulation of air throughout the unit.
- Trolleys are easy to manoeuvre with back and side handles, rotating wheels that turn 360° and front wheels fitted with brakes.
- Includes thermostat for regulation of temperatures between 0°C and 100°C. Provided with humidification container.
- With the exclusive system of weldless monoblock pan-guides, cleanliness inside is greater, easier and faster.

A



ENERGY SAVING

Thanks to the extraordinary thermal insulation system, the desired temperature is achieved more quickly and the heat is conserved for longer periods.

Heated Holding Trolleys

CODE	PAN CAPACITY	POWER	PLUG	W X D X H
81012	17 x 2/1 GN or 34 x 1/1 GN D65mm	3kw	13A	700 x 810 x 1740mm
A 81022	34 x 2/1 GN or 68 x 1/1 GN D65mm	4kw	16A	1470 x 810 x 1740mm

Hot Food Wells

- Extend food holding times with efficient, precise Halo Heat® technology.
- Maintain food quality without the use of extremely hot elements, added humidity or fans.
- Increase sales with attractive food presentation and quality.
- Save on maintenance costs, eliminating lime and scale build-up associated with traditional steam tables.
- Increase employee and customer safety with the elimination of hot water and steam.
- Provide optimal holding temperatures with an adjustable thermostat that can be flush-mounted into the counter or a location out of sight from customers.
- Set ideal holding temperatures for any dish with an individual well control option.

A SIMPLE ELECTRICAL SOCKET IS ALL YOU NEED, NO WATER, PLUMBING OR WATER RELATED INSTALLATION OR SERVICE COSTS.



Hot Food Wells Available in sizes ranging from a single full-size hotel pan wide, up to five pans wide.

CODE	SHELF CAPACITY	PRODUCT CAPACITY	POWER	PLUG	W X D X H
100-HW/D6	Single pan	1 GN 1/1 Pan (150mm)	0.6kw	13A	380 x 586 x 225mm
200-HW/D6	Two-Pan	2 GN 1/1 Pans (150mm)	1.2kw	13A	712 x 586 x 235mm
300-HW/D6	Three-Pan	3 GN 1/1 Pans (150mm)	1.8kw	13A	1039 x 586 x 234mm
400-HW/D6	Four-Pan	4 GN 1/1 Pans (150mm)	2.4kw	13A	1371 x 586 x 235mm
500-HW/D6	Five-Pan	5 GN 1/1 Pans (150mm)	3.0kw	13A	1702 x 586 x 235mm

Contoured Carving Station

- Attractive Carving Station with lamps for additional heat while serving.
- Heavy-duty steel frame, chrome-plated.
- Stylish solid surface base & top.
- Clear tempered glass customer breath guard.
- Knife-friendly, dishwasher safe NSF Certified cutting board included.
- Spun aluminium shades for heat dissipation.
- Recessed base channels liquids into removable drip pan.

Carving Station

CODE	DESCRIPTION	POWER	W X D X H
46672	Double Lamp	0.25kw	609 x 559 x 685mm

*SUPPLIED WITH  13A PLUG.



Carving Stations

- Add a major attraction to any buffet line with carve-to-order service.
- Designed to keep that succulent roast at peak serving temperature throughout an event.
- Soft, gentle Halo Heat radiates from the recessed carving shelf surface, while fixed lamp assembly provides greater ambient surface temperature control.
- Each shelf is designed to stand alone or can be mounted directly on a Halo Heat Cook & Hold oven or holding cabinet.
- Sneeze guard easily slides out of the way for carving in prep areas and for cleaning.
- Sanitary cutting board with gravy lane completely removable.
- Includes ON/OFF switch with adjustable thermostat.
- Low energy usage.



HALO
HEAT



Carving Stations

CODE	DESCRIPTION	CAPACITY	POWER	W X D X H
CS-100/S	Single Lamp	18kg (40lb)	0.5kw	466 x 657 x 792mm
CS-200/S	Double lamp	32kg (70lb)	0.8kw	660 x 782 x 842mm

*ALL MODELS SUPPLIED WITH  13A PLUG.

Heat Shades

new

- Keep your food warm with this stylish range of contemporary heat lamps available in a wide range of colours and styles!
- Easily adjust to your desired temperature by raising or lowering lamps.
- Long-lasting, durable construction.

Hanging Heat Shades

A Classic Hanging Heat Shade White 250w bulb included.

CODE	DESCRIPTION	COLOUR
156521	Copper	Copper
156522	Aluminium	Matt Aluminium
156523	Aluminium	Anodized Matt Black

B Minimal Hanging Heat Shade White 250w bulb included.

CODE	DESCRIPTION	COLOUR
156524	Stainless Steel	Chrome
156525	Stainless Steel	Copper
156526	Stainless Steel	Matt Black

C Retro Hanging Heat Shade White 250w bulb included.

CODE	DESCRIPTION	COLOUR
156527	Stainless Steel	Chrome
156528	Stainless Steel	Copper
156529	Stainless Steel	Space Grey

D Modern Hanging Heat Shade White 250w bulb included.

CODE	DESCRIPTION	COLOUR
156530	Stainless Steel	Chrome
156531	Stainless Steel	Copper
156532	Stainless Steel	Matt Black

Bulbs

Bulbs

CODE	DESCRIPTION	WATTAGE
15033	Red	175w
710205	Red	250w
15034	White	175w
710206	White	250w



BULBS SUITABLE FOR ALL PUJADAS HEAT SHADES

REQUIRES ELECTRICAL INSTALLATION

Countertop Heat Shades

new

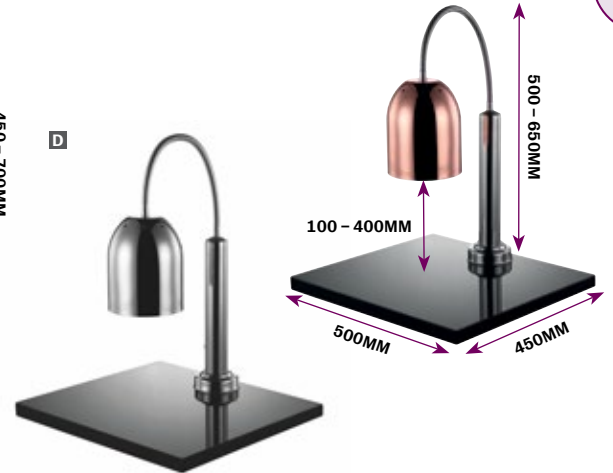

A Heat Lamp with Base White 250w bulb included.

CODE	DESCRIPTION	COLOUR
A 156550	Stainless Steel	Chrome
B 156551	Stainless Steel	Copper
C 156554	Steel	Anodized Steel

D Heat Lamp with Marble Base White 250w bulb included.

CODE	DESCRIPTION	COLOUR
156552	Stainless Steel	Chrome
156553	Stainless Steel	Copper

GN Countertop Heat Shades

- Single, Double and Triple variants.
- Suitable for holding 1/1 gastronorm pans.
- Durable stainless steel lamps with solid steel base.

E Single GN Heat Lamp with Base White 250w bulb included.

CODE	DESCRIPTION	COLOUR
156555	Stainless Steel	Chrome
156556	Stainless Steel	Matt Black

F Double GN Heat Lamp with Base 2 x White 250w bulbs included.

CODE	DESCRIPTION	COLOUR
156557	Stainless Steel	Chrome
156558	Stainless Steel	Matt Black

G Triple GN Heat Lamp with Base 3 x White 250w bulbs included.

CODE	DESCRIPTION	COLOUR
156559	Stainless Steel	Chrome
156560	Stainless Steel	Matt Black

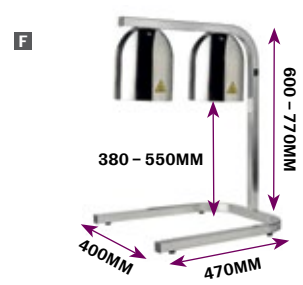

new

*ALL COUNTERTOP HEAT SHADE MODELS SUPPLIED WITH  13A PLUG.



1/1 Induction Buffet Plate

- This highly compact induction plate represents the ideal solution to keep 1/1 gastronorm containers at the desired temperature.
- Thanks to the absence of water, the buffet plate offers high efficiency and precision with thermostatic control from 75°C to 90°C.
- Maintains a constant temperature and eliminates humidity related problems.
- Its compact design means it can be easily moved.

1/1 Induction Buffet Plate

CODE	DESCRIPTION	POWER	W X D X H
PB 1/1 LP	1/1 Induction Buffet Plate	0.23kw	380 x 550 x 25mm

*SUPPLIED WITH 13A PLUG.



Induction Buffet Plate

- Bain-Marie alternative for maintaining the temperature of trays and casserole dishes.
- High visibility LED display.
- Practical IP67 touch control display.
- Double control of temperature and power display.
- Easy to use and clean.
- Energy efficient as there is no need to heat the unit up.

Induction Buffet Plate

CODE	DESCRIPTION	POWER	W X D X H
IH-BM	Countertop Buffet Plate	0.2kw	460 x 332 x 61mm

*SUPPLIED WITH 13A PLUG.

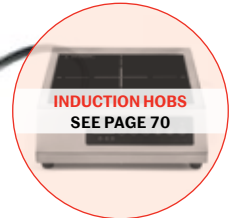

Mirage Induction Buffet Warmers

- Low wattage warmers with four power levels – low, medium, high and chafer preheat.
- Touch controls.
- LED indicator lights on control panel and glass top.
- Tempered black ceramic glass top is strong, non-porous and easy to clean.
- Safety features including over-heat protection, small-article detection, pan auto-detection, empty-pan shut-off.
- Connect up to three warmers with the included interconnect cords. The centre warmer must connect to the electrical outlet.
- Up to five standard size warmers or four 1/1 GN warmers can be connected to a 15 amp circuit.
- Storage compartment under warmer conveniently holds cords when not in use.
- Drop-In warmer can be installed overhanging countertop or countersunk.

Mirage Induction Buffet Warmers

CODE	DESCRIPTION	POWER	W X D X H
A 595027503	Standard Countertop	0.3kw	406 x 408 x 98mm
59502DW03	Standard Drop-In	0.3kw	406 x 408 x 98mm
B 595087503	1/1 GN Countertop	0.375kw	584 x 406 x 78mm
59508DW03	1/1 GN Drop-In	0.375kw	584 x 406 x 78mm

*ALL MODELS SUPPLIED WITH 13A PLUG.

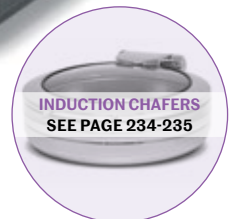

CONNECT UP TO 3 WARMERS WITH THE INCLUDED INTERCONNECT CORDS

Mirage Induction Drop-In Warmer

- Cutting-edge dial control with high-speed power and temperature level adjustment.
- Smart component placement means cord and fans are located under the top case assembly, improving appearance.
- Temperature memory – powers up to the last used temperature setting.



Mirage Induction Drop-In Warmer

CODE	DESCRIPTION	POWER	W X D X H
59642	Drop-In Warmer	0.65kw	368 x 318 x 73mm

*SUPPLIED WITH 13A PLUG.

2/4 Long Countertop Warmer

- Stainless steel well keeps food at optimal temperature for freshness and safety.
- Suitable for use with 2/4 long, 1/4 and 1/6 pans up to 150mm deep.
- Durable and easy to clean.
- Adjustable thermostatic control provides consistent temperature and maximises power efficiency.
- Front access dial for easy temperature adjustment.
- 10 temperature range settings from 40°C to 200°C.

2/4 Long Countertop Warmer

CODE	CAPACITY	W x D x H	POWER
72013CE-UK	2/4 Long GN	192 x 559 x 237mm	0.5kw

*SUPPLIED WITH 13A PLUG.



Bain-Marie with Drainage Tap

- Stainless Steel construction.
- Suitable for use with 1/1 GN 100mm Deep.
- Drain tap fitted at front for easy dispersal of water.
- Ideal for holding cooked food / vegetables and more.

Bain Marie with Drainage Tap

CODE	CAPACITY	W X D X H	POWER
15020	1/1 GN 100mm Deep	335 x 540 x 240mm	1.2kw

*SUPPLIED WITH 13A PLUG.



Heat & Hold Bain-Marie

- Efficiently heats and holds a wide variety of food.
- Suitable for use with 1/1 GN 100mm deep.
- Thermostatic controls ensure accurate heating.
- Lighted on/off switch and low-water indicator keep you informed.

Heat & Hold Bain Marie

CODE	CAPACITY	W X D X H	POWER
72550	1/1 GN 100mm Deep	350 x 553 x 230mm	1kw

*SUPPLIED WITH 13A PLUG.



BAIN MARIE POTS
& GN PANS
AVAILABLE TO ORDER

IntelliServ Food Warmer

- This countertop food warmer will keep various sauces, soups and toppings warm and ready in a minimal amount of space.
- Digital temperature control ensures accurate holding of delicate sauces and soups from the first serving to the last.
- Holds up to 1 x 1/3 GN pan or 2 x 1/6 GN, 150mm deep with a 5.7L capacity.
- Digital temperature display provides instant feedback on heat setting and status.
- Cool-touch rim protects users from heat zone during pan change-outs and in self-serve environments.
- Pans, lids and ladles sold separately.



IntelliServ Food Warmer

CODE	POWER	W X D X H
A 86341	0.5kw	202 x 391 x 237mm

*SUPPLIED WITH 13A PLUG.

Food Warmers

- Stainless steel water-bath warmers feature adjustable, pre-calibrated thermostat for accurate heat control.
- Dispense from a #10 can (2.8 L), included as standard with each unit.
- Stainless steel pump offers a 30ml maximum portion.
- Signature Touch™ (SBW) safely heats topping squeeze bottles, keeping them handy for plating.

Food Warmers

CODE	DESCRIPTION	POWER	W X D X H
B 84580	Fudge Server w/ pump	0.5kw	197 x 332 x 391mm
C 86925	Signature Touch™ Warmer	0.5kw	197 x 224 x 295mm
D 84990	Twin Fudge Server w/ 2 Pumps	0.5kw	432 x 343 x 389mm
94009	Spare #10 can for 84620, 84580		
86809	Spare 16oz squeeze bottle		

*ALL MODELS SUPPLIED WITH 13A PLUG.



Supreme Heated Merchandiser

- These warming merchandisers safely heat at the perfect serving temperature, so you can serve the best-quality butter, cheese, fudge, caramel or chilli dog sauce all-day.
- Stainless steel water-bath warmers feature adjustable, pre-calibrated thermostats with degree markings for complete control.
- Spout warmer models ensure safety when dispensing potentially hazardous foods.
- Dispense from a #10 can (2.8 L), included as standard with each unit.

Supreme Heated Merchandiser

CODE	POWER	W X D X H
E 83697	0.5kw	227 x 394 x 392mm

*SUPPLIED WITH 13A PLUG.



INCLUDES MAGNETIC MERCHANDISING SIGNS: FUDGE, CARAMEL & CHEESE

Heat & Hold Stainless Soup Kettle

- Designed to take chilled, cooked food to serving temperature.
- Thermoset fibre-reinforced resin well is self-insulating for maximum energy efficiency.
- Non-stick surface prevents scale build-up for easy cleaning and longer operating life.
- Must be used with water for maximum energy transfer.

Heat & Hold Stainless Soup Kettle Inset & hinged cover included.

CODE	POWER	CAPACITY	Ø x HEIGHT
72522	0.8kw	10.4L	Ø400 x H245mm

*SUPPLIED WITH  13A PLUG.



Heat & Hold Retro Soup Kettles

- Available in other colours.
- Designed to take chilled, cooked food to serving temperature.
- Ceramic base element ensures a fast start-up and consistent performance.
- Heavy-duty exterior body ensures the unit remains cool to the touch while operating.

Heat & Hold Retro Soup Kettles Eye-catching looks enhance your soup presentation.

CODE	COLOUR	POWER	CAPACITY	Ø x HEIGHT
7217455	Red	1.5kw	10.4L	Ø420 x H343mm
7217460	Black	1.5kw	10.4L	Ø420 x H343mm

*ALL MODELS SUPPLIED WITH  13A PLUG.



Mirage Induction Soup Kettles

- Induction heating means no water required, faster re-therm times and better temperature control.
- Sensors reduce food waste and make clean-up easier by preventing food from burning in near-empty insets.
- Digital controls allow precise temperature settings in °F or °C in 1-degree increments.
- Soup, crème soup, chilli, mac and cheese, and re-thermalise presets are included for speed and convenience.
- Sensors monitor the temperature at three points on the inset to activate the Stir Indicator LED which notifies the operator to stir the food to maintain temperature and quality.
- New contemporary lid design allows convenient, quick serving and helps condensation return to the inset to maintain food quality and prevent mess.
- Countertop and drop-in models.



A

NEW
CONTEMPORARY
LID DESIGN



B



Mirage Induction Soup Kettles

CODE	DESCRIPTION	COLOUR	POWER	CAPACITY	Ø x HEIGHT
74110310	Countertop	Silver	0.8kw	10.4L	Ø353 x H342mm
A 74110340	Countertop	Red	0.8kw	10.4L	Ø353 x H342mm
B 741103D	Drop-In	Silver	0.8kw	10.4L	Ø353 x H341mm

*ALL MODELS SUPPLIED WITH  13A PLUG.

Featured Brands

CAMBRO
TRUSTED DURABILITY

pujadas
A VOLLRATH COMPANY

VOLLRATH

Insulated Food Delivery

As food delivery demand continues to grow, your operation needs solutions that keep pace. Our meal delivery and insulated transport equipment protect food quality from kitchen to customer, extending holding times while maintaining safe temperatures. Reliable, easy to use, and built for busy operations, our delivery range helps you serve hotter food, fresher results, and happier customers every time.



Pro Cart Ultra Pan Carriers	96
Electric Ultra Pan Carriers	97
Insulated Ultra Camcarts	98
Temperature Maintenance Tools	99
Top Loading Camcarriers	100
Insulated Beverage Containers	100
Soup Camtainer	100
Front Loading Pan Carriers	101
GoBox Front Loading Carriers	103
GoBox Top Loading Carriers	103
GoBox Beverage Carrier	104
GoBox Meal Delivery Box	104
GoBox Accessories	105
Economy Delivery Bags	106
GoBag Delivery Bags	106
GoBag Catering Delivery Bags	107
GoBag Delivery Backpacks	107
Premium Delivery Bags	108
Premium Delivery Backpack	109
Heat Pad for Food Delivery Bags	109

Pro Cart Ultra™ Pan Carriers

The future of food holding and transport with the Pro Cart Ultra Pan Carriers.

- Passive, non-electric holding keeps food hot or cold for up to 4 hours.
- CFC-free polyurethane insulation with a tough polyethylene exterior.
- Cost-effective solution for short-term holding and food transport.
- Flexible configurations: Passive, Hot/Cold, Hot/Hot or Cold/Cold.
- Hot & Cold in One Cart – Ability to hold hot and cold food simultaneously with the hot or cold modules.
- Rapid recovery (modules): heats to 74°C in 15 minutes; cools to 0.3°C.
- Up to 30% more energy-efficient than metal cabinets.
- Ergonomic handles, nylon latches and 6" heavy-duty casters (2 locking).



FULL RANGE OF MODELS AVAILABLE AT FEM.CO.UK

INSULATED FOOD DELIVERY



COMES WITH PASSIVE MODULE (PCMPX) - PERFECT FOR SHORT TERM HOLDING AND TRANSPORT.



NEW MODEL



INTERCHANGEABLE MODELS

ORDER THE CONFIGURATION THAT MEETS YOUR NEEDS. HOT AND COLD MODULES CAN BE ORDERED SEPARATELY TO SWITCH OUT AS MENU NEEDS CHANGE.

Pro Cart Ultra™ Passive GN Pan Carriers Non-Electric, Passive Holding. Retains hot or cold food safely for up to 4 hours without electricity.

CODE	DESCRIPTION	CAPACITY	W X D X H
PCUL1000P	1 Passive compartment	14 x 1/1 D65mm	762 x 966 x 1004mm
PCU800PP	2 Passive compartments	12 x 1/1 D65mm	556 x 864 x 1501mm
PCU1000PP	2 Passive compartments	14 x 1/1 D65mm	559 x 864 x 1702mm
PCU2000PP	2 Passive compartments	28 x 1/1 D65mm	762 x 966 x 1727mm

HOT MODULE

- Safely maintain food temperatures between 65.6°C to 73.9°C with gentle, non-radiant heat.
- Adjustable temperature from 21°C to 85°C.
- Heats from room temperature to 73.9°C in 15 minutes.
- 20 second recovery time.*



COLD MODULE

- Thermoelectric cooling technology is safe for transport.
- Cools down to 0.28°C without a compressor.
- Adjustable temperature from 0.28°C to 21°C.
- 23 second recovery time.*



PASSIVE MODULES ALSO AVAILABLE

*AVERAGE RECOVERY TIME BASED ON AMBIENT TEMPERATURE OF 23.33°C, EMPTY COMPARTMENTS - DOOR OPEN FOR 30 SECONDS.

Additional Hot Module

PCMHX 1 Required per compartment

*HOT & COLD MODULES - SUPPLIED WITH 13A PLUG.

Additional Cold Module

PCMCX 1 Required per compartment

Electric Ultra Pan Carriers®

MORE COLOURS AVAILABLE
CONTACT FOR AVAILABILITY AND PRICING.

INSULATED FOOD DELIVERY

BUILT-IN THERMOMETER

NON-CORROSIVE HEATING UNIT MAINTAINS A SAFE TEMPERATURE RANGE OF 65°-74°C

VENT CAP EQUALISES PRESSURE AND RELEASES STEAM



SINGLE 230MM NYLON LATCH PROVIDES QUICK AND SECURE OPENING AND CLOSING

MOULDED HANDLES WON'T BREAK OFF BELOW REMOVABLE CORD STOWS SECURELY FOR TRANSPORT

TOUGH POLYETHYLENE EXTERIOR STAYS COOL TO THE TOUCH BELOW THICK FOAM INSULATION RETAINS TEMPS FOR HOURS EVEN WHEN UNPLUGGED



Electric Ultra Pan Carriers® Electric pan carrier extends hot holding time and ensures food safety.

CODE	CAPACITY	COLOUR	POWER	W X D X H
UPCH4002401	6 x 1/1 GN D65mm	Slate Blue	0.265kw	460 x 670 x 630mm
UPCH8002401	12 x 1/1 GN D65mm	Slate Blue	0.53kw	520 x 690 x 1372mm
UPCH16002401	24 x 1/1 GN D65mm	Slate Blue	1.01kw	715 x 820 x 1350mm

*ALL MODELS SUPPLIED WITH  13A PLUG.

H-Series Accessories

CODE	DESCRIPTION	W x D x H
CD400	Camdolly®	530 x 710 x 230mm
400STP	Strap for UPCH4002	L500mm

- Enables HACCP compliance by maintaining safe, hot food temperatures.
- Gentle 71°C heat maintains food moisture.
- 45-minute preheat time from room temperature.
- 90-second recovery after the door is opened and closed.
- Uses less energy than three standard 100-watt light bulbs.
- Transports on castors or CD400 Camdolly®.



Insulated Ultra Camcarts®

MORE COLOURS
AVAILABLE
CONTACT FOR
AVAILABILITY AND
PRICING.

- Double-compartment, high-capacity carts hold and transport food.
- Tough, polyethylene shell and thick foam insulation.
- Airtight removable gaskets maintain safe food temperatures for hours.
- Durable nylon door latches open easily and close securely.
- Doors open 270°C for easy loading and unloading.
- Moulded-in handles ensure easy manoeuvring.
- Mounted on wheels.
- 12 rails support gastronorm food pans and trays.
- Vent cap to equalise internal pressure and check temperature.



INSULATED FOOD DELIVERY

Insulated Ultra Camcarts® Hold and transport gastronorm food pans.

CODE	CAPACITY	COLOUR	W x D x H
UPC600401	8 x 1/1 GN D65mm	Slate Blue	520 x 690 x 1145mm
UPC800401	12 x 1/1 GN D65mm	Slate Blue	520 x 690 x 1370mm
UPC1200401	16 x 1/1 GN D65mm	Slate Blue	725 x 820 x 1160mm
UPC1600401	24 x 1/1 GN D65mm	Slate Blue	715 x 820 x 1350mm



UPC600

UPC800

UPC1200

UPC1600

Five Steps for Peak Performance

- 1 Ensure all parts are operational
- 2 Preheat or pre-chill
- 3 Use shallow pans and cover whenever possible
- 4 Minimise door opening and closing
- 5 Minimise empty space



INSULATED FOOD DELIVERY

Temperature Maintenance



CAMCHILLER®

CAMWARMER®

THERMOBARRIER®

Camchiller®

- An easy-to-use, cold food holding temperature tool.
- Extend cold holding time or enhance safe holding below 5°C when frequent access is required.
- Freeze first then use to pre-chill cabinet before loading.

CODE	DESCRIPTION	W X D X H
CP3253	GN Full Size	330 x 530 x 38mm
CP2632	GN Half Size	264 x 324 x 38mm

Camwarmer®

- Use for added insurance to keep hot foods hot during holding and transporting.
- Keep in cabinet with hot foods to extend holding time or enhance safe holding above 65°C when frequent access is required.

CODE	DESCRIPTION	W X D X H
1210PW	For 400/600/800 models	275 x 340 x 40mm

Thermobarrier®

- A highly valuable yet economical temperature maintenance tool for caterers.
- Use to minimise empty space and food temperature loss within a partially loaded compartment.

CODE	DESCRIPTION	W X D X H
300DIV	For UPC600	330 x 530 x 25mm
400DIV	For UP400/UPC800	330 x 540 x 25mm
1200DIV	For UPC1200	335 x 530 x 35mm
1600DIV	For UPC1600	335 x 530 x 38mm

Insulated Top Loading Camcarriers®

- Durable polypropylene construction.
- Polyurethane injected foam insulated.
- Built-in seal and wide nylon latches for better temperature retention.
- Moulded-in handles on all four sides.
- Stackable.
- Transport full or fractional GN food pans.
- Lightweight.
- Interlock and stack to ease transporting and maximise storage space.

S-Series Camcarriers® Available in various colours.

CODE	CAPACITY	W x D x H
A UPCS140	1/1 GN - D100mm	640 x 435 x 220mm
B UPCS160	1/1 GN - D150mm	640 x 435 x 260mm
C UPCS180	1/1 GN - D200mm	640 x 435 x 305mm

S-Series Accessories

CODE	DESCRIPTION
D CD160	Camdolly* to suit Camcarriers



Insulated Beverage Containers

- One-piece polyethylene body.
- Polyurethane foam insulated.
- Moulded-in handles.
- Nylon latches.
- Vent cap to equalise internal pressure and check temperature.
- Interlock and stack to ease transporting and maximise storage space.

Ultra Camtainers® Available in various colours.

CODE	CAPACITY	CUPS	W x D x H
E UC250	10.4L	50	300 x 425 x 500mm
F UC500	19.9L	94	300 x 425 x 680mm
UC1000	39.7L	192	415 x 520 x 655mm



Soup Camtainer®

Soup Camtainer® Available in various colours.

CODE	CAPACITY	CUPS	W X D X H
G 350LCD	12.7L	60	230 x 420 x 470mm

Ultra Pan Carrier® UCP300

- Heavy-duty seamless construction resists dents, cracks and harsh kitchen use.
- Insulated design safely holds hot or cold food for hours.
- Front-loading access with a fully removable, gasketless door for easy cleaning.
- Built-in door labelling area for routing, contents or service info.
- Compact footprint that fits easily in vehicles and stacks with compatible carriers.
- Holds up to six full-size GN 1/1 food pans (also accommodates 1/2 and 1/3 pan sizes).

Ultra Pan Carrier® UCP300

CODE	CAPACITY	W x D x H
UPC300	3 x 1/1 GN D100mm	432 x 654 x 568mm



Ultra Pan Carrier® UCP400

- One-piece seamless construction that resists wear, impact, stains and cracking.
- Ergonomic, unbreakable moulded-in handles for secure two-person lifting and carrying.
- Front-loading access with a sturdy nylon latch for fast opening and closing.
- Pop-up vent to control humidity and pressure inside the carrier.
- Holds up to six full-size GN 1/1 food pans (also accommodates 1/2 and 1/3 pan sizes).
- NSF Listed, easy to clean, and dishwasher safe.
- Stackable with other Cambro carriers (like UPCS400 and UPCH400) to maximise storage and transport efficiency.

Ultra Pan Carrier® UCP400 Hold and transport gastronorm food pans with the classic heavy-duty, seamless insulated carrier.

CODE	CAPACITY	W x D x H
A UPC400	6 x 1/1 GN D65mm	425 x 620 x 570mm



REMOVABLE GASKET PROVIDES AN AIRTIGHT SEAL

S-Series Ultra Pan Carrier®

- Ultra dependable, ultra-durable front-loading pan carrier.
- Front-loading insulated design with thick foam insulation and a built-in vent to maintain quality and temperature.
- Ergonomic moulded-in handles and a sturdy nylon latch for secure, two-person carrying and quick access.
- Fully removable, gasketless door for faster, easier cleaning and improved hygiene.
- Menu clip on the door for easy contents labelling and routing.
- Integrated pan staging area on top of the carrier to assist with service and workflow.
- Stackable and dishwasher safe, and compatible with optional accessories like camdollies and caster kits for easier transport.
- Holds up to 6 full-size GN 1/1 pans (65 mm deep) or equivalent configurations of half/third pans.

S-Series Ultra Pan Carrier® Hold and transport food pans with ease of cleaning and added convenience features like removable door, menu clip, and staging area.

CODE	CAPACITY	W x D x H
B UPCS400	6 x 1/1 GN D65mm	460 x 635 x 630mm

S-Series Accessories

CODE	DESCRIPTION	W x D x H
C CD400	Camdolly® for UPC400 & UPCS400	530 x 710 x 230mm
UPCS400CK	Optional castor kit	Ø127mm

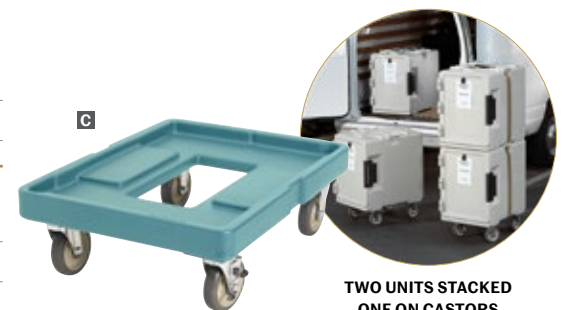

TWO UNITS STACKED ONE ON CASTORS

GoBag™ Catering Delivery Bags

INSULATED FOOD DELIVERY

- Ultra-lightweight transporters that offer superior temperature retention to protect food safety and excellent durability to withstand heavy commercial use.
- Lightweight – Made of EPP (Expanded Polypropylene) – an eco-friendly, high-performance foam material.
- Thermal Insulation – Holds hot or cold food safely for many hours.
- Great structural Strength – capable of hanging significant loads while maintaining its shape and form.
- Excellent Energy Absorption – can withstand substantial impact without damage.
- Chemically Inert – unaffected by oil, grease and most chemicals.
- Designed to hold 1/1 pans along with Camwarmers or Camchillers. Line your Cam GoBox with a Cambro GN Food Pan and Seal Cover for the ultimate food-safe solution.
- Dishwasher safe.
- Built-in label area keeps plastic menu tags in place for easy content identification or routing.
- Cam GoBoxes inter-stack and also stack with major competitive brands.
- CFC-Free.
- 100% Recyclable.



4-Sided Handling – Thoughtfully designed built-in handles along the top of front loading models allow them to be easily carried from all four sides.

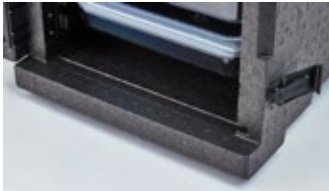

Drip-Resistant – Built-in condensation barrier helps front loaders to remain drip-resistant.



Easy Identification – A built-in label area keeps plastic menu tags in place.



Easy Loading & Unloading - Interior walls recess making loading and unloading pans easy.



Full 270° Access – Durable hinges and latches allow door to remain securely open at the side for easy access.



Accessories - Various accessories available to assist holding times.

Temperature Tools



Camchillers are designed to extend the cold holding time of your food. Simply freeze flat overnight and place at the top of your carrier.



Camwarmers are designed to extend the hot holding time of your food. Place in a hot water bath for 35 minutes and place at the bottom of your carrier.

ACCESSORIES
SEE PAGE 105



Thermobarriers are designed to keep hot or cold air concentrated within your front-loading carrier. As food pans are removed, use the Thermobarrier to close up any space created.

Cam GoBox™ Insulated Carriers

GN Front Loader

CODE	CAPACITY	W X D X H
A EPP300	4 x 65mm 1/1 GN Pan (60L)	440 x 640 x 475mm
B EPP400	6 x 65mm 1/1 GN Pan (86L)	440 x 640 x 625mm

Bakery Front Loaders

CODE	CAPACITY	W X D X H
EPP4060F6R	6 x Baking Pans (60 x 40cm) (126L)	540 x 770 x 687mm
EPP4060F9R	9 x Baking Pans (60 x 40cm) (126L)	540 x 770 x 687mm

GN Top Loader

CODE	CAPACITY	W X D X H
EPP260	15cm 1/2 GN Pan (16.9L)	330 x 390 x 257mm
EPP280	20cm 1/2 GN Pan (22.3L)	330 x 390 x 316mm
C EPP160	15cm 1/1 GN Pan (35.5L)	600 x 400 x 257mm
EPP180	20cm 1/1 GN Pan (46L)	400 x 600 x 316mm
EPP180S	20cm 1/1 GN Pan (43L)	400 x 600 x 282mm
EPP4060T200	20cm 40 x 60cm Crates (53L)	690 x 490 x 270mm
D EPP4060T300	30cm 40 x 60cm Crates (80L)	690 x 490 x 370mm

Cam GoBox™ Top Loader with Flip Lid

- Access only the items you need while keeping the contents of your GoBox secure.
- Flip the lid to stock or serve, then seal to hold safe temperatures for 4+ hrs.
- Protect against contaminants and temperature loss.

Top Loader with Flip Lid

CODE	DESCRIPTION	W x D x H
EPP180FL	GoBox with Flip Lid (46L)	400 x 600 x 316mm
EPPFLID	Flip Lid Only	400 x 600 x 40mm

Cam GoBox™ Large Handle Top Loader

- Ergonomic comfort handles allow easy and safe lifting of heavier loads.
- Recessed interior walls for easy loading and unloading.
- Straight interior walls allow room for stacking pans inside.
- Optional accessories available.

GN Large Handle Top Loader

CODE	CAPACITY	W x D x H
EPP180LH	20cm 1/1 GN Pan (46L)	400 x 680 x 321mm



STACKABLE MODEL

INSULATED FOOD DELIVERY



Cam GoBox™ Top-Loading Pizza Carriers

- Available in four different heights that hold from 2 to 8 pizzas.
- Vent releases steam to keep crust crispy.
- Holds 33 x 33cm pizza boxes.
- 4+ hours temperature retention.

Top-Loading Pizza Carriers

CODE	DESCRIPTION	CAPACITY	W x D x H
A EPPZ35100	WITHOUT STRAP	2 Pizzas	410 x 410 x 174mm
EPPZ35175RST	RED STRAP	4 Pizzas	410 x 410 x 249mm
B EPPZ35265RST	RED STRAP	6 Pizzas	410 x 410 x 339mm
EPPZ35330RST	RED STRAP	8 Pizzas	410 x 410 x 404mm



Multi-purpose Top Loader

- Designed to hold disposable dishware or 5L Gelato pans.
- Recessed handles for easy transportation.

Multi-purpose Top Loader

CODE	CAPACITY	W x D x H
C EPP180X	41L	430 x 610 x 270mm
EPP180XL	50.5L	430 x 610 x 320mm
EPP180XLT	64.5L	430 x 610 x 390mm



Beverage Carrier with Carrying Strap

Beverage Carrier with Carrying Strap Designed to hold 12 x 750ml wine bottles or 12 x 1.5L plastic bottles.

CODE	DESCRIPTION	CAPACITY	W x D x H
EPPBEVRDST	Red Strap	35L	335 x 420 x 420mm



EPP Meal Delivery Solution

Single-Serve Meal Delivery Solution Single-serve meal box with separate compartments to hold hot and cold foods at safe temperature for approximately 1 hour. Lightweight, stackable and dishwasher safe.

CODE	DESCRIPTION	W x D x H
EPPMD4835	4 Compartment Cam GoBox	350 x 480 x 167mm



GoBox™ Accessories

Cam GoBox™ Beverage Holder Maintains hot or cold drink temperatures for 3 hours.

CODE	DESCRIPTION	DRINK CAPACITY
A EPPBEVH1	Single Holder	3
EPPBEVH2	Set of 2 Holders	6
EPPBEVH5	Set of 5 Holders	15



Cam Go Heat Warms to 75°C in just 10 minutes. Place in the bottom of your insulated carrier or use to hold or display hot foods on a table top, counter or buffet.

CODE	DESCRIPTION
B CGH200WUK	Camwarmer for GN 1/1 GoBoxes

*SUPPLIED WITH  13A PLUG.



Temperature Maintenance

CODE	DESCRIPTION
C HP3253	Camwarmer for GN 1/1 GoBoxes
HP2632	Camwarmer for GN 1/2 GoBoxes
CP3253	Camchiller for GN 1/1 GoBoxes
CP2632	Camchiller GN 1/2 GoBoxes
EPP3253DIV	Thermobarrier Fits EPP300 & EPP400
D EPPCTS	Camchiller Insert Fits EPP180, EPP180S
EPPCTL	Camchiller Insert Fits EPP180LH



Accessories

CODE	DESCRIPTION
E CD3253EPP	Camdolly fits GN 1/1 GoBoxes
CD4060EPP	Camdolly fits 4060 Bakery GoBoxes
F EPP3253LID	Colour Lid for EPP180, EPP180S, EPP160
G EPPID5	ID Clips fit all GoBoxes'



Economy Delivery Bags

Pizza Delivery Bags

- Reinforced handles for ease of transport.
- Thermal insulation to maintain temperature.
- Hanging band and transparent pocket.
- Thick, sturdy and easy to clean material.

Pizza Delivery Bags

CODE	DESCRIPTION	COLOUR	W X D X H
A 99020	Medium Pizza Bag	Red	450 x 450 x 160mm
99021	Large Pizza Bag	Red	495 x 495 x 260mm



Catering Delivery Bags

- Thermal insulation to preserve temperature.
- Easy to clean waterproof interior.
- Thick and resistant material.
- Transparent pocket and reinforced handles for easy transport.

Catering Delivery Bags

CODE	DESCRIPTION	COLOUR	W X D X H
99030	Small Catering Bag	Black	380 x 305 x 380mm
B 99031	Large Catering Bag	Black	560 x 360 x 360mm



GoBag™ Delivery Bags

Pizza GoBags™

- Thick, sturdy 600-denier polyester fabric.
- Breathable material protects food quality.
- High-density insulation for superior temperature retention.
- Heavy-duty, sewn-in nylon straps and carry handle.
- Heavy-duty ticket pouch.
- Machine washable.
- Lightweight for easy carrying.
- Black as standard, red available to order on certain models.

Standard Pizza Bags

CODE	DESCRIPTION	INTERIOR	W X D X H
C GBP216	2 x 16" or 3 x 14" pizzas	NYLON	420 x 457 x 165mm
D GBP318	3 x 18" or 4 x 16" pizzas	NYLON	445 x 508 x 191mm
GBP518	5 x 18" or 6 x 16" pizzas	NYLON	495 x 495 x 318mm
GBP220	2 x 20" or 3 x 18" pizzas	NYLON	527 x 552 x 165mm



GoBag™ Catering Delivery Bags

- Breathable material protects food quality by controlling moisture and odours.
- Extra strength high-density insulation keeps food hot or cold during holding or delivery.
- Thick, sturdy nylon fabric.
- Heavy-duty, sewn-in straps are strong enough to handle heavy loads.
- Multiple pockets designed to hold receipts, coupons, condiments etc.

BLACK AS STANDARD, RED AVAILABLE TO ORDER ON CERTAIN MODELS



INSULATED FOOD DELIVERY

Folding Catering Bags

CODE	DESCRIPTION	COLOUR	INTERIOR	W X D X H
GBD101011	Small Folding Delivery Bag	Black	Vinyl	255 x 255 x 280mm
A GBD121515	Medium Folding Delivery Bag	Black	Vinyl	305 x 380 x 380mm
B GBD211417	Large Folding Delivery Bag	Black	Vinyl	535 x 355 x 430mm

Standard Catering Bags

CODE	DESCRIPTION	COLOUR	INTERIOR	W X D X H
C GBD13913	Small Top Loading Delivery Bag	Black	Vinyl	330 x 230 x 330mm
GBD151212	Sandwich Bag	Black	Nylon	380 x 305 x 305mm
D GBD211414	Large Delivery Bag for 1/1 pans	Black	Vinyl	533 x 355 x 355mm

GoBag™ Delivery Backpacks

- Durable, waterproof design wipes clean.
- Maintains safe temperatures and food quality.
- Comfortable and secure to wear walking or biking.
- Easily separate menu items with the included divider.
- Designed with a front zipper for easy loading and unloading.
- Padded shoulder straps can be adjusted for comfort.
- Includes 2 buckles + hook/loop fastener to close.
- Features side mounted straps for hand carrying.
- Folds for compact storage between use.



GoBag™ Delivery Backpacks

CODE	DESCRIPTION	W X D X H
A GBBP111417	Small Delivery Backpack	279 x 355 x 430mm
B GBBP151417	Large Delivery Backpack	381 x 355 x 430mm

Premium Delivery Bags

INSULATED FOOD DELIVERY



Maintain temperature longer to maximise food quality

- Moisture-resistant outer shell.
- Foil liner insulating and directing hot and cold temps.
- Thick poly batting insulation on all sides.

Durable construction for longevity and to protect contents

- Sturdy floor bottoms to ensure stability.
- Heavy-duty handles and webbing for strength and comfort.
- Reinforced stitching for superior strength and durability.

Driver safety and comfort

- Reflective piping for safer night time delivery.
- Double handles and longer, heavy-duty shoulder straps.

Convenient storage and handling

- Bags and wire inserts fold easily for storage.
- Vinyl liners for fast and easy clean-up.
- Hanging loop for drying.



Catering Delivery Bags

- Removable spill liner for easy clean up.
- Durable pan separators provide additional support for stacking pans.
- Reinforced side handles for easy lifting (large size).

Pizza Delivery Bags

- Heavy-duty locking clips to keep product secure.
- Unique anchor strap to secure bag to a bike tray or for hanging.
- Extra handle for stabilisation when unloading.

Catering Delivery Bags

CODE	DESCRIPTION	CAPACITY	W X D X H
VDBM300	Medium Catering Bag with Vinyl Liner	2 x ½ GN 100mm	432 x 330 x 229mm
VCBL300	Large Catering Bag with Removable liner & Pan Separators	3 x 1/1 GN 100mm	381 x 584 x 356mm

Pizza Delivery Bags

CODE	DESCRIPTION	CAPACITY	W X D X H
VPB316	16" Pizza Bag	4 x 14" or 3 x 16" Pizzas	445 x 445 x 229mm
VPB318	18" Pizza Bag	4 x 14/16" or 3 x 18" Pizzas	483 x 483 x 229mm



Delivery Backpack with Integrated Frame

Delivery via bike or scooter can be an efficient way to bring food to your customers, especially in urban areas. But without the proper bag, this method can be problematic when it comes to food quality.

- Maintain temperature and quality for longer to maximise the delivery of food items.
- Durable construction for longevity and to protect the contents of the bag.
- Reflective piping, double handles and heavy-duty shoulder straps for driver safety and comfort.
- Vinyl liners for fast and easy clean-up.
- Large PVC window for branding, menus or brochures.
- Integrated frame for added stability.

Delivery Backpack

CODE	W x D x H
VDBBM300	406 x 406 x 330mm



Heat Pad for Food Delivery Bags

- Preheats the delivery bag to better maintain food quality and extend the delivery range.
- Ideal for food delivery services that want to deliver dine-in quality to the customer's doorstep.
- Heat pad slips into a pocket inside the Vollrath delivery bags and the cord exits through a grommet in the bag.
- To preheat the bag, simply connect the heat pad to the included AC power cord.

Heat Pad for Food Delivery Bags

CODE	DESCRIPTION
VAC1212	Heat pad

*SUPPLIED WITH  13A PLUG.



Featured Brands



Icemaking

The perfect ice cube is clear, great-tasting, and ready on demand. Elevate your menu with smoothies, iced coffees, and frozen cocktails, or create eye-catching chilled food displays over ice. Whatever your application, our icemaking solutions help you maximise performance and presentation. From flakes, nuggets, or cubes to outputs from 10kg to 1000kg per day, we offer everything from compact undercounter units to high-capacity modular icemakers. Built to the highest standards and designed with energy efficiency in mind, our icemaking range delivers reliability, flexibility, and ice you can count on day after day.





Ice Type Guide	112
CrystalCraft	
Undercounter Ice maker	113
Sotto Undercounter Ice makers	113
NEO Integral Storage Ice makers	114
Flake Ice makers	115
Nugget Ice makers	115
Countertop Nugget Ice Maker & Dispensers	115
Indigo NXT Modular Ice makers	116
Modular Ice maker Bins	117
M Series Modular Ice makers	118
Ice Machine Filtration Systems	119

Which Ice is Right For You?



Gourmet

Hard, clear, individual ice cube with unique octagon shape 34 x 33mm dimensions, maximum cooling with nearly 100% ice to water ratio.



Regular

Hard, clear ice cube with unique "rhomboid" shape 29 x 29 x 22mm dimensions, 32 cubes per pound of ice, maximum cooling with nearly 100% ice to water ratio.



Dice

Hard, clear ice cube with unique "rhomboid" shape 22 x 22 x 22mm dimensions, 48 cubes per pound of ice, maximum cooling with nearly 100% ice to water ratio.



Half Dice

Hard, clear ice cube with unique "rhomboid" shape 10 x 29 x 22mm dimensions, 96 cubes per pound of ice, maximum cooling with nearly 100% ice to water ratio.



Nugget

Easy to chew but hard enough to be dispensed without hand scooping, 0.95 width to 13mm length on average.



Flake

Small, soft pieces of ice with a 73% ice to water ratio. Perfect for displaying products and hand scooping into drinks.



CrystalCraft™ Undercounter Icemaker

Manitowoc's CrystalCraft offers clear, individual 1x1" cubes that melt slowly, enhancing the flavour and enjoyment of the most prestigious cocktails. With high production and storage, this sleek undercounter is the perfect solution for the most challenging operations.

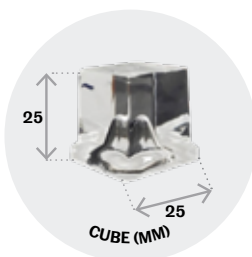
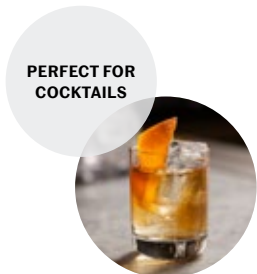

- New CrystalCraft™ cube is pure and clear making it perfect for premium cocktails.
- The 1x1" square cube ice adds to the presentation of the drink and differentiates it from the competition.
- Sleek undercounter design is ideal for contemporary bars and restaurants.
- Simple one-touch cleaning makes life easy for busy operators.
- Heavy-duty stainless-steel cabinet resists corrosion.
- Designed with fewer moving parts to replace.
- Energy-efficient R290 refrigerant.
- Air-cooled as standard.
- Adjustable legs as standard (4.5" – 6").

CrystalCraft™ Icemaker

Undercounter icemaker with integral storage. Air cooled condenser.

CODE	PROD. 24 HRS	STORAGE	W x D x H
USP0100A	45kg	17kg	500 x 580 x 952mm

*SUPPLIED WITH 13A PLUG.

SOTTO™ Series

Undercounter Icemakers



NEW SOTTO ICEMAKERS YIELD UP TO 43% MORE ICE



- Redesigned refrigeration system yields up to 43% more ice.
- Compact, attractive undercounter icemakers.
- Air-cooled as standard.
- Front breathing facilitates installation undercounter or as built-in.
- Easy access door, slides up and out of the way.
- Levellers come as standard, with adjustable legs optional.
- Slide-out air filter.
- Intuitive control system.
- High-grade stainless steel exterior.
- Supplied with R290, the energy-efficient, environmentally-friendly refrigerant.
- No side clearance required.

Sotto Series Icemakers

Undercounter icemaker with integral storage. Air cooled condenser.

CODE	PROD. 24 HRS	STORAGE	W x D x H
UGP020A	22kg	5.5kg	450 x 475 x 650mm
UGP030A	32kg	5.5kg	450 x 475 x 650mm
UGP040A	53kg	14kg	550 x 550 x 800mm
UGP050A	57kg	14kg	550 x 550 x 800mm
UGP080A	76kg	30kg	700 x 600 x 900mm

*ALL MODELS SUPPLIED WITH 13A PLUG. HEIGHTS SHOWN DO NOT ACCOUNT FOR LEVELERS.

CrystalCraft™ Accessories

CODE	DESCRIPTION
AR-10000-P	Water Filter

Sotto Series Accessories

CODE	DESCRIPTION
AR-10000-P	Water Filter for use with UG Series
K00345	Set of Adjustable Legs (H114 - 152mm)
VCL24S	3.8-litre Condensate Pump
934009-G1	Installation Kit
K00VCMA-Kit	Drain Pump Kit

NEO®

GET ON BOARD

With Integrated Water Filtration

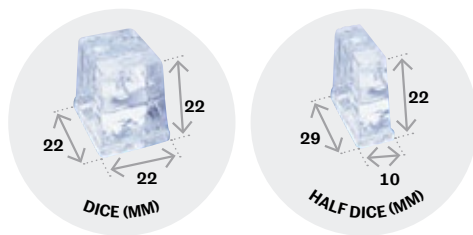

Get On Board! NEO undercounter ice machines with integrated water filtration are designed to provide ice right where you need it – within reach. Improvements in Sustainability, Convenience and Filtration.



- **Great Taste in Every Cube** - Cleaner, clearer ice that enhances beverage quality and customer satisfaction.
- **Optimised Performance** - Built-in filtration keeps the machine running at peak efficiency, day in, day out.
- **Lower Maintenance** - Reduced scale build-up helps extend service intervals and protect the machine over time.
- **Eco-Friendly Refrigerant (R290)** - Next-generation cooling technology with a significantly reduced environmental impact.
- **Reduced Running Costs** - Improved energy and water efficiency helps operators save on utilities.
- **Clear Status Indicators** - Instant visibility of machine status and service alerts—no guesswork for operators.
- **Sleek Foodzone Design** - Modern, easy-access layout that simplifies cleaning and routine maintenance.



NEO Series Ice makers with Integrated Water Filtration Available in Regular, Dice and Half Dice cube sizes - Dice as standard.

Dice NEO Series Ice makers

CODE	PROD. 24 HRS	BIN OPTIONS	W X D X H
UDP0140A	60kg	40kg	660 x 724 x 826mm
UDP0240A	94kg	40kg	660 x 724 x 826mm
UDP0310A	132kg	54kg	762 x 724 x 826mm

*ALL MODELS SUPPLIED WITH 13A PLUG.

NEO Accessories

CODE	DESCRIPTION	CODE	DESCRIPTION
AR-10000-P	Water Filter	K00519	Luminice Growth Inhibitor Kit
VCMA20S	2-litre Condensate Pump	934009-G1	Installation Kit
K00445	Short Leg Kit	K00VCMA-Kit	Drain Pump Kit

Half Dice NEO Series Ice makers

CODE	PROD. 24 HRS
UYPO140A	63kg
UYPO240A	104kg
UYPO310A	135kg



U80 Series Integral Storage Ice makers

- Compact size for easy placement under counters.
- Easy access door, slides up & out of the way.
- Patented cleaning and sanitising technology.
- Includes Manitowoc's proven vertical evaporator.
- Front air intake and exhaust.
- Levellers come as standard, with adjustable legs optional.



U80 Series Ice makers Air cooled as standard. Produces dice ice.

CODE	PROD. 24 HRS	STORAGE	W X D X H
UDP0080A	46kg	14kg	500 x 567 x 790mm

*SUPPLIED WITH 13A PLUG.



Flake and Nugget Icemakers

WARRANTY 5 YEARS PARTS	WARRANTY 3 YEARS LABOUR	WARRANTY 3 YEARS PARTS & LABOUR
ICEMAKER COMPRESSOR		ALL OTHER COMPONENTS



Flake

- Offers small, hard bits of ice ideally for presentation applications.
- Flake ice forms completely around the contact item and cools quickly.

Nugget

- High load capacity bearings for enhanced reliability.
- Heavy-duty stainless steel cabinet resists corrosion.
- Easy access door, slides up and out of the way.
- Bite-size nugget that boasts one of the industry's best ice to water ratios for nugget ice, maximising cooling capacity while minimising drink dilution.
- Perfect for carbonated beverages and blended smoothies.
- Undercounter installation: UNP0200A for kitchen counters, UNP0300A for bar height counters.



Flake and Nugget Icemakers Air cooled as standard.

CODE	ICE TYPE	PROD. 24 HRS	STORAGE	W X D X H
UFP0244A	Flake	125kg	20kg	500 x 660 x 842mm
UFP0388A	Flake	175kg	40kg	738 x 690 x 1072mm
UFP0399A	Flake	175kg	55kg	738 x 690 x 1172mm
UNP0200A	Nugget	90kg	14kg	500 x 660 x 842mm
UNP0300A	Nugget	142kg	27kg	738 x 690 x 1004mm

*ALL MODELS SUPPLIED WITH  13A PLUG.

Countertop Nugget Ice Maker & Dispensers



- Trouble-free ice dispensing, simply place cup under chute and press button to activate.
- Compact space-saving design.
- Stainless steel front panel for easy cleaning and reduced hardwater staining in the dispense area.
- Removable and cleanable water drip basin.
- Hidden connections for better aesthetics.
- CNP0201AL and CNP202AL can dispense ice, water and ice/water combo and come with lever-activated touchless dispensing.

WARRANTY
3
YEARS
PARTS & LABOUR

ENERGY SAVING
FEM APPROVED

Countertop Nugget Ice Maker & Dispensers

CODE	DISPENSES	PROD. 24 HRS	STORAGE	W X D X H
CNP0200A	Nugget Ice	88kg	5kg	396 x 708 x 871mm
CNP0201AL	Nugget Ice / Water	129kg	4.5kg	413 x 610 x 890mm
CNP0202AL	Nugget Ice / Water	129kg	9kg	413 x 610 x 1070mm

*ALL MODELS SUPPLIED WITH  13A PLUG.

INDIGO[®] NXT

The next generation ice machine...

NEW SIZES
AVAILABLE

WARRANTY
5
YEARS
PARTS & LABOUR
ICEMAKER
EVAPORATOR

WARRANTY
5
YEARS
PARTS
ICEMAKER
COMPRESSOR

WARRANTY
3
YEARS
LABOUR

WARRANTY
3
YEARS
PARTS & LABOUR
ALL OTHER
COMPONENTS

> Next level of simplicity

- New easyTouch[®] display provides full status of ice machine at all times.
- 240x320 pixels, 262K colour, 2.8" diagonal reflective touch display.
- Features include: ice machine operating status, step-by-step cleaning instructions, one-touch access to asset information and a startup wizard.
- Multiple languages available.



> Next level of sanitation

- New ice storage D Bin, with hinged door that swings open.
- Front-facing evaporator allows easy access to food zone without removing top or side covers.
- Optional integrated advanced sanitation solution Luminice[®] II keeps food zone cleaner longer.
- New ergonomic NSF scoop keeps the thumb and knuckles from touching the ice.



> Next level of reliability

- Over half a million hours of testing in the development of Indigo NXT.
- New reliability and HALT used to ensure that all machines will provide years of outstanding service.
- EasyTouch display provides service data.
- Firmware functional upgrades are easily made through control board USB port.



> Next level of energy efficiency

- Up to 43% more energy efficient than previous models, significantly lowering the cost of ownership.
- All models are AHRI certified and exceed the stringent 2018 DOE minimums for energy usage.
- Minimise global warming potential while maintaining high performance with *R290 propane refrigerant.
- Programmable ice production and scheduling – including documenting ice volume, the on/off time and bin level – help reduce the day-to-day running costs of operation including energy use, water consumption and electricity.



*ALL MODELS EXCEPT IDT0900A, IDT1200A, IDT1500A AND IDT1900A.

INDIGO[®] NXT

Modular Icemakers

Manitowoc Ice machines lead the way with ENERGY STAR and CEE performance criteria. Commercial ice machines that have earned the ENERGY STAR are on average 15% more energy efficient than other models.

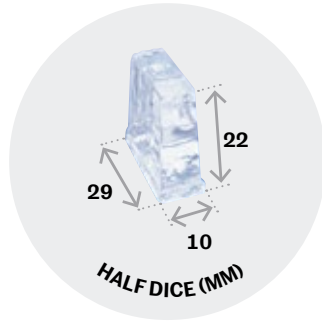

Indigo NXT Series Icemakers Modular Icemakers. Air cooled as standard. Available in Dice & Half Dice cube sizes.

Dice Indigo NXT Series Icemakers

CODE	PROD. 24 HRS	BIN OPTIONS	W X D X H
IDP0300A	142kg	D400	762 x 622 x 419mm
A IDP0320A	152kg	D320 or D420	558 x 622 x 546mm
IDP0620A	211kg	D320 or D420	558 x 622 x 546mm
IDP0500A	220kg	D400 or D570	762 x 610 x 546mm
IDP0600A	291kg	D400 or D570	762 x 622 x 546mm
IDP0800A	347kg	D570 or D970	762 x 622 x 673mm
IDT0900A	381kg	D570 or D970	762 x 622 x 673mm
IDP1000A	499kg	D570 or D970	762 x 622 x 749mm
IDT1200A	524kg	D570 or D970	762 x 622 x 749mm
IDT1500A	674kg	D970	1219 x 610 x 749mm
IDT1900A	819kg	D970	1219 x 622 x 749mm

SUPPLIED WITH NO PLUG OR CABLE AS STANDARD

Ice Storage Bins

CODE	STORAGE	W x D x H
D320	95kg	559 x 864 x 965mm
D400	132kg	762 x 864 x 965mm
B D420	141kg	559 x 864 x 1270mm
D570	195kg	762 x 864 x 1270mm
D970	323kg	1219 x 864 x 1270mm

Indigo NXT Series Accessories

CODE	DESCRIPTION
C AR-10000-P	Arctic Pure™ Water Filter for use with iT0300 - iT0750
AR-20000-P	Arctic Pure™ Water Filter for use with iT900
AR-40000-P	Arctic Pure™ Water Filter for use with iT1200 - iT1900
K00464	LuminIce II Growth Inhibitor kit for IT420 - IT1200
K00465	LuminIce II Growth Inhibitor kit for IT1500 - IT1900
K00470	Bin Adaptor Kit when using IDT0500A - IDT1200A w/D970
934009-G1	Installation Kit
K00VCMA-Kit	Drain Pump Kit

Half Dice Indigo NXT Series Icemakers

CODE	PROD. 24 HRS
IYP0300A	137kg
IYP0320A	145kg
IYP0620A	244kg
IYP0500A	236kg
IYP0600A	287kg
IYP0800A	331kg
IYT0900A	378kg
IYP1000A	504kg
IYT1200A	544kg
IYT1500A	674kg
IYT1900A	819kg

FOR TOP AIR DISCHARGE KITS VISIT FEM.CO.UK



OPPOSITE AR-10000-P WATER FILTER - HIGHLY RECOMMENDED FOR USE WITH ALL ICE MACHINES.

M Series Modular Icemakers

Affordable reliability.

Whether you're starting a new restaurant, needing to replace an existing ice machine, or deciding to add an additional ice machine to your operation. M Series modular ice machines provide you with the essential features that you need with the reliability you expect at a price that fits your budget.



ICEMAKING

M series ice machines are designed from the ground up to meet your operational demands for a worry-free, simple-to-use, essential ice machine; but that doesn't mean it cuts corners on quality. Instead, it uses a combination of engineering experience and manufacturing expertise to create an affordable, reliable ice machine at a price that's well within reach.

Easy to use

- There are only three controls: on, off and clean.

Easy to clean

- Access to evaporator and food zone is simple with the removal of just two screws and the opening of the hinged door.

Easy to maintain

- Parts that need cleaning can be removed without tools. The water shield, distribution tube, pump floats and even the trough can be removed by hand.

M Series Ice Makers Modular Icemakers. Air cooled as standard. Available in Dice & Half Dice cube sizes.

CODE	PROD. 24 HRS	ICE TYPE	BIN	W X D X H
MDP0700A	281kg	Dice	D570	762 x 622 x 456mm
MYP0700A	293kg	Half Dice	D570	762 x 622 x 456mm

 SUPPLIED WITH NO PLUG OR CABLE AS STANDARD



MDP0700A
SHOWN ON
D570

new

ICE STORAGE BINS
PAGE 117

Ice Machine Filtration

Ice is 100% water. As such, it might contain high TDS, chlorine, tannins or high iron levels. A properly sized water filtration system not only provides better tasting and good-looking ice, but also protects your equipment making it more reliable, efficient and cost effective.

- High TDS can cause misshapen, cloudy, soft and quick-melting ice.
- Chlorine and decaying organic material can give ice an unpleasant taste and odour.
- Tannins affect colour and clarity.
- High iron levels can promote slime buildup inside machine, parts and bin.



ICEMAKING

Pre-Coat Media Ice Filtration Systems

- Delivers premium quality water for ice applications.
- Micro-Pure II media with Agion antimicrobial protection inhibits any potential bacterial growth.
- Reduces water-related ice machine problems caused by scale build-up from dirt and dissolved minerals.
- Reduces maintenance and service costs by reducing scale and clogging of distribution lines, evaporator plate and pump.
- Precoat submicron technology reduces dirt and particles as small as 1/2 micron in size.



Pre-Coat Media Ice Filtration Systems

CODE	DESCRIPTION	SUITABLE USE
IS961224	I500 ² Complete System	Cubers < 85kg, Flakers < 145kg
EV932401	I2000 ² Complete System	Cubers < 255kg, Flakers < 435kg
EV961224	I500 ² Replacement Cartridge	
EV961227	I2000 ² Replacement Cartridge	

Fibredyne Ice Filtration Systems

- Features Fibredyne™ high effectively inhibits the growth of bacteria on the filter media.
- Fibredyne™ Reduces chlorine taste and odour and other offensive contaminants that can adversely affect the taste of beverages.
- Submicron filtration technology reduces dirt and particles as small as 1/2-micron in size.
- certified to reduce cysts such as Cryptosporidium and Giardia.
- Sanitary cartridge replacement is simple quick and clean.

Fibredyne Ice Filtration Systems

CODE	DESCRIPTION	SUITABLE USE
IS969176	2FC-S Complete System	Cubers < 170kg, Flakers < 290kg
EV920281	4FC-S Complete System	Cubers < 425kg, Flakers < 725kg
EV969176	2FC-S Replacement Cartridge	
EV969231	4FC-S Replacement Cartridge	



Featured Brands



Refrigeration

Our new refrigeration range delivers reliable, energy-efficient, and high-performance cooling solutions for commercial kitchens, bars, cafés, and hospitality environments. From undercounter and upright refrigerators and freezers to blast chillers and wine coolers, we have every aspect of your cooling needs covered. Featuring leading brands such as Gram Professional, renowned for durable, energy-efficient refrigeration with precise temperature control designed to perform to the highest standard. With robust construction, versatile storage options, and low-maintenance operation, Gram Professional refrigerators provide a trusted solution for any catering or hospitality environment.



Compact Cabinets	122
Maxi Cabinets	124
Bakery Cabinets	126
Gastro Counters	127
Blast & Shock Chillers	128
Dolomiti Blast Chillers	129
Meat Ageing Fridges	130
Wine Coolers	131

Compact Cabinets

Introducing the G+ Compact series: energy-efficient and dependable refrigerators and freezers crafted to excel in demanding kitchen environments.

- Professional refrigeration system with automatic defrost and fast temperature recovery.
- Food safety is ensured through a unique air distribution system that guarantees the temperature remains even throughout the cabinet.
- The units only use compressors where needed, one of the features which results in their low power consumption.
- Compact 200 units can be stacked to provide more usable space within the same small footprint.
- Reversible right-hand hinged door with full length ergonomic handle and lock.
- Electronic controls with safety functions for optimal product protection.
- Robust wire shelves with anti-tilt rails.

Compact 200 Refrigerators & Freezers

The Compact 200, with its small footprint and low height, fits almost anywhere. With low noise emissions, it is ideal for placement under counter tops in kitchens, bars and cafes where space is limited. Constructed from a durable ABS inside and a stainless steel or white outer. The display refrigerator features a glass door with integrated LED light and can be used as a display cabinet for quality products that require a stable temperature.



REFRIGERATION



R200 S



GR200 S



F200 W

Optional:

- S/S wire shelves
- S/S perforated wire shelves
- Left-hinged door
- Alternate legs or castors
- Wall mounting kit
- Foot pedal

Available for 200, 400 & 600 refrigerators and freezers.



Compact 200 Refrigerators Temperature range +2°C / +12°C.
Gross Volume 128L. Net Volume 78L.

CODE	DOOR	POWER	W x D x H
R200 S	St. Steel / Solid	0.062kw	595 x 642 x 830mm
R200 W	White / Solid	0.062kw	595 x 642 x 830mm
GR200 S	St. Steel / Glass	0.077kw	595 x 667 x 830mm
GR200 W	White / Glass	0.077kw	595 x 667 x 830mm

Compact 200 Freezers Temperature range -22°C / -5°C.
Gross Volume 128L. Net Volume 78L.

CODE	DOOR	POWER	W x D x H
F200 S	St. Steel / Solid	0.12kw	595 x 642 x 830mm
F200 W	White / Solid	0.12kw	595 x 642 x 830mm

*ALL MODELS SUPPLIED WITH  13A PLUG.



Compact Cabinets



MADE IN DENMARK
IN THE ORIGINAL FACTORY



Compact 400 Refrigerators & Freezers

The Compact 400 model is 190cm tall with a small footprint, making it highly versatile and able to fit most standard kitchen layouts. With low noise emissions, it is ideal for placement in staff kitchens, bars and cafes where space is limited. Sturdy stainless steel construction inside and out. The display refrigerator features a glass door with integrated LED light and can be used as a display cabinet for quality products that require a stable temperature.

Compact 400 Refrigerators Temperature range +2°C / +12°C. Castors as standard. Gross Volume 359L. Net Volume 266L.

CODE	DOOR	POWER	W x D x H
R400 S	St. Steel / Solid	0.088kw	595 x 642 x 1903mm
R400 W	White / Solid	0.088kw	595 x 642 x 1903mm
GR400 S	St. Steel / Glass	0.103kw	595 x 667 x 1903mm
GR400 W	White / Glass	0.103kw	595 x 667 x 1903mm

Compact 400 Freezers Temperature range -22°C / -5°C. Castors as standard. Gross Volume 359L. Net Volume 266L.

CODE	DOOR	POWER	W x D x H
F400 S	St. Steel / Solid	0.151kw	595 x 642 x 1903mm
F400 W	White / Solid	0.151kw	595 x 642 x 1903mm

*ALL MODELS SUPPLIED WITH 13A PLUG.



REFRIGERATION

Compact 600 Refrigerators & Freezers

The Compact 600 is the ideal cabinet for kitchens working with GN measurements, but where height is limited, and most standard GN refrigerators and freezers don't fit. With a height below 2 meters and space for GN containers 2/1 in depth, the Compact 600 fits perfectly and helps maximise the use of available kitchen space. Sturdy stainless steel construction inside and out.

Compact 600 Refrigerators Temperature range +2°C / +12°C. Castors as standard. Gross Volume 580L. Net Volume 421L.

CODE	DOOR	POWER	W x D x H
R600 S	St. Steel / Solid	0.261kw	695 x 868 x 2003mm
GR600 S	St. Steel / Glass	0.276kw	695 x 868 x 2003mm

Compact 600 Freezers Temperature range -22°C / -5°C. Castors as standard. Gross Volume 580L. Net Volume 421L.

CODE	DOOR	POWER	W x D x H
F600 S	St. Steel / Solid	0.398kw	695 x 868 x 2003mm

*ALL MODELS SUPPLIED WITH 13A PLUG.



GN 1/1
GN 1/1



Maxi Cabinets

In a professional kitchen, the pace is fast, and demands are high, so refrigeration equipment must be reliable, efficient and easy to handle - every day. The maxi range is designed to thrive in the toughest environments, where reliability and durability are a must, even with frequent door openings and high demands for temperature stability.

REFRIGERATION

- Designed for those who need a deep cabinet, the unique dimension of the Maxi units allows for two standard GN 1/1 containers in depth.
- GN containers can be placed on shelves or directly on the support rails with an anti-tilt function.
- The chiller features an extended temperature range, providing greater flexibility when compared to a refrigerator.
- Innovative and user-friendly controls ensure optimal operation and low energy consumption.
- Ergonomic design with a full-length door handle and a self-closing, reversible right-hand hinged door with lock.
- Rounded corners and removable magnetic door gaskets ensure optimal hygiene.
- Stainless steel interior and exterior.
- Efficient LED lighting.



Maxi Eco 700 Chiller & Freezer

Maxi Eco 700 Chiller Temperature range -2°C / +8°C. Castors as standard.

CODE	VOLUME (L)	POWER	W x D x H
ECO C700	610 Gross / 454 Net	0.198kw	700 x 895 x 2118mm

Maxi Eco 700 Freezer Temperature range -10°C / -23°C. Castors as standard.

CODE	VOLUME (L)	POWER	W x D x H
ECO F700	610 Gross / 454 Net	0.374kw	700 x 895 x 2118mm

*ALL MODELS SUPPLIED WITH 13A PLUG.



- Optional:**
- Additional wire shelves and support rails.
 - Stainless steel wire shelves.
 - Perforated shelves.
 - Left-hinged door.
 - Adjustable legs.

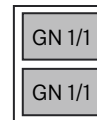

Maxi Cabinets



MADE IN DENMARK
IN THE ORIGINAL FACTORY



Maxi Superior 700 Chiller & Freezer

Superior 700 is Gram Professional's top-of-the-range series, combining market-leading energy efficiency with high cooling capacity and operational reliability and a long service life. With an annual energy consumption of only 278 kWh, the cabinet delivers best-in-class performance without compromise.

Maxi Superior 700 Chiller Temperature range -5°C / +12°C. Castors as standard.

CODE	VOLUME (L)	POWER	W x D x H
SUPERIOR C700	610 Gross / 454 Net	0.198kw	700 x 895 x 2118m

Maxi Superior 700 Freezer Temperature range -5°C / -25°C. Castors as standard.

CODE	VOLUME (L)	POWER	W x D x H
SUPERIOR F700	610 Gross / 454 Net	0.374kw	700 x 895 x 2118m

*ALL MODELS SUPPLIED WITH 13A PLUG.

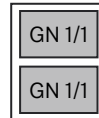

Optional:

- Additional wire shelves and support rails.
- Stainless steel wire shelves.
- Perforated shelves.
- Left-hinged door.
- Adjustable legs.



OPTIMISED REFRIGERATION SYSTEM AND 'BEST IN CLASS' ENERGY PERFORMANCE AND RELIABILITY



PRACTICAL PEDAL DOOR OPENER

REFRIGERATION

Maxi 650 Midi Chiller, Freezer & Display Refrigerator

The 650 Midi is specifically designed to fit into professional kitchen environments where efficiency and ergonomics are crucial. With a maximum height of just two metres and a depth of 775mm, it can be positioned easily even in areas with low ceilings or narrow passages. With the compressor located under the cabinet, extra storage space is available at a user-friendly height.

Maxi 650 Midi Chiller Temperature range -5°C / +12°C.

CODE	VOLUME (L)	POWER	W x D x H
MIDI C650	603 Gross / 456 Net	0.234kw	820 x 775 x 2000mm

Maxi 650 Midi Freezer Temperature range -25°C / -5°C.

CODE	VOLUME (L)	POWER	W x D x H
MIDI F650	603 Gross / 456 Net	0.398kw	820 x 775 x 2000mm

Maxi 650 Midi Display Refrigerator Temperature range +2°C / +12°C.

CODE	VOLUME (L)	POWER	W x D x H
MIDI GR650	603 Gross / 456 Net	0.260kw	820 x 775 x 2000mm

*ALL MODELS SUPPLIED WITH 13A PLUG.

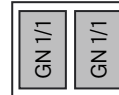

C650 MIDI



GR650 MIDI



Maxi Cabinets

Visit FEM.CO.UK for our full range which includes...

G+
GRAM
PROFESSIONAL



MADE IN
DENMARK
IN THE ORIGINAL FACTORY

new

REFRIGERATION



MAXI C510 EURO
MAXI F510 EURO



MAXI C710 TWIN
MAXI F710 TWIN



MAXI C1400 PLUS
MAXI F1400 PLUS



MAXI C1200 ROLL-IN
MAXI F1200 ROLL-IN

Bakery Cabinets

Professional refrigeration equipment for the bakery.



Storage Cabinets

Storage cabinets are available as either a refrigerator with extended refrigeration (chiller) or as a freezer and feature low operating costs, high temperature stability and an easy-clean design.



Retarder Provers

Durable and reliable retarder provers with versatile applications, built for professional use. Equipped with electronic controls boasting standard and customisable programs, ergonomic door handles and an easy-to-maintain stainless steel surface.



Shock Freezers

Professional shock-freezers of the highest quality, tailored for daily use in the bakery. Quickly and efficiently cool or freeze your food and ensure that the quality of the food is preserved.

Gastro Counters

In busy commercial kitchens, efficiency and clever organisation are essential. With gastro counters, you can effortlessly access your prepped items, garnishes and add-ons without having to move away from your work zone.

- Designed to be placed directly against a wall, under a tabletop, on a plinth or as a standalone unit.
- Doors are easy to open and close, inside are anti-tip shelf rails, which ensure you can handle your ingredients safely.
- Chillers provide an extended temperature range when compared to refrigerators, making them more flexible to the needs of professional kitchens.
- Rounded corners and removable magnetic door gaskets make it easy to clean and maintain excellent hygiene.
- Sturdy stainless steel construction inside and out.
- 50mm insulated tabletop as standard.
- Reversible self-closing doors with ergonomic handles.



MADE IN DENMARK
IN THE ORIGINAL FACTORY



TWO STAINLESS STEEL WIRE SHELVES PER SECTION



F2



C3



C4

Gastro Counter Chillers Temperature range -5°C / +12°C.
Castors as standard.

CODE	DOORS	VOLUME (L)	POWER	W x D x H
C2	2	345 Gross / 255 Net	0.207kw	1289 x 700 x 878mm
C3	3	506 Gross / 397 Net	0.214kw	1726 x 700 x 878mm
C4	4	668 Gross / 539 Net	0.218kw	2163 x 700 x 878mm

Gastro Counter Freezers Temperature range -25°C / -5°C.
Castors as standard.

CODE	DOORS	VOLUME (L)	POWER	W x D x H
F2	2	345 Gross / 255 Net	0.384kw	1289 x 700 x 878mm
F3	3	506 Gross / 397 Net	0.391kw	1726 x 700 x 878mm
F4	4	668 Gross / 539 Net	0.437kw	2163 x 700 x 878mm

*ALL MODELS SUPPLIED WITH  13A PLUG.

Customise to fit your kitchen's requirements.

Optional:

- Drawers: 1/2 or 1/3 size (chillers only)
- Tabletop: flat, 50mm backsplash, insulated top
- Alternative leg or castor sizes
- Electric elevation system
- Stainless steel perforated shelves
- Remote installation



Blast & Shock Chillers



MADE IN DENMARK
IN THE ORIGINAL FACTORY



Roll-In Blast Chiller

A powerful roll-in blast chiller with a capacity of up to 60kg. With a robust design, electronic control and CO₂ compatibility, the BC50 is a reliable choice for commercial kitchens that need fast and safe cooling in an efficient working environment.

- The cooldown process is controlled by the included food probe.
- Can be placed on the floor, so trolleys can be rolled directly into the cabinet.
- Powerful fans and an efficient evaporator ensure optimal cooling.
- Robust stainless steel construction inside and out.
- Right-hand hinged door with lock and snap handle as standard.
- Optional: water-cooled condenser, remote installation, adaptation set for Rational SCC/CPC 201 and COMBI 20 1/1, heated bottom plate.



Roll-In Blast Chiller Temperature range -25°C / +10°C.

CODE	VOLUME (L)	MAX CAPACITY	POWER	W X D X H
BC50	Gross 970 / Net 630	60kg	3kw	780 x 1030 x 2215mm

*SUPPLIED WITH 13A PLUG.

Shock Chillers

A versatile choice for kitchens that require both refrigeration and freezing capabilities along with extra storage space - without compromising on quality or control.

- Three different cooling programs - timed, hard and gentle - means the kitchen has full control over food safety and quality.
- Can be used for defrosting, chilling or freezing with temperatures ranging from -30°C to +10°C, making it ideal as a flexible backup solution during busy periods.
- Once planned cooling is complete, the cabinet automatically returns to store the product at the set temperature.
- Powerful fans and an efficient evaporator.
- 5 stainless steel wire shelves included.
- Effective LED lighting.
- Pedal door opener.
- Adjustable legs 135 / 200mm.
- Optional: remote installation.



Shock Chiller Temperature range -30°C / +10°C.

CODE	VOLUME (L)	MAX CAPACITY	POWER	W X D X H
SC500	Gross 465 / Net 319	25kg	1.025kw	600 x 855 x 2125mm
SC710	Gross 614 / Net 451	50kg	1.523kw	820 x 785 x 2125mm

*ALL MODELS SUPPLIED WITH 13A PLUG.

Dolomiti Blast Chillers

- Designed for blast chilling/freezing fresh or prepared foods.
- Simple to operate with easy to use controls.
- Control temperature with core probe provided or adjust temperature manually.
- Blast chilled to +3 in 90 minutes.
- Shock frozen to -18 in 240 minutes.
- Blast freezing/chilling programmes and hold function.
- Stainless steel construction.
- Dolomiti 7, 10 and 14 models come with SOFT freezing programme.

SPACE-SAVING TOP CAN BE USED AS A WORKING SURFACE



DOLOMITI 2/3
CHILL 8KG IN 90 MINUTES
FREEZE 5KG IN 240 MINUTES



DOLOMITI 7 GELATERIA
CHILL 20KG IN 90 MINUTES
FREEZE 12KG IN 240 MINUTES

Dolomiti 3

CODE	POWER	PLUG	CAP GN	WxDxH
DOLOMITI 2/3	0.65kw	13A	29L 3 x 2/3	640 x 630 x 400mm
DOLOMITI 3	0.79kw	13A	36L 3 x 1/1	640 x 740 x 500mm

Dolomiti 7 Gelateria

CODE	POWER	PLUG	CAP GN	WxDxH
DOLOMITI 7	1.49kw	13A	150L 7 x 1/1	1300 x 700 x 830mm



DOLOMITI 5
CHILL 12KG IN 90 MINUTES
FREEZE 9KG IN 240 MINUTES



DOLOMITI 10 GELATERIA
CHILL 25KG IN 90 MINUTES
FREEZE 15KG IN 240 MINUTES



DOLOMITI 14 GELATERIA
CHILL 40KG IN 90 MINUTES
FREEZE 25KG IN 240 MINUTES

Dolomiti Blast Chillers

CODE	POWER	PLUG	CAPACITY GN	WxDxH
DOLOMITI 5	1.02kw	13A	95L 5 x 1/1	750 x 750 x 880mm
DOLOMITI 10	1.775kw (3PH)	16A	206L 10 x 1/1	750 x 750 x 1500mm
DOLOMITI 14	3.4kw (3PH)	16A	282L 14 x 1/1	750 x 750 x 1900mm

*DOLOMITI 10 AND 14 MODELS ARE 3 PHASE SUPPLY

Meat Ageing Fridges

The Sirman Kairos meat ageing fridge provides the perfect climate to cure, preserve and season your meat products.

- Maximum accessibility to components for easy maintenance.
- Temperature: 2°C/25°C.
- Humidity: 40-95%.
- Standard humidity injection pump with 5 Lt tank and level sensor.
- Programmable UV lamp.
- Controllable internal fan speed 10-100%.
- Empty water tank alarm.
- Easy and intuitive free APP, Wi-Fi capabilities.
- Internal ventilation.
- Removable back panel for easy cleaning.

new



REFRIGERATION



WITH CURED MEAT KIT
INCLUDES 2 CROSSBARS AND 8 HANGERS



WITH MEAT MATURATION KIT
INCLUDES 3 WIRE SHELVES



EASY AND INTUITIVE FREE APP



PRACTICAL AND ELEGANT HANDLE



REMOVABLE BACK PANEL FOR
EASY CLEANING

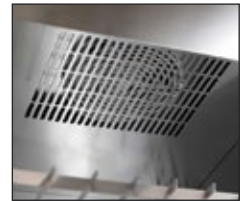

INTERNAL VENTILATION

Meat Ageing Fridges

CODE	DESCRIPTION	POWER	W X D X H
KAIROS CURER	Fridge With Cured Meat Kit	0.57kw	725 x 797 x 2050mm
KAIROS AGER	Fridge With Meat Maturation Kit	0.57kw	725 x 797 x 2050mm

*ALL MODELS SUPPLIED WITH  13A PLUG.

Wine Coolers

An elegant wine storage solution for bars, restaurants and hotels. Store up to 182 bottles at the perfect temperature with single and dual temperature zones.

- Door with UV protected, double tempered glass.
- Key lock system for added security.
- Easy-to-use digital touch controls.
- Thermostat adjustable in °C or °F.
- LED display and interior light.
- Auto-defrost and active carbon filter.
- Interior fan.
- Noise level 40 decibels.
- Conero is a built-in model. Built-in and semi built-in optional for Pantelleria, Salento and Soave.



BUILT-IN MODEL NEATLY FITS INTO COUNTERS. HOLE SIZE REQUIRED 565 X 540 X 450MM.

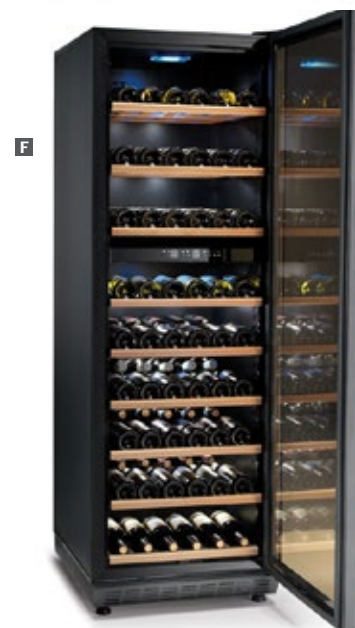

REFRIGERATION

Wine Coolers

CODE	TEMPERATURE ZONES	TEMPERATURE (°C)	CAPACITY	POWER	W X D X H
A PANTELLERIA	1	5 - 18	16 Bottles (49L)	0.07kw	398 x 410 x 565mm
B CONERO	1	5 - 18	24 Bottles (53L)	0.075kw	595 x 600 x 455mm
C SALENTO	1	5 - 18	51 Bottles (150L)	0.12kw	595 x 575 x 850mm
D SOAVE	2	5 - 12, 12 - 18	51 Bottles (150L)	0.12kw	595 x 575 x 850mm
E COLLI	2	5 - 12, 12 - 18	96 Bottles (270L)	0.15kw	595 x 590 x 1640mm
F MONFERRATO	2	5 - 12, 12 - 18	182 Bottles (450L)	0.16kw	595 x 760 x 1800mm

*ALL MODELS SUPPLIED WITH  13A PLUG.

Featured Brands

CAMBRO
TRUSTED DURABILITY

SIRMAN

winco

WOLLRATH

Warewashing

Maintaining cleanliness and hygiene is essential in any commercial kitchen or foodservice operation. Clearing, washing, transporting, and storing dishes and glassware requires practical, space-saving solutions to prevent breakages and streamline workflows. From undercounter and pass-through warewashers to the complete Camrack washing and storage system, our easy-to-use products save time, money, and resources, delivering safe, efficient, and reliable warewashing solutions for kitchens of any size.



CX WASH Warewashers	134
HP WASH Warewashers	134
OSMO ₃ Warewashers	136
Electric Glass Washer	137
Electric Glass Polisher	137
Camrack®	
Full Size Glass Racks	139
Honeycomb Glass Racks	139
Camdolly & Cover	140
Base Racks	140
Cup Racks	140
Peg, Tray & Flatware Racks	140
Flatware Baskets	141
Cutlery Cylinders	141
Bussing Boxes	141

Sirman Warewashing Solutions



WAREWASHING

A comprehensive range of professional warewashing equipment, including undercounter and pass-through hood machines.

The lineup features the simple and dependable CX WASH, the HP WASH with enhanced functionality such as custom wash cycles and an advanced display and the innovative OSMO3.



CX WASH Undercounter Warewashers

- Compact line of stainless steel glasswashers and dishwashers.
- AISI 304 stainless steel tank.
- Electronic rinse aid dispenser included.
- New in-tank filtration system.
- Provision for an external detergent dispenser included.
- Stainless steel impellers.
- Electronic board featuring: 3 programs, booster heater (temp adjustable from 65°C to 85°C) , tank water temp adjustment from 40°C to 60°C, detergent quantity and rinsing agent quantity.



CX WASH 35 SUITABLE FOR RACKS 350 X 350MM
CX WASH 40 SUITABLE FOR RACKS 400 X 400MM

CX WASH Undercounter Warewashers

CODE	DESCRIPTION	TANK CAP	POWER	PLUG	WXDXH
CX WASH 35 GLASS	Glasswasher	8.5L	2.25kw	13A	450 x 450 x 600mm
CX WASH 40 GLASS	Glasswasher	8.5L	2.25kw	13A	480 x 480 x 600mm

HP WASH 40 Undercounter Warewasher

- Compact front-loading design fits perfectly into smaller spaces.
- Suitable for use with 400x400mm racks.
- Custom washing times and personalised functions.
- Maximum tableware height 290mm.
- Double display with temperature view.
- Electric rinse aid pump.
- Stainless steel rinse jet.
- 5 wash cycles.



HP WASH 40 Undercounter Warewasher

CODE	DESCRIPTION	TANK CAP	POWER	PLUG	WXDXH
A HP WASH 40 GLASS	Glasswasher	6.5L	3.25kw	16A	495 x 520 x 640mm



HP WASH 50 Undercounter Warewasher

- Compact front-loading design fits perfectly into smaller spaces.
- Suitable for use with 500x500mm racks.
- 5 washing times and personalised functions.
- Maximum tableware height 350mm.
- Double display with temperature view.
- Electric rinse aid pump.
- Stainless steel rinse jet.
- 5 wash cycles.



HP WASH 50 Undercounter Warewasher

CODE	DESCRIPTION	TANK CAP	POWER	PLUG	WXDXH
HP WASH 50 GLASS	Glasswasher	21L	3.9kw	16A	600 x 600 x 825mm
HP WASH 50 DISH	Dishwasher	21L	3.9kw	16A	600 x 600 x 825mm

HP WASH 50H Pass-Through Warewasher

- Perfectly suited to busy commercial kitchens and able to accommodate a constant flow of glasses and dishes.
- Glasses and dishes can be loaded on one side and unloaded on the other without interrupting workflow.
- Suitable for use with 500x500mm racks.
- 5 washing times and personalised functions.
- Maximum tableware height 400mm.
- Electric rinse-aid pump.
- Stainless steel rinse jet.
- Easy maintenance.
- Washtank filter.



SHOWN WITH
STAINLESS
STEEL TABLES.
NOT INCLUDED.

HP WASH 50H Pass-Through Warewasher

CODE	DESCRIPTION	TANK CAP	POWER	PLUG	WXDXH
HP WASH 50H GLASS	Glasswasher	27L	7kw (3PH)	32A	775 x 710 x 1895mm
HP WASH 50H DISH	Dishwasher	27L	7kw (3PH)	32A	775 x 710 x 1895mm

HP WASH 60H Pass-Through Warewasher

- 5 washing programmes.
- Maximum tableware height 400mm.
- Maximum basket size 600x500mm.
- Customisable functions.
- Double display with temperatures.
- Electric rinse-aid pump and stainless steel rinse jet.
- Easy maintenance and front accessibility.
- Deep-drawn tank and insulated boiler.
- Washtank filter.



LARGE CHAMBER
SUITABLE FOR
600 X 400MM
BAKERY PANS &
1/1 GN PANS

HP WASH 60H Pass-Through Warewasher

CODE	DESCRIPTION	TANK CAP	POWER	PLUG	WXDXH
HP WASH 60H GLASS	Glasswasher	27L	7kw (3PH)	16A	775 x 710 x 1450mm
HP WASH 60H DISH	Dishwasher	27L	7kw (3PH)	16A	775 x 710 x 1450mm

OSMO₃ Warewashers

Designed to deliver exceptional cleanliness and hygiene, the OSMO₃ uses ozone and osmosis technology to remove all residues and impurities from the water, ensuring outstanding dishwashing results every time.

FIGHTS INFECTIOUS OR PATHOGENIC MICROORGANISMS

Ozone is a powerful sanitising agent with oxidising properties capable of **eliminating 99%** of a wide range of microorganisms, including bacteria, moulds, fungi and inactivating viruses present in water, air and on surfaces.

NEUTRALISES BAD ODOURS

Ozone ensures **effective and long-lasting deodorisation** through an oxidation process that breaks down volatile organic molecules responsible for unpleasant odours.

PROTECTS THE ENVIRONMENT

Ozone, through a natural oxidation process, **provides effective disinfection without the use of chemicals**. At the end of the treatment, it spontaneously decomposes into molecular oxygen. **Leaving no harmful residues for the environment or health.**

OSMO₃ 40 Undercounter Warewasher

- Minimal and compact design, perfect for small spaces.
- Soft closing door with no visible screws and a double side wall for greater efficiency.
- Integrated reverse osmosis with continuous operation for fast drying without streaks.
- Integrated ozone air and water sanitation allows for low temperature washes and anti-odour.
- 65% savings on detergents and rinse aids.
- Suitable for use with 400x400mm racks.
- Maximum tableware height 290mm.

OSMO₃ 40 Undercounter Warewasher

CODE	DESCRIPTION	TANK CAP	POWER	PLUG	W X D X H
OSMO3 40 GLASS	Glasswasher	6.5L	3.65kw	16A	500 x 540 x 725mm



new

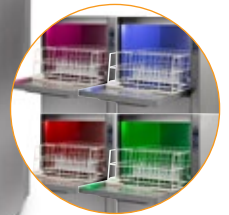

DISPLAY AND INTERNAL LEDS AVAILABLE IN 9 COLOURS.

OSMO₃ 50 Undercounter Warewasher

- Minimal and compact design, perfect for small spaces.
- Soft closing door with no visible screws and a double side wall for greater efficiency.
- Integrated reverse osmosis with continuous operation for fast drying without streaks.
- Integrated ozone air and water sanitation allows for low temperature washes and anti-odour.
- 65% savings on detergents and rinse aids.
- Suitable for use with 500x500mm racks.
- Maximum tableware height 350mm.



OSMO₃ 50 Undercounter Warewasher

CODE	DESCRIPTION	TANK CAP	POWER	PLUG	W X D X H
OSMO3 50 GLASS	Glasswasher	10L	5.65kw	16A	600 x 640 x 825mm
OSMO3 50 DISH	Dishwasher	10L	5.65kw	16A	600 x 640 x 825mm

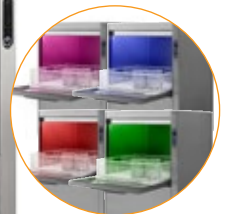

DISPLAY AND INTERNAL LEDS AVAILABLE IN 9 COLOURS.

OSMO3 50H Pass-Through Warewasher

Hood-type dishwasher perfectly suited to busy commercial kitchens and able to accommodate a constant flow of glasses and dishes. The unit can be loaded on one side and unloaded on the other without interrupting workflow.

- Integrated reverse osmosis ensures fast drying without streaks and protects the machine from daily wear and tear.
- Integrated ozone air / water sanitization allows the machine to wash at low temperatures and provides anti-odour for glasses, dishes and the machine's interior.
- 65% savings on detergents and rinse aids.
- Suitable for use with 500x500mm racks.
- Maximum tableware height 400mm.



DISPLAY AND INTERNAL LEDS AVAILABLE IN 9 COLOURS.

WAREWASHING

OSMO3 50H Pass-Through Warewasher

CODE	DESCRIPTION	TANK CAP	POWER	PLUG	W X D X H
OSMO3 50H GLASS	Glasswasher	27L	10kw (3PH)	32A	710 x 775 x 1900mm
OSMO3 50H DISH	Dishwasher	27L	10kw (3PH)	32A	710 x 775 x 1900mm

BarMaid® Electric Glass Washer

- Five spinning brushes (four 6" brushes and one 6-3/4" centre brush) clean inside and out simultaneously for crystal clear glassware.
- Durable heavy-duty stainless steel construction built to withstand heavy use in demanding environments.
- Compact size means the glass washer is perfectly suited to businesses with limited space.
- Energy efficient helping businesses save on utility costs over time.
- Versatile unit which can accommodate various types and sizes of glassware, from wine glasses to pint glasses.
- Quiet, powerful 1/3 HP enclosed motor with sealed lower bearing and exclusive Splashguard canopy.
- Automatic overload safety and ground fault protection plug.

new



BarMaid® Electric Glass Washer

CODE	DESCRIPTION	PLUG	W X D X H
A-205-230	Upright Glass Washer	13A	203 x 305 x 450mm

BarMaid® Electric Glass Polisher

- On demand glassware polishing solution that saves on labour, replacement costs and injury claims.
- Efficient warm air flow dries just-washed glassware while polishing at the same time.
- Lint-free, sanitary solution which reduced unhygienic handling.
- Improved safety with low risk of breakage, reducing injury claims and glassware replacement costs.
- Compact footprint and lightweight with built-in handles.
- Polishing heads are soft, absorbent, removable and washable.

new



BarMaid® Electric Glass Polisher

CODE	DESCRIPTION	PLUG	W X D X H
GP-3MINI-CE	Upright Glass Polisher	13A	330 x 380 x 610mm

Camrack® System

The 4-in-1 solution for all your warewashing needs.
Work smarter, not harder!

It's time-consuming to transfer glassware and crockery from washing racks to storage racks, and what's more that's when breakages occur, streamline warewashing with the Camrack. This 4-in-1 system enables glassware and crockery to be washed, stored and transported in the same rack eliminating the need for extra handling, reducing the chances for breakages and significantly cutting down on staff time.

Camracks eliminate the need to rewash your glassware resulting in significant savings on electricity, water, chemicals, labour, and plastic film and help preserve our environment. Camracks offer an economical and environmentally-friendly warewashing solution that provides simplified and efficient workflows.

WAREWASHING



OPEN INSIDE COMPARTMENTS PROVIDE THOROUGH CIRCULATION OF WATER AND CLEANING SOLUTION AND PROMOTE QUICK AND THOROUGH DRYING.

EASY TO HANDLE WITH 13MM OVERLAP AND SMOOTH SIDES. THEY INTERSTACKABLE AND MEASURE 500 X 500MM AND CAN BE USED WITH MOST COMMERCIAL DISHWASHERS

EASY TO HANDLE EASY-TO-GRIP, ROUNDED HANDLES ON ALL FOUR SIDES, SMOOTH SIDES AND ROUNDED CORNERS REDUCE RISK OF INJURY.



FULLY ENCLOSED CLOSED SIDES AND COVER ELIMINATE THE NEED FOR REWASHING SAVING VALUABLE LABOUR, WATER AND CLEANING RESOURCES.

EXTREMELY DURABLE LONG-LASTING POLYPROPYLENE CAMRACKS® ARE BUILT TO WITHSTAND CHEMICALS AND HIGH TEMPERATURES UP TO 93°C.

FIND THE PERFECT FIT FULL-SIZE GLASS RACKS ARE AVAILABLE IN 7 DIFFERENT COMPARTMENT SIZES WITH A CHOICE OF 10 BASE RACK COLOURS. COVER AND DOLLY OPTIONAL.



Camrack® Full Size Glass Racks 500 x 500mm



FOR SUPPORT IN SIZING
THE RIGHT CAMRACKS
FOR YOUR GLASSWARE
CONTACT
SALES@FEM.CO.UK



MAX Ø
149MM



MAX Ø
111MM



MAX Ø
87MM



MAX Ø
73MM



MAX Ø
62MM

9 Compartment Rack

Max glass height (H).

9S318	H92mm
-	
9S434	H133mm
-	
9S638	H174mm
-	
9S800	H215mm
-	
9S958	H257mm
-	
9S1114	H298mm
-	

16 Compartment Rack

Max glass height (H).

16S318	H92mm
16S418	H114mm
16S434	H133mm
16S534	H155mm
16S638	H174mm
16S738	H196mm
16S800	H215mm
16S900	H238mm
16S958	H257mm
16S1058	H279mm
16S1114	H298mm
16S1214	H320mm

25 Compartment Rack

Max glass height (H).

25S318	H92mm
25S418	H114mm
25S434	H133mm
25S534	H155mm
25S638	H174mm
25S738	H196mm
25S800	H215mm
25S900	H238mm
25S958	H257mm
25S1058	H279mm
25S1114	H298mm
25S1214	H320mm

36 Compartment Rack

Max glass height (H).

36S318	H92mm
36S418	H114mm
36S434	H133mm
36S534	H155mm
36S638	H174mm
36S738	H196mm
36S800	H215mm
36S900	H238mm
36S958	H257mm
36S1058	H279mm
36S1114	H298mm
36S1214	H320mm

49 Compartment Rack

Max glass height (H).

49S318	H92mm
-	
49S434	H133mm
-	
49S638	H174mm
-	
49S800	H215mm
-	
49S958	H257mm
-	
49S1114	H298mm
-	

Honeycomb Glass Racks

A 20 Compartment Rack

Max glass height (H).

20S318	H92mm
20S418	H114mm
20S434	H133mm
20S534	H155mm
20S638	H174mm
20S738	H196mm
20S800	H215mm
20S900	H238mm
20S958	H257mm
20S1058	H279mm
20S1114	H298mm
20S1214	H320mm

B 30 Compartment Rack

Max glass height (H).

30S318	H92mm
30S434	H133mm
30S638	H174mm
30S800	H215mm
30S958	H257mm
30S1114	H298mm



To order a specific base rack colour add the colour code to the end of the item code.

BLACK 110	GREEN 119
GREY 151	RED 163
BROWN 167	BLUE 168
BEIGE 184	NAVY BLUE 186
TEAL 414	CRANBERRY 416

WAREWASHING



Camdolly & Camdolly with Handle Easily and safely transport Camrack® stacks. Dimensions 545 x 545 x 205mm. Dimensions w/ handle 545 x 595 x 940mm.

CDR2020	no handle
CDR2020H	w/ handle



Full Rack Cover Create a self contained sanitary storage system by covering top racks with Camrack® Covers.

DRC2020 500x500mm



Full Size Base Racks This durable rack holds pots, pans, bowls and other large preparation, service and display items. For Total Rack Height add 18mm to the inside rack height shown below (H).

BR258	H83mm
BR414	H124mm

Camrack® Cup Racks - 500 x 500mm Racks have a unique tilt feature that drains all water from cup and coffee mug bases, ensuring quick and sanitary drying.



16 Compartment Cup Rack
Compartment dimensions 111 x 111 x (H)mm.
Max cup height below.

16C258	H66mm
16C414	H107mm

20 Compartment Cup Rack
Compartment dimensions 111 x 88 x (H)mm.
Max cup height below.

20C258	H66mm
20C414	H107mm

Camrack® Full Size Peg, Tray & Flatware Racks

Standard 9 x 9 Peg Rack

Designed to wash varying sized plates, bowls, trays and plate covers.

Standard peg racks hold:

- Eighteen Ø254mm plates.
- Twelve Ø305mm plates.
- Twenty-seven Ø190mm plates.
- Nine 360 x 460mm trays.



Standard 9 x 9 Peg Rack

For Total Rack Height add 35mm to the Inside Rack Height shown below.

PR314	H83mm
-------	-------

5 x 9 Peg Rack

Designed to wash standard size plates when placed in one direction and deep-dish plates

The 5 spacing setup holds up to:

- Ten Ø254mm deep dish plates.
- The 9 spacing setup holds up to:
- Eighteen Ø254mm plates.
- Twelve Ø305mm plates.
- Nine 360 x 460mm trays.



5 x 9 Peg Rack

For Total Rack Height add 35mm to the Inside Rack Height shown below.

PR59314	H83mm
---------	-------

Open End Tray Rack

Open-ended on one side for easy placement and removal of trays of all lengths. Holds 9 trays upright.



Open End Tray Rack

For Total Rack Height add 35mm to the Inside Rack Height shown below.

OETR314	H83mm
---------	-------

Flatware Rack

Use to effectively soak and wash all flatware and utensils. The bottom is a durable mesh design that holds ALL types of flatware while allowing for water and cleaning solutions to pass easily through. Large 8 Compartment Basket fits into a full-size base rack.



Full Flatware Rack

For Total Rack Height add 35mm to the Inside Rack Height shown below.

FR258	H83mm
-------	-------

A Camrack® 8 Compartment Half Size Flatware Basket Effectively soak and wash all flatware and utensils. The bottom is a durable mesh design allowing water and cleaning solutions to easily pass through. Inside Rack Height 120mm. Outside Rack Height 184mm.

8FB434 w/ handles

8FBNH434 no handles

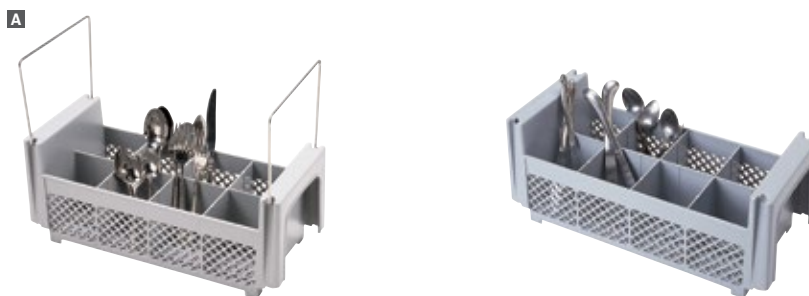

Flatware Vertical Holders

B FVVH-3B 146 x 260 x 540mm
3 high, includes
3 flatware cylinders

C FVVH-3X2B 284 x 260 x 562mm
Vertical holder
76 x 51mm includes
6 flatware holders

D CTFWH-8B 257 x 460 x 438mm
Countertop flatware
holder 102 x 51mm,
includes 8 flatware
cylinders

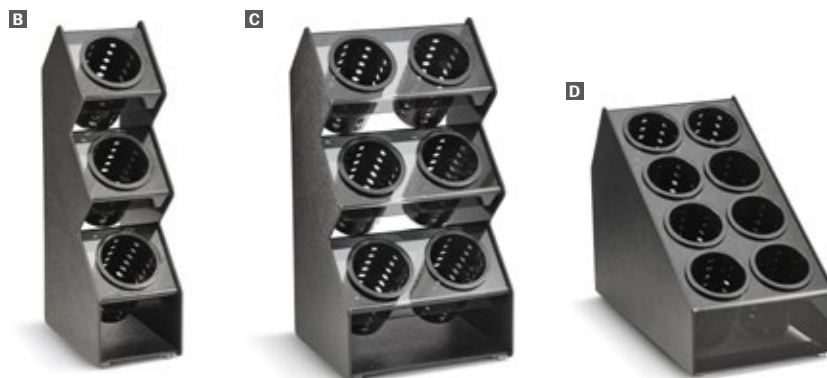

E Vollrath Cutlery Cylinders

Heavy-duty long-wearing construction. Ideal for final sanitisation and storage of flatware and other utensils. Ø95 x H143mm fits all Silv-A-Tainers.

99710 Stainless Steel

52643 Plastic - White



Cambox® Bussing Boxes

Whatever you use a dish box for, bussing, storing or transporting, the Polyethylene Cambox® is the economical high gloss plastic dish box that will provide long service with normal use and care.



Cambox® Four Compartment Cutlery Bussing Box

Durable polyethylene construction.

F 1120CBP 289 x 520 x H95mm

Cambox® Standard Bussing Boxes

Durable polyethylene construction. Available in four sizes. To order Black add 1.10 to the item code and for Grey add 180.

G 1520CBP 389 x 506 x H125mm

H 21155CBP 387 x 514 x H125mm

I 21157CBP 386 x 512 x H176mm

J 1722CBP 429 x 556 x H121mm

Featured Brands

CAMBRO
TRUSTED DURABILITY

pujadas
A VOLLRATH COMPANY

Shelving & Trolleys

Great storage is essential for any commercial kitchen. Your system needs to maximise space while remaining hard-wearing, hygienic, and versatile enough for use in kitchens, cold rooms, and freezers. Shelving is the foundation of effective storage - getting it right makes everything else easier. Our shelving systems are strong, easy to assemble, rust-free, corrosion-resistant, and simple to clean, ensuring the perfect solution for your kitchen. We also offer a wide range of multi-purpose trolleys for serving, storage, and organisation. Both our shelving and trolleys are built to the highest quality standards for reliable, long-term performance.





Camshelving®	
Basics Plus Starter Units	144
Basics Plus Add-On Units	145
Basics Plus Shelf Kits	145
Basics Plus Dunnage Stands	145
Elements Xtra Mobile Units	145
Premium Starter Units	147
Premium Add-on Units	147
Premium Shelf Kits	148
Premium Mobile Units	148
Dividers Bars & Shelves	149
Drying Racks	149
Dunnage Racks	149
Wall Shelves	149
Elevation Series Wall Shelving	150
Elevation Series Pegboards	151
Universal Storage Rack	152
Gastronorm Food Pan Trolleys	153
Baking Tray Trolleys	153
Catering Trolleys	154
Plate Trolley	155
Service Trolleys	155
Adjustable Dish Caddies	157

Camshelving® - Is BASICS PLUS or PREMIUM Right For You?

BASICS PLUS Series

PREMIUM Series

Frequency of Delivery	2-4 deliveries per week.	Frequent and/or multiple daily deliveries.
Durability	Can withstand constant loading and off-loading of light to medium products.	Can withstand constant loading and off-loading of medium to heavy products.
Assembly	Easy to assemble.	Moulded in dovetails means fewer parts, easiest to assemble.
Weight-Bearing Capacity	Can withstand up to 800kg per unit.	Can withstand up to 800kg per unit.
Construction	Composite material.	Strong steel core.
Styles	Starter and add-on units.	Starter, add-on and mobile units.

**ELEMENTS SERIES
MOBILE UNITS
AVAILABLE
SEE PAGE 145**

SHELVING & TROLLEYS



Camshelving® Basics Plus

Enjoy shelving for life with the unmatched durability and reliability of Basics Plus Camshelving. It allows operators to quickly and easily create the perfect configurations for dry storage and coolers, with a lifetime guarantee against rust and corrosion.

- Shelf plates easily wipe clean or fit through a commercial dishwasher.
- Antimicrobial protection permanently moulded into shelf plates.
- Vented shelves allow for maximum airflow around perishable products.
- Designed to share posts, simplifying assembly and maximizing storage space.

STARTER UNIT



EACH BASIC PLUS STARTER UNIT INCLUDES 2 POST KITS AND 4 SHELF KITS

ADD-ON UNIT



EACH BASICS PLUS ADD-ON UNIT INCLUDES 1 POST KIT AND 4 SHELF KITS

CORNER UNIT



CORNER CONNECTORS CAN BE USED TO BUILD CORNER AND U-SHAPE UNITS.

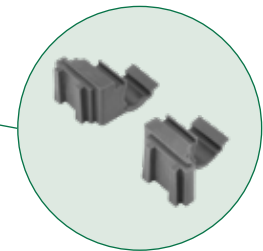

CORNER CONNECTORS

Corner Connectors

CBCC1 4 sets required per 4 tier unit

Camshelving® Basics Plus Starter Units

Camshelving® Basics Plus Starter Units 4-Tier 1830mm high with vented shelves as standard.

WIDTH	DEPTH 460MM	DEPTH 610MM
765mm	CBU183072V4	CBU243072V4
915mm	CBU183672V4	CBU243672V4
1070mm	CBU184272V4	CBU244272V4
1220mm	CBU184872V4	CBU244872V4
1375mm	CBU185472V4	CBU245472V4
1525mm	CBU186072V4	CBU246072V4



Camshelving® Basics Plus Add-On Units

Camshelving® Basics Plus Add-On Units 4-Tier 1830mm high with vented shelves.

WIDTH	DEPTH 460MM	DEPTH 610MM
735mm	CBA183072V4	CBA243072V4
885mm	CBA183672V4	CBA243672V4
1040mm	CBA184272V4	CBA244272V4
1190mm	CBA184872V4	CBA244872V4
1345mm	CBA185472V4	CBA245472V4
1495mm	CBA186072V4	CBA246072V4



Camshelving® Basics Plus Shelf Kits

Each shelf kit includes 2 traverses, dovetails and shelf plates.

Camshelving® Basics Plus Shelf Kits Made from strong composite and plastic materials. Wipes clean. Rust Proof.

WIDTH	DEPTH 460MM	DEPTH 610MM
765mm	CBSK1830V1	CBSK2430V1
915mm	CBSK1836V1	CBSK2436V1
1070mm	CBSK1842V1	CBSK2442V1
1220mm	CBSK1848V1	CBSK2448V1
1375mm	CBSK1854V1	CBSK2454V1
1525mm	CBSK1860V1	CBSK2460V1



Camshelving® Basics Plus Dunnage Stands

Increase weight bearing capacity on the bottom shelf of your unit.

CODE	DESCRIPTION	DIMENSIONS
CBDS18H6	Low	460 x 171mm
CBDS24H6	Low	610 x 171mm
A CBDS18H10	Tall	460 x 273mm
CBDS24H10	Tall	610 x 273mm

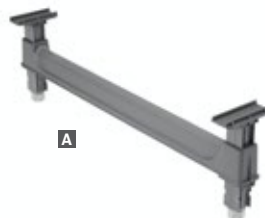

RECOMMENDED FOR
BASICS PLUS UNITS
1375MM AND WIDER



Camshelving® Elements Xtra Mobile Units

new

Each mobile vented starter unit includes 2 mobile post kits, shelves and 4 premium swivel casters with total locking brake. Unit height 1784mm as standard.

Camshelving® Elements Xtra Mobile Units 4 tier 1784mm high with vented shelves as standard.

WIDTH	DEPTH 610MM
915mm	EXMU243670V4480
1070mm	EXMU244270V4480
1220mm	EXMU244870V4480
1375mm	EXMU245470V4480



Camshelving® Premium

Why it's The Best!



1

Easy & Quick To Clean

- Smooth wipe clean polypropylene surface.
- Weldless construction so liquids and dirt cannot get inside crevices.
- Each Camshelving® component is dishwasher safe.
- Easy cleaning makes HACCP compliance simpler.
- Embedded CamGuard™ silver-ion technology continuously works to suppress the growth of mould, fungus & bacteria.



2

Easy To Adjust & Configure

- Build any configuration and fit any size area.
- Available in 5 Heights, 4 Depths and 12 Widths.
- Shelf heights adjustable in 100mm increments without disassembling the unit.
- No bolts, no nuts! Easy 1-Step slide together construction.
- Available with Level Footing, Wheels and Solid or Vented Shelves.

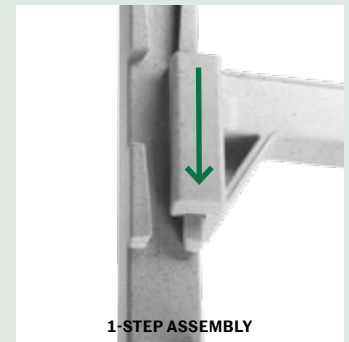

3

Strong, Durable & Stable

- 150 to 200kg load per shelf depending on the length of the traverse.
- 'Strong as Steel' weight-bearing upright Posts and horizontal Traverses.
- Unique engineering of the Post Connectors (top and bottom) provide exceptional cross stabilisation.
- Built-in straight lines, two shelving units can share an upright Post with no loss in weight-bearing capacity.



4

Rust Free

- Polypropylene surface won't rust even when washed or placed in wet or humid environments.
- Not even saltwater or sea air will corrode Camshelving®.
- Ideal for walk-in refrigerators and freezers as cold as -38°C or wet environments.
- Lifetime limited warranty against rust and corrosion for Traverses and Posts.
- Rust-free environment is vital for sanitary, HACCP compliant operation.

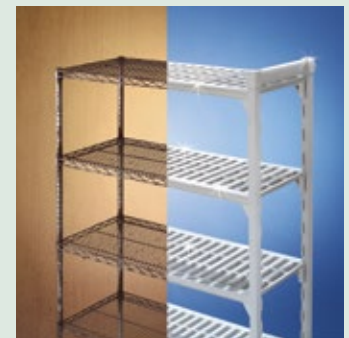

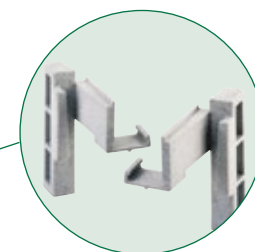
STARTER UNIT**ADD-ON UNIT****CORNER UNIT****CORNER CONNECTORS**

EACH PREMIUM STARTER UNIT INCLUDES 2 POST KITS AND 4 SHELF KITS

EACH PREMIUM ADD-ON UNIT INCLUDES 1 POST KIT AND 4 SHELF KITS

CORNER CONNECTORS CAN BE USED TO BUILD CORNER AND U-SHAPE UNITS.

Corner Connectors

MSCC 4 sets required per 4 tier unit

Camshelving® Premium Starter Units 4-Tier 1800mm high with vented shelves as standard.

WIDTH	DEPTH 400MM	DEPTH 500MM	DEPTH 600MM
680mm	MSU44618PKG	MSU45618PKG	MSU46618PKG
780mm	MSU44718PKG	MSU45718PKG	MSU46718PKG
880mm	MSU44818PKG	MSU45818PKG	MSU46818PKG
980mm	MSU44918PKG	MSU45918PKG	MSU46918PKG
1080mm	MSU441018PKG	MSU451018PKG	MSU461018PKG
1180mm	MSU441118PKG	MSU451118PKG	MSU461118PKG
1280mm	MSU441218PKG	MSU451218PKG	MSU461218PKG
1380mm	MSU441318PKG	MSU451318PKG	MSU461318PKG
1480mm	MSU441418PKG	MSU451418PKG	MSU461418PKG
1580mm	MSU441518PKG	MSU451518PKG	MSU461518PKG
1680mm	MSU441618PKG	MSU451618PKG	MSU461618PKG
1780mm	MSU441718PKG	MSU451718PKG	MSU461718PKG

Camshelving® Premium Add-on Units 4-Tier 1800mm high with vented shelves as standard.

WIDTH	DEPTH 400MM	DEPTH 500MM	DEPTH 600MM
635mm	MSA44618PKG	MSA45618PKG	MSA46618PKG
735mm	MSA44718PKG	MSA45718PKG	MSA46718PKG
835mm	MSA44818PKG	MSA45818PKG	MSA46818PKG
935mm	MSA44918PKG	MSA45918PKG	MSA46918PKG
1035mm	MSA441018PKG	MSA451018PKG	MSA461018PKG
1135mm	MSA441118PKG	MSA451118PKG	MSA461118PKG
1235mm	MSA441218PKG	MSA451218PKG	MSA461218PKG
1335mm	MSA441318PKG	MSA451318PKG	MSA461318PKG
1435mm	MSA441418PKG	MSA451418PKG	MSA461418PKG
1535mm	MSA441518PKG	MSA451518PKG	MSA461518PKG
1635mm	MSA441618PKG	MSA451618PKG	MSA461618PKG
1735mm	MSA441718PKG	MSA451718PKG	MSA461718PKG

Camshelving® Premium Shelf Kits

Each shelf kit includes 2 traverses and several vented shelf plates too build a single shelf.



Camshelving® Premium Shelf Kits Made of smooth polypropylene. Wipes clean. Rust proof.

WIDTH	DEPTH 400MM	DEPTH 500MM	DEPTH 600MM
600mm	MS4060VK	MS5060VK	MS6060VK
700mm	MS4070VK	MS5070VK	MS6070VK
800mm	MS4080VK	MS5080VK	MS6080VK
900mm	MS4090VK	MS5090VK	MS6090VK
1000mm	MS40100VK	MS50100VK	MS60100VK
1100mm	MS40110VK	MS50110VK	MS60110VK
1200mm	MS40120VK	MS50120VK	MS60120VK
1300mm	MS40130VK	MS50130VK	MS60130VK
1400mm	MS40140VK	MS50140VK	MS60140VK
1500mm	MS40150VK	MS50150VK	MS60150VK
1600mm	MS40160VK	MS50160VK	MS60160VK
1700mm	MS40170VK	MS50170VK	MS60170VK

Camshelving® Premium Mobile Units

Each mobile vented starter unit includes 2 mobile post kits, 4 shelf kits and 4 swivel castors with brakes. Unit height 1800mm as standard.



Cambro Premium Mobile Units 4-Tier 1800mm high with vented shelves as standard.

WIDTH	DEPTH 400MM	DEPTH 500MM	DEPTH 600MM
680mm	MSUR44617PKG	MSUR45617PKG	MSUR46617PKG
780mm	MSUR44717PKG	MSUR45717PKG	MSUR46717PKG
880mm	MSUR44817PKG	MSUR45817PKG	MSUR46817PKG
980mm	MSUR44917PKG	MSUR45917PKG	MSUR46917PKG
1080mm	MSUR441017PKG	MSUR451017PKG	MSUR461017PKG
1180mm	MSUR441117PKG	MSUR451117PKG	MSUR461117PKG
1280mm	MSUR441217PKG	MSUR451217PKG	MSUR461217PKG
1380mm	MSUR441317PKG	MSUR451317PKG	MSUR461317PKG
1480mm	MSUR441417PKG	MSUR451417PKG	MSUR461417PKG
1580mm	MSUR441517PKG	MSUR451517PKG	MSUR461517PKG
1680mm	MSUR441617PKG	MSUR451617PKG	MSUR461617PKG
1780mm	MSUR441717PKG	MSUR451717PKG	MSUR461717PKG

Dividers Bars & Shelves



- Angled divider bars hold pans and boxes at an angle for more ergonomic reach.
- Fits securely and adjusts easily.
- Shelf dividers prevent costly spills and stabilise stacked or narrow items.
- Slotted sides allow for hygienic air circulation for perishables.

Drying Racks

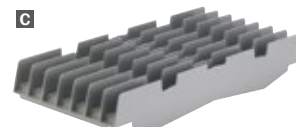

- Easy to install drying racks sit on shelving traverses.
- Sanitary Drying and efficient storage solution.
- Fits on 600mm deep Cambro Premium shelving and 610mm deep Cambro Elements Shelving.

Divider Bars & Shelves

CODE	DESCRIPTION	FITS
A CSDBA	Angled Divider Bar	600mm Deep Shelves
B CSSD248	Shelf Divider	600mm Deep Shelves

Drying Racks

CODE	DESCRIPTION	W X D X H
C CSDR7	Vertical Drying Rack	240 x 594 x 96mm
D CSDR8	Angled Drying Rack	263 x 592 x 160mm

Dunnage Racks

- Dunnage racks for storage off the floor, avoiding contaminants.
- 1-piece polyethylene construction.
- Loads of 680 to 1360kg depending on size.
- Ideal for walk-in coolers and freezers or dry inventory.
- 300mm above the floor, compliant with HACCP which calls for 150mm.
- Connectors lock racks together for greater stability.
- Easy to clean.



Wall Shelves



- Solid polypropylene high strength shelves with brackets.
- Do not rust.
- Easy to keep clean.

Dunnage Racks Elevated off the floor storage racks.

DRS300	760 x 530 x H310mm
DRS360	910 x 530 x H310mm
DRS480	1220 x 530 x H310mm
DRS600	1525 x 530 x H310mm



Wall Shelves

CSWS1436SK	910 x 360 x 340mm
CSWS1448SK	1220 x 360 x 340mm

Camshelving® Elevation Series Wall Shelving

new

SHELVING & TROLLEYS

The Camshelving Elevation Series is the ultimate solution for creating hygienic, efficient, and adaptable storage spaces in commercial kitchens.

The system will never rust, corrode, peel or dent, as long as you're in business. Choose from standard kits or customise your space with individual components and accessories to fit your needs.



Sink Station Wall Shelving

Starter Kit Includes:

- 1 x 1016mm Aluminium Wall Track.
- 2 x 762mm Wall Uprights.
- 1 x 460 x 915mm Vented Shelf Kit.
- 1 x 460 x 915mm Hanging Pegboard.
- Stainless Steel Accessories.
- 1 x Large Wire Basket.
- 1 x Small Shelf Lid Holder.
- 1 x Cylinder & Hooks.
- 8 x Peg Hooks.

Add-On Kit contains all of the above, minus 1 x wall upright.

Sink Station Wall Shelving

CODE	DESCRIPTION	W X D X H
EWS36SINK	Sink Station Starter Kit	915 x 460 x 770mm
EWSA36SINK	Sink Station Add-On Kit	915 x 460 x 770mm



Prep Station Wall Shelving

Starter Kit Includes:

- 1 x 1016mm Aluminium Wall Track.
- 2 x 762mm Wall Uprights.
- 1 x 460 x 915mm Vented Shelf Kit.
- 1 x 460 x 915mm Hanging Pegboard.
- Stainless Steel Accessories.
- 2 x Large Wire Basket.
- 1 x Small Shelf Lid Holder.
- 1 x Cylinder & Hooks.
- 8 x Peg Hooks.

Add-On Kit contains all of the above, minus 1 x wall upright.

Prep Station Wall Shelving

CODE	DESCRIPTION	W X D X H
EWS36PREP	Prep Station Starter Kit	915 x 460 x 770mm
EWSA36PREP	Prep Station Add-On Kit	915 x 460 x 770mm



Camshelving® Elevation Series Wall Shelving

new

Task Station Wall Shelving



Starter Kit Includes:

- 1 x 1016mm Aluminium Wall Track.
- 2 x 762mm Wall Uprights.
- 1 x 460 x 915mm Vented Shelf Kit.
- 1 x 460 x 915mm Hanging Pegboard.

Add-On Kit contains all of the above, minus 1 x wall upright.

Task Station Wall Shelving

CODE	DESCRIPTION	W X D X H
EWS36TASK	Task Station Starter Kit	915 x 460 x 770mm
EWSA36TASK	Task Station Add-On Kit	915 x 460 x 770mm

ADD-ON KIT

Accessories new

Pegboards

- ¼" thick ABS plastic with ¼" diameter moulded-in peg holes.
- Attach securely onto wall upright hooks (hanging) or mount directly (wall-mount) onto the wall between uprights.
- Maximum weight bearing per pegboard is 100lbs.

Pegboards

CODE	DESCRIPTION	W X D
EWSPB36	Hanging Pegboard	915 x 460mm
EWSFP1836	Wall-Mount Pegboard	915 x 460mm



WALL-MOUNTED PEGBOARD



HANGING PEGBOARD

Pegboards Accessories

- 304 stainless steel.
- Each accessory includes mounting screws.
- Unique double locking tab design.
- Maximum weight bearing per accessory is 15lbs.

Pegboard Accessories

CODE	DESCRIPTION	CODE	DESCRIPTION
EWSACC1	Bottle Holder	EWSACC6	Large Wire Basket
EWSACC2	Large Utensil Holder	EWSACC7	1/3 Drain Pan With Holder
EWSACC3	Small Utensil Holder	EWSACC8	6" Straight Pegs (8 pack)
EWSACC4	Cylinder With Holder	EWSACC9	Small Shelf / Lid Holder
EWSACC5	Bin With Holder		



SHOWS UTENSIL HOLDER, DRAIN PAN, PEGS & BIN WITH HOLDER

TO VIEW ALL ACCESSORIES
PLEASE VISIT FEM.CO.UK

Camshelving® Universal Storage Rack

SHELVING & TROLLEYS



SHELVING UNIT
SOLD SEPARATELY

A unique way to create vertical storage space. Easily create individual storage sections with rail panels to hold pans, trays, boxes and much more transforming YOUR storage!

- Easily create individual storage sections with rail panels.
- Ideal for kitchens, coolers, freezers, dry storage and more.
- Holds food pans, boxes, sheet pans, trays, and even pizza dough boxes.
- Dishwasher-safe and rust-free.

For Basics Plus® Shelving

CODE	DESCRIPTION	FITS SHELVING
CBUNVR24	Starter Kit	610mm Deep
CBUNVRA24	Add-on kit	610mm Deep

For Premium® Shelving

CODE	DESCRIPTION	FITS SHELVING
MPUNVR600	Starter Kit	600mm Deep
MPUNVRA600	Add-on Kit	600mm Deep

ALSO AVAILABLE FOR 540M DEEP SHELVING

Kits Contents

Storage Rack Starter Kit

- 2 x Rail Panels.
- 8 x Bracket Sets.
- 8 x Traverse Sets.
- 8 x Thumbscrews.

Storage Rack Add-On Kit

- 1 x Rail Panel.
- 4 x Bracket Sets.
- 4 x Traverse Sets.
- 4 x Thumbscrews.

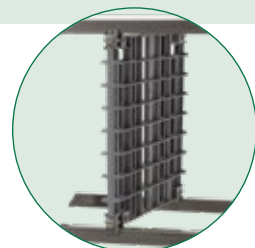

Gastronorm Food Pan Trolley

A space-saving, heavy-duty GN pan trolley built for efficient food storage, transport and long-term durability in demanding kitchens.

- Compact, end-load GN pan trolley for storing, holding and transporting bulk food while maximising workspace.
- Ultra-strong composite construction with a smooth, easy-clean surface and lifetime warranty against rust and corrosion.
- Rails accept hot pans up to 200°C with 76mm spacing, moulded lip-load rails, and pan stops for secure transport.
- Top frame supports a GN 1/1 pan or converts half-size units into a light-duty workstation.
- Four heavy-duty 127mm swivel casters with total-lock brakes and non-marking wheels.
- Knockdown shipment with minimal assembly; modular, replaceable components.
- Vinyl and insulated covers for GN Trolley sizes protect contents held/staged in kitchens, coolers, or freezers.



Gastronorm Food Pan Trolley

CODE	PAN SIZE	RAILS	CAPACITY	W X D X H
A UGNPR11F18	1/1	18	340kg	438 x 730 x 1707mm
UGNPR11H9	1/1	9	170kg	438 x 730 x 1016mm
UGNPR21F36	2/1	18	340kg	645 x 835 x 1707mm
B UGNPR21H18	2/1	9	170kg	645 x 835 x 1016mm

GN Trolley Covers Vinyl is Clear (CLR), & Insulated is Black (110).

COVER	DESCRIPTION	FITS
GBVC11F	Vinyl	1/1 GN Trolley
GBVC21F	Vinyl	1/2 GN Trolley
GBIC11F	Insulated	1/1 GN Trolley
GBIC21F	Insulated	1/2 GN Trolley

Baking Tray Trolley

Multi-purpose end-load trolley for 60 x 40 sheet or food pans. Slim, compact design maximises workspace and storage.

- Ultra-strong, non-metal composite construction with smooth, easy-to-clean surface; lifetime warranty against rust and corrosion.
- Rails hold hot pans up to 200 °C with wide 77mm spacing and moulded-in pan stops; the top frame supports a single pan for covering or light-duty workstation use.
- Capacity: Full-size 18 pans / 340 kg, Half-size 9 pans / 170 kg; 18 kg per rail set.
- Four 12.7 cm swivel casters with total-lock brakes, non-marking, rust- and corrosion-free.
- Easy to clean; ships knockdown with minimal assembly; components replaceable for long service life.
- Vinyl and insulated covers available for full-size 6040
- Baking Trolley Only, protecting contents held/staged in kitchens, coolers, or freezers.



Baking Tray Trolley

CODE	PAN SIZE	RAILS	CAPACITY	W X D X H
C UPR6040F18	600 x 400mm	18	340kg	516 x 783 x 1708mm
D UPR6040H9	600 x 400mm	9	170kg	516 x 783 x 1014mm

Baking Trolley Covers Vinyl is Clear (CLR), & Insulated is Black (110).

COVER	DESCRIPTION	FITS
UPR6040CVR	Vinyl	Full Size 6040 Trolley
GBIC6040	Insulated	Full Size 6040 Trolley

Gastronorm Transport Trolley



- Sturdy and robust self-assembly trolley.
- Transport trolley suitable for gastronorm pans.
- Castors for easy transportation.
- 75mm between rails.

Gastronorm Transport Trolleys

CODE	RAILS	SHELF SIZE	W X D X H
A 80540	7	GN 1/1	455 x 635 x 900mm
B 80430	17	GN 1/1	455 x 635 x 1710mm
80440	17	GN 2/1	660 x 755 x 1710mm

Gastronorm Self Assembly Trolley



- Sturdy and robust self-assembly trolley.
- Castors for easy manoeuvrability.
- 17 rails suitable for transporting gastronorm pans.
- 75mm between rails.

Gastronorm Self Assembly Trolleys 17 Rails

CODE	RAILS	SHELF SIZE	W X D X H
80470	17	GN 1/1	455 x 635 x 1710mm
80480	17	GN 2/1	660 x 755 x 1710mm

Self-Service Tray Trolley



- 12 rail self-service trolley.
- Suitable for transporting trays between 365mm to 420mm.
- 140mm between rails.
- Castors for easy manoeuvrability.
- Available with optional aluminium + composite side panels.
- Fully welded construction.

Self-service trolley 12 rails

CODE	DESCRIPTION	RAILS	W X D X H
80950	Open Sides	12	550 x 660 x 1710mm
80951	With Side Panels	12	550 x 660 x 1710mm

Dishwasher Rack Trolley



- Dishwasher rack trolley.
- Suitable for transporting standard 500 x 500mm dishwasher racks.
- Castors for easy manoeuvrability.
- Single and double trolleys available.
- Fully welded construction.

Dishwasher Rack Trolley Suitable for transporting standard 500 x 500mm dishwasher racks.

CODE	RAILS	SHELF SIZE	W X D X H
80750	5	500 x 500	640 x 633 x 1160mm
80760	9	500 x 500	640 x 633 x 1710mm
80770	18	500 x 500 (double)	1185 x 633 x 1710mm

Plate Trolley



PERFECT FOR
PLATE STORAGE FOR
BANQUETING SERVICE
& BACK-OF-HOUSE
AREAS

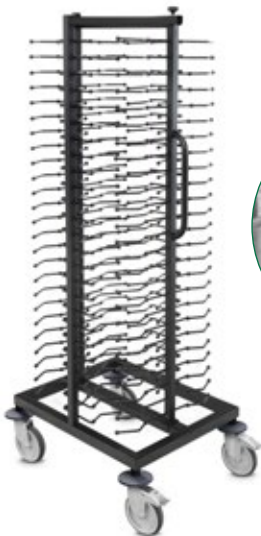

NEW PLATE
TROLLEY
COVER NOW
AVAILABLE

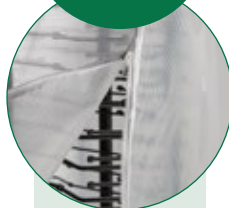

MADE OF
REINFORCED
HIGH-DENSITY
POLYETHYLENE

- Capacity for 100 plates, different sizes of plate can be combined thanks to the adjustable system.
- Holds max plate Ø345mm with height between each level 58mm.
- Carbon steel material with anti-corrosion coating.
- Strong welded handle for easy transportation.
- Revolving Ø125mm castors, 2 with brakes.
- 80793 has 4 zippers for easy access from any point, with a handle opening for easy transportation.

Plate Trolley

CODE	DESCRIPTION	CAPACITY	W X D X H
80790	Plate Trolley	100 dishes	580 x 710 x 1775mm
80793	Polyethylene Cover	-	620 x 710 x 1520mm

Stainless Steel Serving Trolley new



A



MAX LOAD PER SHELF 50KG
TOTAL MAXIMUM LOAD 150KG

- Fully welded construction.
- 1.5mm thick stainless steel tubular frame.
- Moulded shelves welded onto frame.
- Soundproof revolving Ø125mm castors, 2 with brakes.
- Maximum load per shelf 80kg, total maximum load 250kg.
- 80282 model has panels to isolate stored items, reducing contamination levels significantly - Ideal for delivering food and medical supplies safely.

Stainless Steel Serving Trolley

CODE	DESCRIPTION	SHELF SIZE	W X D X H
80240	2 Shelf Silver	800 x 500mm	880 x 580 x 1015mm
80270	3 Shelf Silver	800 x 500mm	880 x 580 x 1015mm
A 80282	3 Shelf Silver	800 x 500mm	980 x 580 x 1015mm
B 80980	3 Shelf Black	825 x 500mm	905 x 590 x 945mm

Foldable Service Trolley



new

- Collapse in half at ease and secure with safety latch.
- 4 revolving castors, 2 with brakes.
- Total maximum load 150kg, max. load per shelf 50kg.
- Structure in stainless steel and shelves in polypropylene.

Foldable Service Trolley

CODE	SHELF SIZE	W X D X H
642100	825 x 500	930 x 510 x 930mm

Dish Trolley



D



new

- Robust, resistant stainless steel structure.
- Includes 2 dividers which can be adjusted.
- Base tilted inwards to prevent plates falling.
- 4 x Ø125mm wheels with bumpers, 2 wheel brakes included.

Dish Trolley

CODE	SHELF SIZE	W X D X H
C 80791	150 Plates Up To Ø320mm	1050 x 500 x 850mm
D 80792	300 Plates Up To Ø320mm	1050 x 780 x 850mm

KD Carts



- Versatile, strong and durable, these carts ship 'knocked down' to maximise shipping costs.
- 3 generously polypropylene shelves.
- Durable, stain-resistant surface is easy to clean.
- Four powder coated steel swivel castors provide quiet transport and steady manoeuvring.
- Saturday aluminium uprights and marine rail to keep contents on place.

KD Carts Available in black (110) or Speckled Grey (480).

CODE	DESCRIPTION	CAPACITY	W x D x H
A BC340KD	Utility Cart	180kg	1015 x 540 x 950mm
B BC331KD	Service Cart	136kg	835 x 413 x 965mm

KD Cart Accessories

CODE	DESCRIPTION
BC331KDTC	Attachable 30L Trash Container
BC331KDSH	Attachable 9.5L Silverware Holder
BC340KDP	Single Shelf Panel Kit for BC340KD

Tray & Silver Cart



Tray & Silver Cart Use to neatly organize trays and accessories for self-service. Protective vinyl cover and eight clear Camwear® food pans included. Max tray size 360 x 460mm.

CODE	CAPACITY	W x D x H
TC1418	227kg	820 x 540 x 1160mm

Service Cart Pro



- Modern look ideal for front and back of house applications.
- Ergonomic moulded-in handles offer easy manoeuvring.
- Handles are recessed to reduce footprint and improve storage.
- Shelves feature raised ridges to protect the surface against heat.
- Constructed from rotomoulded plastic that doesn't dent or chip.
- Total weight capacity: 272 kg, 90,7 kg per shelf.
- Optional bins provide extra storage.
- Smooth, easy to clean material.

Service Cart Pro Durable, one-piece polyethylene construction.

CODE	DESCRIPTION	L X W X H
SC337S	Castors: 4 swivel with brake	1054 x 603 x 904mm

Colours: Available in black, charcoal grey and dark brown.

Service Cart Pro Accessories

CODE	DESCRIPTION
QCSB	Small Quick Connect Bin
QCTB	Large Quick Connect Bin

CUBIC® Trolleys



CUBIC® Trolleys Wood and aluminium construction.

CODE	W x D x H
80219	550 x 700 x 800mm
80220	1050 x 550 x 850mm

Adjustable Dish Caddies



Standard S-Series Adjustable Dish Caddy Store and transport valuable dinnerware in this durable dish caddy with superior strength and maximum storage capacity. Easy-to-adjust column towers neatly stack and protect either a one-size dish or a combination of shapes, sizes and types of dinnerware. Fits 45-60 plates. Add the colour code required to item code. Vinyl cover included.

CODE	PLATES SIZE	COLUMNS	W x D x H
ADCS	Ø117-330mm	6	730 x 960 x 810mm



401 480 110 131

Compact Adjustable Dish Caddy S-Series Offers a smaller footprint without compromising performance or storage capacity. The Patented CamLever Towers adjust from the top, making it easy to modify the towers for new dish sizes. One-piece, highly durable polyethylene construction. Fits 45-70 plates. Available in speckled grey only (480). Vinyl cover included.

CODE	PLATES SIZE	COLUMNS	W x D x H
ADCSC	Ø229-305mm	6	686 x 686 x 807mm

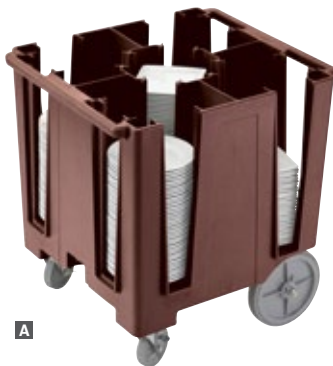

A

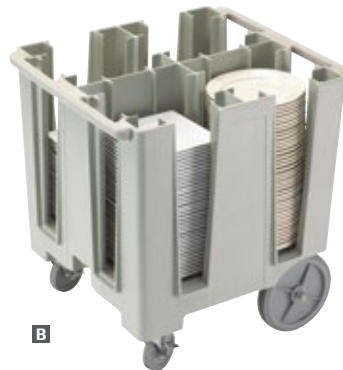

B



C



VINYL COVER INCLUDED FOR SANITARY STORAGE

Dish Caddies Rounded corners inside and out protect china, walls and furniture. Features two 127mm swivel castors with brakes and two 254mm easy wheels. Each column holds between 45-60 plates. Add the colour code required to item code. Slate Blue (401*) available for the DC1225 only. Vinyl cover included.

CODE	PLATE SIZE	COLUMNS	W x D x H
A DCS950	Ø213-241mm / 184-205mm (Square)	4 to 5	690 x 780 x 810mm
B DCS1125	Ø224-286mm / 213-241mm (Square)	4	690 x 780 x 810mm
C DC1225	Ø289 to 311mm	4	830 x 700 x 815mm

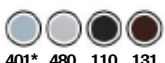

401* 480 110 131



Featured Brands

CAMBRO
TRUSTED DURABILITY

pujadas
A VOLLRATH COMPANY

san jamar
smart. safe. sanitary.

VOLLRATH

Food Storage

Every kitchen needs effective food storage to operate at its best. From organising dry goods to storing pre-prepared ingredients for busy services, proper storage is essential. Great solutions are easy to clean, support HACCP compliance by reducing handling and contamination, and make your kitchen easier to run. Our durable, reliable products are built from high-quality materials to withstand heavy commercial use and provide long-lasting, professional performance.



GN First Stainless Steel GN Pans	160
GN Pro Stainless Steel GN Pans	161
GN Pro Gastronorm Accessories & Polinorm Lids	162
Gastronorm Size Chart	163
Bain Maries & Insets	163
High Heat H-PAN GN Pans	164
Camwear Polycarbonate GN Pans	166
Camwear Gastronorm Covers	167
Polypropylene Gastronorm Pans	168
SafeTrak GN Food Pans	169
ColdFest Pans	170
Polycarbonate Camwear Food Storage Boxes	170
Polypropylene CamRound FreshPro Containers	171
Polypropylene CamSquare FreshPro Containers	172
Classic CamSquare Polycarbonate Containers	173
Measuring Jugs	174
Dough Boxes	175
Polycarbonate Scoops	175
Ingredient Bins	175
Ice Management Scoops & Tools	176
SlidingLid Ice Caddies & Drain Grate	177

GN FIRST

new

An affordable way to take your kitchen to the next level...

- Sturdy 18/0 - AISI 201 stainless steel construction.
- Flattened edges and corners prevent bending and provide a wider grasp when removing.
- Overhanging rim makes these pans perfect for buffet and prep stations. Ideal for cooking in ovens, transport (buffets, catering or delivery), storage and presentation in hot and cold buffets.



201
18-0
STAINLESS STEEL
CONSTRUCTION

GN FIRST 18/0 Solid Stainless Steel Gastronorm Pans Standard GN sizes. Available in various sizes and depths. GN size chart page 163.

1/1

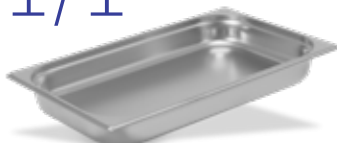

110207	D20mm
110407	D40mm
110557	D55mm
110657	D65mm
111007	D100mm
111507	D150mm
112007	D200mm

2/3



230207	D20mm
230407	D40mm
230657	D55mm
231657	D65mm
231007	D100mm
231507	D150mm
232007	D200mm

1/2



120207	D20mm
120407	D40mm
120557	D55mm
120657	D65mm
121007	D100mm
121507	D150mm
122007	D200mm

2/4

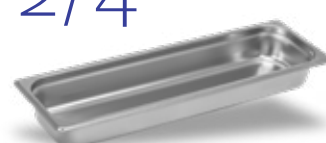

240407	D40mm
240657	D65mm
241007	D100mm
241507	D150mm

1/3

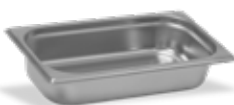

130207	D20mm
130407	D40mm
130657	D65mm
131007	D100mm
131507	D150mm
132007	D200mm

1/4



140207	D20mm
140657	D65mm
141007	D100mm
141507	D150mm
142007	D200mm

1/6



160657	D65mm
161007	D100mm
161507	D150mm
162007	D200mm

1/9



190657	D65mm
191007	D100mm

PERFORATED
GN FIRST PANS
ALSO AVAILABLE
VISIT FEM.CO.UK

Gastronorm Accessories for GN FIRST

A GN FIRST Solid Covers

Available in all standard GN sizes.

110007	1/1
230007	2/3
120007	1/2
130007	1/3
140007	1/4
160007	1/6
190007	1/9

B GN FIRST Hermetic Covers

Available in all standard GN sizes.

110007H	1/1
120007H	1/2
130007H	1/3
140007H	1/4

C Adaptor Bars

Available in the below sizes.

111111	1/1 (20")
122222	1/2 (12")



CONVENIENT HANDLE FOR EASY
POSITIONING AND OPENING

VERSATILE BARS USED TO
ARRANGE YOUR BUFFET
DISPLAY AND UTILISE SPACE
MORE EFFICIENTLY

FOOD STORAGE

GN PRO

304

18-10
STAINLESS STEEL
CONSTRUCTION

- Suitable for a wide range of temperatures from oven cooking to chilling. Angled ramp - pull and lift pans with ease.
- Reinforced corners for added strength.
- Sturdy 22-gauge, 304-euro norm 18-10 stainless steel construction.
- Flattened edges - prevent bending and provide wider grasp when removing.



**FULL RANGE OF
ACCESSORIES AVAILABLE
SEE GN SIZE CHART PAGE 163**



GN PRO 18/10 Solid Stainless Steel Gastronorm Pans Standard GN sizes. Available in various sizes and depths.

2/1



210201	D20mm
210401	D40mm
210651	D65mm
211001	D100mm
211501	D150mm
212001	D200mm

1/1



110201	D20mm
110401	D40mm
110551	D55mm
110651	D65mm
111001	D100mm
111501	D150mm
112001	D200mm

2/3



230201	D20mm
230401	D40mm
230651	D65mm
231001	D100mm
231501	D150mm
232001	D200mm

1/2



120201	D20mm
120401	D40mm
120651	D65mm
121001	D100mm
121501	D150mm
122001	D200mm

2/4



240401	D40mm
240651	D65mm
241001	D100mm
241501	D150mm

1/3



130201	D20mm
130401	D40mm
130651	D65mm
131001	D100mm
131501	D150mm
132001	D200mm

1/4



140201	D20mm
140651	D65mm
141001	D100mm
141501	D150mm
142001	D200mm

1/6



160651	D65mm
161001	D100mm
161501	D150mm
162001	D200mm

1/9



190651	D65mm
191001	D100mm

GN PRO 18/10 Perforated Stainless Steel Gastronorm Pans Standard GN sizes. Available in various sizes and depths. GN size chart page 153.

2/1

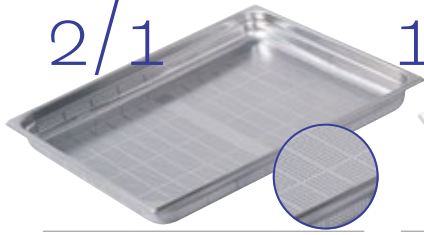

1/1



1/2



1/3



210202 D40mm

210402 D55mm

210652 D65mm

211002 D100mm

211502 D150mm

212002 D200mm

110202 D20mm

110402 D40mm

110552 D55mm

110652 D65mm

111002 D100mm

111502 D150mm

112002 D200mm

120652 D65mm

121002 D100mm

121502 D150mm

122002 D200mm

130202 D20mm

130402 D40mm

130652 D65mm

131002 D100mm

131502 D150mm

132002 D200mm

Gastronorm Accessories for GN Pro



A



C



E



B

D



F

**WATERTIGHT LID WITH REINFORCED RIM
TEMP RANGE -40°C TO 110°C**

A GN PRO Solid Covers Available in all standard Gastronorm sizes.

110000 1/1

230000 2/3

120000 1/2

130000 1/3

140000 1/4

160000 1/6

190000 1/9

C GN PRO Drain Shelves Available in all standard Gastronorm sizes.

115000 1/1

125000 1/2

135000 1/3

145000 1/4

D Adaptor Bar

122222 Short 12"

111111 Long 20"

E Wire Grate Stainless steel. For use with Gastronorm pans.

74100 1/1 435 x 250mm

74200 1/2 233 x 170mm

F Polinorm® Lids Available in all standard Gastronorm sizes.

1100P1 1/1 Clear

1200P1 1/2 Clear

1300P1 1/3 Clear

1400P1 1/4 Clear

1600P1 1/6 Clear

1900P1 1/9 Clear

1100P2 1/1 Red

1200P2 1/2 Red

1300P2 1/3 Red

1400P2 1/4 Red

1600P2 1/6 Red

1900P2 1/9 Red

1100P6 1/1 Purple

1200P6 1/2 Purple

1300P6 1/3 Purple

1600P6 1/6 Purple

B GN PRO Gasketed Transport Lids Available in all standard Gastronorm sizes.

110004 1/1

120004 1/2

130004 1/3

140004 1/4

160004 1/6

STORAGE POLINORM LIDS ARE SUITABLE FOR STAINLESS STEEL, POLYCARBONATE, POLYPROPYLENE AND BPA-FREE GN CONTAINERS.

***NOT SUITABLE FOR USE WITH GN FIRST CONTAINERS.**

**FULL LID RANGE
VISIT LID.CO.UK**



Gastronorm Size Chart

Gastronorm Pan Sizes Available standard or perforated in varying depths. Sizes in mm.



FOOD STORAGE

Bain Maries & Insets



Stainless Steel Bain Maries Satin-finished 18-8 stainless steel. Bain Maries nest together for compact storage. 152mm depth under shoulder. Slotted and hinged cover options to reduce heat loss.

78164	3.9L	Ø189 x D208mm	Fits opening Ø165mm
78184	6.9L	Ø240 x D208mm	Fits opening Ø216mm
78204	10.4L	Ø295 x D208mm	Fits opening Ø267mm

Stainless Steel Insets Satin-finished 18-8 stainless steel. Sanitary open bead on edge. Ideal for salad bar, dressing and condiment service. Recessed stainless steel covers for sanitary storage.

78710	1.2L	Ø105 x D146mm	Fits opening Ø108mm
78720	1.9L	Ø124 x D171mm	Fits opening Ø127mm
78740	4L	Ø165 x D194mm	Fits opening Ø168mm
78760	5.7L	Ø184 x D219mm	Fits opening Ø187mm



Slotted Cover

78160	Ø192mm
78180	Ø243mm
78200	Ø291mm



Hinged Cover

47488	Ø247mm
47490	Ø292mm



DESIGNED SPECIFICALLY TO FIT IN STANDARD UK BAIN MARIES

8 Pint Pot Stainless steel pot. Made for standard UK Bains Maries. Cover included.

46825	8 pints (4.5L)	Ø180 x D215mm
-------	----------------	---------------

High Heat H-PAN™ Gastronorm Pans

High Heat H-PAN™ and Covers

- Withstand temperatures -40°C to 190°C.
- Safe for use in microwaves, steam tables and ovens.
- Use one pan from prep, to cooler, to oven, to hot holding applications without having to transfer from one pan to another.
- Commercial dishwasher safe.
- Great for flash freezing, cooking and reheating.
- Non-stick smooth interior surface increases yields and promotes easy cleaning.
- Pans stack neatly without wedging or sticking.



High Heat Colander Pans
COOK, DRAIN, HOLD AND STORE
ALL-IN-ONE PAN. COLANDERS
DRAIN LIQUIDS & GREASE AWAY
FROM HOT FOODS, IMPROVING
FOOD QUALITY.

High Heat Colander Pans

13CLRHP	1/1 D76mm
23CLRHP	1/2 D76mm
33CLRHP	1/3 D76mm
63CLRHP	1/6 D76mm
15CLRHP	1/1 D127mm
25CLRHP	1/2 D127mm
35CLRHP	1/3 D127mm
65CLRHP	1/6 D127mm



Drain Shelves
LIFT CONTENTS OUT OF LIQUIDS
AND PROMOTE DRAINAGE TO
ENHANCE FOOD QUALITY AND
FRESHNESS. SHOWN IN 1/3 GN PAN.

Drain Shelves

10HPD	1/1
20HPD	1/2
30HPD	1/3
40HPD	1/4
60HPD	1/6
80HPD	1/8
90HPD	1/9

High Heat H-PAN™ Gastronorm Pans

To order Amber add 150 to the item code and to order Black add 110 to the item code.

GN size chart page 163.

1/1	12HP	D65mm
	14HP	D100mm
	16HP	D150mm
1/2	22HP	D65mm
	24HP	D100mm
	26HP	D150mm
2/4	22LPHP	D65mm
	24LPHP	D100mm
1/3	32HP	D65mm
	34HP	D100mm
	36HP	D150mm
1/4	42HP	D65mm
	44HP	D100mm
	46HP	D150mm
1/6	62HP	D65mm
	64HP	D100mm
	66HP	D150mm
1/8	82HP	D65mm
	84HP	D100mm
	86HP	D150mm
1/9	92HP	D65mm
	94HP	D100mm
	96PHP	D150mm

High Heat Gastronorm Covers

FOR FULL RANGE OF
COVERS PLEASE VISIT
WWW.FEM.CO.UK



A Cover with Handle Deep moulded handle provides secure grip.

10HPCH	GN 1/1
20HPCH	GN 1/2
30HPCH	GN 1/3
40HPCH	GN 1/4
60HPCH	GN 1/6
80HPCH	GN 1/8

B Notched Cover with Handle Notched cover allows utensils to remain in pan and off of potentially contaminated surfaces.

10HPCHN	GN 1/1
20HPCHN	GN 1/2
30HPCHN	GN 1/3
40HPCHN	GN 1/4
60HPCHN	GN 1/6
80HPCHN	GN 1/8

C FlipLid® Lid to easily access contents food can be held without drying out, increasing yields.

20HPL	GN 1/2
30HPL	GN 1/3
60HPL	GN 1/6

D GripLid® Lid gasket 'grips' the side of the pan, reducing spills and points of cross-contamination.

10CWGL	GN 1/1
20CWGL	GN 1/2
30CWGL	GN 1/3
60CWGL	GN 1/6

High Heat Food Pan with Handles

- Fits all leading manufacturer's hot holding bins, including single-sided and pass-through models.
- High Heat Material withstands temperatures from -40°C to 190°C.
- Flat base to maximise contact with heating element.
- Reinforced textured handle with finger grip design for a secure grasp.
- Amber colour provides product visibility and easy identification.



NEW
PERFECT FOR PLANT-BASED PROTEINS AND VEGETARIAN ITEMS

High Heat Food Pan w/Handles Handles on both sides allow for easy and safe handling.

12HPH	1/1	D65mm
-------	-----	-------

High Heat 1/3 Food Pan with Handles Handle for easy and safe handling, for use with holding bins. Add 150 for amber, 110 for black, 473 for green and BLUE for blue.

32HP1H	Single Handle	GN 1/3 D65mm
32HP2H	Double Handle	GN 1/3 D65mm

Camwear® Low Temp Polycarbonate Gastronorm Pans

Camwear® Pans and Covers

- Store, transport and serve all in one pan.
- Virtually unbreakable Camwear® polycarbonate will not crack, bend or dent.
- Withstands temperatures from -40°C to 99°C.
- Precisely designed to Gastronorm GN specifications.
- Non-stick smooth interior surface increases yields and promotes easy cleaning.
- Stack neatly, without wedging or sticking.



PERSONALISATION AVAILABLE



GN Colander Pans

RINSE, DRAIN AND STORE ALL-IN-ONE PAN. COLANDERS SIMPLY LIFT OUT THE FOOD PAN FOR SAFE, QUICK AND EASY DISPOSAL OF LIQUIDS.

GN Colander Pans

13CLRCW	1/1 D76mm
23CLRCW	1/2 D76mm
33CLRCW	1/3 D76mm
63CLRCW	1/6 D76mm
15CLRCW	1/1 D127mm
25CLRCW	1/2 D127mm
35CLRCW	1/3 D127mm
65CLRCW	1/6 D127mm



Drain Shelves
LIFT CONTENTS OUT OF LIQUIDS AND PROMOTE DRAINAGE TO ENHANCE FOOD QUALITY AND FRESHNESS

Drain Shelves

10CWD	1/1
20CWD	1/2
30CWD	1/3
40CWD	1/4
60CWD	1/6
80CWD	1/8
90CWD	1/9

Camwear® Polycarbonate Gastronorm Pans

To order Clear add 135 to the item code and to order Black add 110 to the item code. 28CW and 82CW not available in black. GN size chart page 163.

1/1	12CW	D65mm
	14CW	D100mm
	16CW	D150mm
	18CW	D200mm
1/2	22CW	D65mm
	24CW	D100mm
	26CW	D150mm
	28CW	D200mm
2/4	22LPCW	D65mm
	24LPCW	D100mm
1/3	32CW	D65mm
	34CW	D100mm
	36CW	D150mm
	38CW	D200mm
1/4	42CW	D65mm
	44CW	D100mm
	46CW	D150mm
1/6	62CW	D65mm
	64CW	D100mm
	66CW	D150mm
1/8	82CW	D65mm
	84CW	D100mm
	86CW	D150mm
1/9	92CW	D65mm
	94CW	D100mm
	96PCW	D150mm

Camwear® Gastronorm Covers



Flat Cover Basic cover available in all pan sizes.

10CWC	GN 1/1
20CWC	GN 1/2
30CWC	GN 1/3
40CWC	GN 1/4
60CWC	GN 1/6
80CWC	GN 1/8
90CWC	GN 1/9



Cover with Handle Deep moulded handle provides secure grip.

10CWCH	GN 1/1
20CWCH	GN 1/2
30CWCH	GN 1/3
40CWCH	GN 1/4
60CWCH	GN 1/6
80CWCH	GN 1/8



Notched Cover with Handle Notched cover allows utensils to remain in pan and off of potentially contaminated surfaces.

10CWCHN	GN 1/1
20CWCHN	GN 1/2
30CWCHN	GN 1/3
40CWCHN	GN 1/4
60CWCHN	GN 1/6
80CWCHN	GN 1/8



Seal Cover Economical option for light storage in all pan sizes.

10PPCWSC	GN 1/1
20PPCWSC	GN 1/2
30PPCWSC	GN 1/3
40PPCWSC	GN 1/4
60PPCWSC	GN 1/6
80PPCWSC	GN 1/8
90PPCWSC	GN 1/9



Notched FlipLid® Flip up lid allows easy access to food and prevents contents from drying out. Notch to rest spoon with lid closed.

20CWLN	GN 1/2
30CWLN	GN 1/3
60CWLN	GN 1/6



GripLid® Lid gasket 'grips' the side of the pan, reducing spills and points of cross-contamination.

10CWGL	GN 1/1
20CWGL	GN 1/2
30CWGL	GN 1/3
60CWGL	GN 1/6

Translucent Polypropylene Gastronorm Pans

Polypropylene Pans and Covers

- Store, transport and serve all in one pan.
- Withstands temperatures from -40°C to 70°C.
- Precisely designed to Gastronorm GN specifications.
- Non-stick smooth interior surface increases yields and promotes easy cleaning.
- Translucent pans are not designed for steam table use.



Translucent Polypropylene Gastronorm Pans

To order translucent add 190 to the item code.
GN size chart page 163.

1/1	12PP	D65mm
	14PP	D100mm
	16PP	D150mm
	18PP	D200mm
1/2	22PP	D65mm
	24PP	D100mm
	26PP	D150mm
	28PP	D200mm
1/3	32PP	D65mm
	34PP	D100mm
	36PP	D150mm
1/4	42PP	D65mm
	44PP	D100mm
	46PP	D150mm
1/6	62PP	D65mm
	64PP	D100mm
	66PP	D150mm
1/9	92PP	D65mm
	94PP	D100mm

Cover with Handle

10PPCH	1/1 w/ handle
20PPCH	1/2 w/ handle
30PPCH	1/3 w/ handle
40PPCH	1/4 w/ handle
60PPCH	1/6 w/ handle
90PPC	1/9 Flat cover

Seal Covers

10PPCWSC	1/1 Seal cover
20PPCWSC	1/2 Seal cover
30PPCWSC	1/3 Seal cover
40PPCWSC	1/4 Seal cover
60PPCWSC	1/6 Seal cover
90PPCWSC	1/9 Seal cover

Red Polypropylene Gastronorm Pans

- Specifically designed for storing, transporting and serving raw meat products all in one pan.
- Non-stick smooth interior surface increases yield and promotes easy cleaning.
- Stacking saves valuable space when not in use.
- Withstands temperatures from -40°C to 70°C.



Red Polypropylene Gastronorm Pans

1/1	14PP467	D100mm	1/3	34PP467	D100mm
	16PP467	D150mm		36PP467	D150mm
	18PP467	D200mm		64PP467	D100mm
1/2	26PP467	D150mm	66PP467	D150mm	

Red Seal Cover Fits Red Polypropylene GN pans.

10PPCWSC467	GN 1/1
20PPCWSC467	GN 1/2
30PPCWSC467	GN 1/3
60PPCWSC467	GN 1/6

SafeTrak™ GN Food Pans

Eliminate waste, reduce risk, and simplify compliance with built-in labelling for safer storage!

Convenient & hygienic way to label, store, and serve.

- Permanently moulded-in label will never peel, fade, or smudge.
- HACCP-compliant design allows you to write key traceability information straight onto the pan for safe and consistent food tracking.
- 6 colour-coded translucent seal covers help prevent cross-contamination by clearly identifying food types. No more lost colour clips.
- Temperature range: -40°C - 85°C.
- Dish washing is safe up to 93°C.

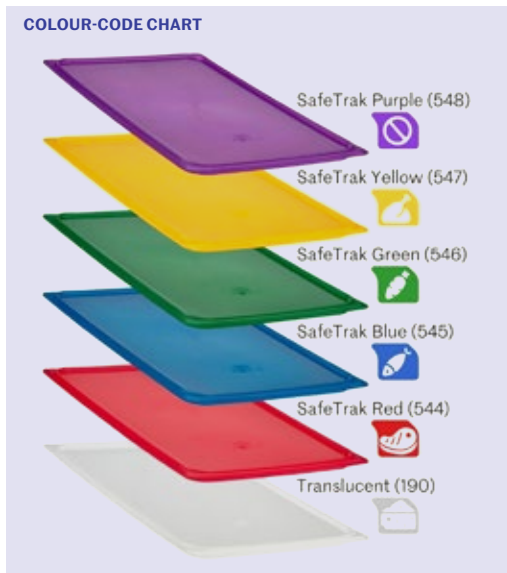

PERMANENTLY MOULDED-IN LABEL FOR FOOD SAFETY COMPLIANCE



SAFETRAK PEN DOES NOT SMUDGE DURING USE BUT COMES OFF WHEN WASHED

SafeTrak™ Gastronorm Pans Translucent GN pans made from FDA-Approved, BPA-, BPS-, and PFAS-compliant material provide at-a-glance visibility. GN size chart page 163. Add colour code for ordering.

1/1	12PPT	D65mm
	14PPT	D100mm
	16PPT	D150mm
1/2	18PPT	D200mm
	22PPT	D65mm
	24PPT	D100mm
	26PPT	D150mm
1/3	28PPT	D200mm
	32PPT	D65mm
	34PPT	D100mm
1/4	36PPT	D150mm
	38PPT	D200mm
	42PPT	D65mm
1/6	44PPT	D100mm
	46PPT	D150mm
	62PPT	D65mm
1/9	64PPT	D100mm
	66PPT	D150mm
	92PPT	D65mm
	94PPT	D100mm

SafeTrak™ Seal Covers Available in a six lid HACCP-recommended colours. Add colour code for ordering.

10PPCWSC	1/1
20PPCWSC	1/2
30PPCWSC	1/3
40PPCWSC	1/4
60PPCWSC	1/6
90PPCWSC	1/9

SafeTrak™ Pen

STP10000	Anti-Smudge Pen
----------	-----------------

SEAL COVERS MAXIMISE FRESHNESS & EXTEND SHELF LIFE BY 2 DAYS

ColdFest® Pans

ColdFest Gastronorm Pans & Crock

26CF	GN 1/2	6L
36CF	GN 1/3	3.5L
66CF	GN 1/6	1.4L
CFR18	Round Crock	1.6L

ColdFest Covers

20CFC	Cover for 26CF
30CFC	Cover for 36CF
60CFC	Cover for 66CF
CFRC18	Cover for CFR18



CONFORMS TO GASTRONORM EXTERIOR DIMENSIONS

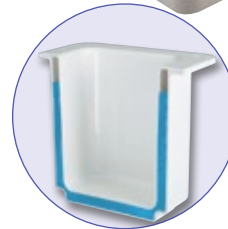

ABS MATERIAL WITH NON-TOXIC REFRIGERANT GEL CORES

- Stackable.
- Clear covers.
- Maintain at a temperature between 1 and 4°C for 6 to 8 hours (without ice) according to the model.

Polycarbonate Camwear® Food Storage Boxes



- Made of virtually unbreakable polycarbonate.
- Crystal clear for identification at a glance.
- Withstands temperatures of -40°C to 99°C, allowing use in refrigerators or freezers.
- Extend the freshness of food by transferring products into Camwear® Boxes upon receipt.
- Smooth surfaces make them easy to clean.



Camwear® Polycarbonate Food Storage Boxes

A 12183CW	6.6L	305 x 460 x D90mm
12186CW	11.4L	305 x 460 x D150mm
12189CW	18L	305 x 460 x D230mm
18263CW	18.9L	460 x 660 x D90mm
18266CW	33.1L	460 x 660 x D150mm
B 18269CW	49.2L	460 x 660 x D230mm
182612CW	64.4L	460 x 660 x D300mm
182615CW	83.3L	460 x 660 x D380mm

Camwear® Polycarbonate Covers

C 1218CCW	
1826CCW	

Sliding Lid

1218SCCW	
D 1826SCCW	



Polypropylene CamRound™ FreshPro Containers

new

Brand new durable round containers for easy scooping, precise pouring, extended shelf life, and space-saving storage!

FreshPro CamRounds' circular form helps chefs to scoop, pour, and mix with ease, speeding up prep, reducing waste, and ensuring every ingredient is fully utilised.

- **Material:** Translucent, BPA-free for durability and easy content visibility.
- **Temperature Range:** -40°C to 85°C for flexible use from walk-ins to warm prep lines.
- **Ergonomics:** Easy-carry moulded-in handles and smooth interior facilitate comfortable transport and effortless stirring.

- **Smooth Pouring:** Angled rims guide and four-sided so liquids pour precisely into pots, pans, or other containers.
- **Effortless Mixing:** Curved walls foster even whisking and folding without splatter.
- **Precision Spout:** Built-in pour spout channels sauces evenly without tipping the entire container.
- **Space-Saving:** FreshPro CamRounds stack neatly on top for maximum storage density.
- **Cleanup:** Commercial dishwasher safe for hygienic washing and fast turnaround.



FOOD STORAGE



Polypropylene CamRound™ FreshPro Containers

2RFSPROPP	1.9L	191 x 191 x 107mm
4RFSPROPP	3.8L	191 x 191 x 206mm
6RFSPROPP	5.7L	229 x 229 x 206mm
8RFSPROPP	7.6L	229 x 229 x 264mm
12RFSPROPP	11.4L	289 x 289 x 226mm
18RFSPROPP	17.2L	289 x 289 x 338mm
22RFSPROPP	20.8L	289 x 289 x 412mm

CamRound™ FreshPro Drain Shelves

2RFSFPDPP	Green	Fits 1.9L, 3.8L
6RFSFPDPP	Red	Fits 5.7L, 7.6L
12RFSFPDPP	Blue	Fits 11.4L, 17.2L, 20.8L

Seal Covers for FreshPro CamRounds™

2SFSFPDPP	Green	Fits 1.9L, 3.8L
6SFSFPDPP	Red	Fits 5.7L, 7.6L
12SFSFPDPP	Blue	Fits 11.4L, 17.2L, 20.8L

Polypropylene CamRound™ FreshPro Pails with Bails Containers

Easily store, handle, and transport ingredients! The FreshPro Pail with Bail offers ergonomic carrying, pouring, and transporting of heavy ingredients, liquids, beverages, and ice.

- Ideal for one-hand lifting of large quantities and drip-free pouring.
- Available in 12 qt, 18 qt and 22 qt sizes to handle stocks, sauces and bulk preps.
- Balanced form and a precision spout guide liquids smoothly, even at full capacity for complete pour control.
- Move more product in a single load to streamline workflows.
- Paired with the FreshPro Seal Cover, this storage container system helps prevent spills and leakage in storage and transportation applications.
- Perfect for Freezer, Cooler and Dry Storage.

Polypropylene CamRound™ FreshPro Pails With Bails Containers

PWB12PROPP	11.4L	289 x 289 x 226mm
PWB18PROPP	17.2L	289 x 289 x 338mm
PWB22PROPP	20.8L	289 x 289 x 412mm



PAIL WITH BAIL HANDLES OFFER PRECISE POUR CONTROL





CamSquare® FreshPro Polypropylene Containers

Revolutionise your kitchen with new FreshPro Series Food Storage Containers, made from durable Camwear®.

new

- **Material:** Translucent, BPA-free for durability and easy content visibility.
- **Temperature Range:** -40°C to 85°C for flexible use from walk-ins to warm prep lines.
- **Ergonomics:** Moulded-in, recessed handles save space and promote safe, comfortable handling.
- **Pouring:** Square corners enable controlled, precise pouring and quick cleanup.

- **Visibility & Measurement:** Bold graduations align with colour-coded Seal Covers and drain shelves.
- **Space-Saving:** Space-efficient square shape; stacks securely to maximise storage density. 25% more storage capacity with 17.2 and 20.8L containers.
- **Compatibility:** Shares colour-coded Seal Covers with FreshPro CamRounds and inter-stacks when covered.
- **Cleanup:** Commercial dishwasher safe for fast, reliable turnaround.



FOOD STORAGE



DRAIN SHELVES & SEAL COVERS MAXIMISE FRESHNESS & EXTEND SHELF LIFE BY

2 DAYS



FRESHPRO CAMSQUARES® & CAMROUNDS™ SHARE LIDS, STACK TO SAVE SPACE.

CamSquare® FreshPro Polypropylene Containers

2SFSPROPP	1.9L	191 x 191 x 98mm
4SFSPROPP	3.8L	191 x 191 x 183mm
6SFSPROPP	5.7L	229 x 229 x 180mm
8SFSPROPP	7.6L	229 x 229 x 243mm
12SFSPROPP	11.4L	289 x 289 x 216mm
18SFSPROPP	17.2L	289 x 289 x 327mm
22SFSPROPP	20.8L	289 x 289 x 401mm

CamSquare® FreshPro Drain Shelves

SFC2FPPP	Green	Fits 1.9L, 3.8L
SFC6FPPP	Red	Fits 5.7L, 7.6L
SFC12FPPP	Blue	Fits 11.4L, 17.2L, 20.8L

Seal Covers for FreshPro CamSquares®

2SFSPDPP	Green	Fits 1.9L, 3.8L
6SFSPDPP	Red	Fits 5.7L, 7.6L
12SFSPDPP	Blue	Fits 11.4L, 17.2L, 20.8L

COLOUR TRANSLUCENT (190) FOR ORDERING PURPOSES.

CamSquare® FreshPro Mini Polypropylene Containers

Small quantity food storage finally has a reusable alternative, thanks to ½ qt. and 1 qt. CamSquares FreshPro Series containers. Ideal for storing spice blends, fresh herbs and more.

- Durable, sustainable alternative to single-use, disposable containers.
- Small enough for one-handed carry and easily stackable.
- Translucent walls allow for quick inventory.
- Withstands -40°C to 70°C.
- One easy seal cover fits both container sizes.
- Stain, acid and odour resistant.
- Dishwasher safe.

CamSquare® FreshPro Mini Polypropylene Containers

HFSFSPROPP	0.47L	124 x 124 x 65mm
1SFSPROPP	0.9L	124 x 124 x 119mm

FreshPro Seal Covers for Mini Series

SFC1FPP	Translucent	Fits 0.47L & 0.9L
---------	-------------	-------------------

ONE COVER FITS BOTH CONTAINER SIZES



ONE-HANDED CARRYING



PREPPING & COOKING MADE EASY

Classic CamSquare® Polycarbonate Containers

- Use to maximise storage of ingredients in kitchens, coolers, freezers or pantries.
- Inventory-at-a-glance with easy-to-read colour graduations on the outside.
- Colour-coded snap-tight polyethylene covers match graduation colours and feature thumb tabs for easy removal.
- Made of crystal clear, virtually unbreakable Camwear® polycarbonate.
- Smooth surfaces for easy cleaning.
- Withstands temperatures -40°C - 99°C.
- Stackable, saving valuable space when not in use.



Classic CamSquare® Polycarbonate Containers

2SFSCW	1.9L	185 x 185 x D100mm
4SFSCW	3.8L	185 x 185 x D187mm
6SFSCW	5.7L	215 x 215 x D185mm
8SFSCW	7.6L	215 x 215 x D230mm
12SFSCW	11.4L	256 x 310 x D210mm
18SFSCW	17.2L	256 x 310 x D320mm
22SFSCW	20.8L	256 x 310 x D400mm

CamSquare® PolyCovers

SFC2	Kelly Green
SFC6	Winter Rose
SFC12	Midnight Blue

Seal Covers

SFC2SCPP	Translucent
SFC6SCPP	Translucent
SFC12SCPP	Translucent

Allergen-Safe Classic CamSquares® Polycarbonate Containers

Maximise your food storage and increase allergen food safety!

- Designate Allergen-Free ingredients.
- A crystal-clear design is outstanding for at-a-glance inventory, yet clearly labelled for allergen-free use in fast-paced kitchens.
- Easy-to-identify purple graduations and Allergen-Free imprint on the opposite side.
- Smooth surfaces for easy cleaning.
- Withstands temperatures -40°C - 99°C.
- Purple Seal covers feature an inner and outer seal to help keep ingredients safe from cross-contamination, even during transport.



Allergen-Safe Polycarbonate CamSquares®

2SFSCW441	1.9L	185 x 185 x D100mm
4SFSCW441	3.8L	185 x 185 x D187mm
6SFSCW441	5.7L	215 x 215 x D185mm
8SFSCW441	7.6L	215 x 215 x D230mm
12SFSCW441	11.4L	256 x 310 x D210mm

Allergen-Safe CamSquare® Seal Covers

SFC2SCPP441	Fits 1.9L & 3.8L
SFC6SCPP441	Fits 5.7L & 7.6L
SFC12SCPP441	Fits 11.4L



High Heat Measuring Jug

- The measuring jug that can stand the heat.
- Made from heat-tolerant plastic, these jugs can withstand temperatures up to 190°C without compromising performance, making them safe for use in microwaves or ovens.
- Use the High Heat Measuring Jug to collect coffee or hot water from a dispenser, to fill chafing dishes or steam tables, to drain hot oil from a fryer, or with soups, broth or stews in a kettle.
- Ideal for microwaves, ovens, kettles, and hot water dispensers.
- Optional splatter-proof cover protects user and surfaces.
- Translucent amber colour allows at-a-glance inventory.
- Integrated handle stays cool to the touch.
- 75% lighter than a glass measuring jug.
- Will not bend or dent for lasting use.

High Heat Measuring Jugs

200MCH	1.9L	H162mm	Ø190mm
400MCH	3.8L	H263mm	Ø190mm

Splatter-Proof Cover Self-venting. Protects against hot spills and splashes.

MCCH	Fits both sizes
------	-----------------



WITHSTANDS
TEMPERATURES FROM
-40°C TO 190°C



SPLATTER-PROOF COVER
FITS BOTH SIZES

Allergen-Safe Camwear® Measuring Jugs

- Reduce the risk of cross-contact and accidental exposure to allergens during the preparation process.
- Externally marked purple graduations and Allergen-Free logo are imprinted in Allergen purple for easy identification.

Allergen-Safe Camwear® Measuring Jugs

100MCCW441	1L
200MCCW441	2L



Camwear® Measuring Jugs

- Externally marked graduations are moulded and imprinted in imperial and metric standard.
- Durable, virtually unbreakable Camwear polycarbonate will not dent, ensuring an accurate measurement every time.
- Moulded-in handle will not break off.

Camwear® Measuring Jugs

25MCCW	225ml	200MCCW	2L
50MCCW	0.5L	400MCCW	4L
100MCCW	1L		



Pizza Dough Boxes



NEW
600X400MM
SIZES

Pizza Dough Boxes

DB60407	Polyethylene	400 x 600 x D70mm
DB604010	Polyethylene	400 x 600 x D100mm
DB18263P	Polypropylene	460 x 660 x D76mm

Dough Box Accessories

DB6040C	Dough Box Cover	400 x 600mm
DBC1826P	Dough Box Cover	460 x 660mm
CD1826PDB	Camdolly	505 x 710 x H260mm

Polycarbonate Scoops



Polycarbonate Scoops

Made of clear, virtually unbreakable polycarbonate for long-lasting durability.

SCP6CW	170g
SCP12CW	340g
SCP24CW	680g
SCP64CW	1814g

Ingredient Bins



- Store bulk dry ingredients such as flour and grain.
- Hygienic clear sliding lid reduces handling and allows for quick content identification.
- Bin made of FDA-accepted material so no liners are needed.
- Designed to fit under standard work tables.
- Hook provided for hanging Ingredient Scoop.



Ingredient Bins FDA-approved polyethylene one-piece body with a transparent polycarbonate cover. Features 2 fixed and 2 swivel Ø76mm casters. Scoops not included.

A IBS20	81L	330 x 750 x H710mm
B IBS27	102L	420 x 750 x H710mm
C IBS37	140L	550 x 750 x H710mm
D IBSF27	102L	330 x 765 x H725mm

Saf-T-Scoop® & Guardian™ System

- Germ -Guards™ protect ice from contact with hands.
- Guardian™ provides safe, dedicated scoop storage.
- Flexible mounting options.
- The Scoop dome allows mounding of ice without spilling, reducing the number of scoops to fill Ice Totes by up to 50%.

Saf-T-Scoop® & Guardian™ System Included mounting tools: (1) Mounting Bracket, (2) Wire Hanging Brackets and (2) Suction Cups.

CODE	DESCRIPTION
SI5000EUR	Scoop & Guardian 6-10 oz. (177-295 ml)
A SI7000	Scoop & Guardian 12-16 oz. (355-473 ml)
SI9000EUR	Scoop & Guardian 64-86 oz. (1.9-2.5 L)



Saf-T-Ice® Scoop Caddy

- Dedicated, sanitary ice scoop storage.
- Works with ice scoops up to 86 ounces.
- Durable construction; dishwasher safe.
- Easily removed from mounting for cleaning.

Saf-T-Ice® Scoop Caddy

CODE	COLOUR	W X D X H
SI2000	Blue	231 x 204 x 287mm



Light Duty Ice Tote

- Attaches to ice bin for faster, easier filling.
- Hanging hooks and wall bracket for easy drying.
- Dual-grip™ design provides secure handling options for improved ergonomics.
- Blue colour immediately identifies it's use as a dedicated ice container.
- Integrated Handi-Hook™ to hang on shelving.
- Recessed bottom raises handling area off the floor keeping bottom surface clean.
- Non-nesting design.

Light Duty Ice Tote

CODE	CAPACITY	COLOUR
SILD6000	22.7L	Blue



Saf-T-Ice Tote



SAFE-T-ICE TOTE AND CART SOLD SEPARATELY



2 ICE TOTES AND CART



FOOD STORAGE

Saf-T-Ice Tote Dedicated ice-only tote keeps ice protected and prevents contamination. Polycarbonate construction with stainless steel cushion grip handle. Convenient storage hook fits to ice machine for safe, easy transfer. Dishwasher safe.

CODE	DESCRIPTION
SI6100	18.9L Saf-T-Ice Tote
SI6000	22.7L Saf-T-Ice Tote
SI6500	Snap-tight Lid
SICART60	Cart for 2 x Ice Tote SI6000

SlidingLid™ Ice Caddies & Drain Grate

- Polyethylene body and thick foam insulation hold ice for days.
- Will not crack, dent, bubble, chip or break.
- Unique lid slides back and under, reducing risk of cross-contamination.
- Recessed well & drain shelf keeps ice out of water & extends hold times.
- Moulded-in handles ease manoeuvring.
- Heavy-duty front castors and large rear wheels ensure smooth transporting.
- Fits under prep tables and work counters.
- Easy to clean.
- No assembly required.

SlidingLid™ Ice Caddies

CODE	CAPACITY	W x D x H
ICS100L	46kg	570 x 770 x 730mm
ICS125L	57kg	585 x 800 x 745mm
ICS175L	80kg	610 x 955 x 745mm

Ice Caddy Drain Grate Say goodbye to watery ice. The Ice Caddy Drain Grate, paired with a Cambro SlidingLid Ice Caddy, boosts ice retention up to 24 hours and lets operators scoop clean ice without slush—enhancing drinks and reducing waste. Sold separately from the ice caddy. Commercial dishwasher safe.

CODE	W x D x H
ICSD	588 x 372 x 49mm



SIMPLY PLACE AT THE BOTTOM OF YOUR ICE CADDY WITH THE FLAT SIDE FACING UP

Featured Brands

pujadas
A VOLLRATH COMPANY

VOLLRATH

winco

Cookware & Bakeware

A great chef never blames their tools, and with our cookware, they never need to. Commercial kitchens demand high-quality cookware that performs consistently under the busiest conditions. Our products heat evenly, are non-reactive to taste and colour, and are easy to clean. With styles suitable for induction, gas, vitroc ceramic, or electric cookers, our extensive range of cooking and baking solutions has everything you need to create with confidence.



INOX FIRST	
Stainless Steel Cookware	180
Fry Pans	181
INOX-PRO	
Stainless Steel Cookware	182
Fry Pans	185
Woks	187
Paella Pans	187
BLACK SERIES Cookware	188
BLACK PRO Cookware	189
GN Grill Trays	190
Bun Pans	190
Wire Grates	190
Roast Pans	190
Egg Pan	191
Confectionery Trays	191
Oven Grids	191
Pizza Screens & Pizza Pans	191

INOX FIRST Stainless Steel Cookware

INOX FIRST Cookware – Fast, even heat and lasting durability. Stainless steel with an encapsulated aluminum core, induction-ready, and easy to clean. Sleek, ergonomic, and built to elevate your cooking.

- Full induction base for maximum heat transfer.
- Robust and insulating handles made from stainless steel tubing.
- Handles joined with 2 or 4 rivets for maximum strength and safety.
- Stainless steel construction, designed for professional use.
- Encapsulated diffuser base to ensure fast and even heat transfer.

COOKWARE & BAKEWARE



Stock Pot without Lid

455120	Ø200mm	D180mm	5.6L
455124	Ø240mm	D200mm	9.0L
455128	Ø280mm	D240mm	14.7L
455132	Ø320mm	D320mm	22.6L
455136	Ø360mm	D360mm	36.6L
455140	Ø400mm	D400mm	50.2L



Sauce Pot without Lid

455220	Ø200mm	D130mm	4L
455224	Ø240mm	D140mm	6.3L
455228	Ø280mm	D160mm	9.8L
455232	Ø320mm	D180mm	14.4L
455236	Ø360mm	D210mm	21.4L
455240	Ø400mm	D250mm	31.4L



Casserole without Lid

455320	Ø200mm	D80mm	2.5L
455324	Ø240mm	D95mm	4.3L
455328	Ø280mm	D110mm	6.7L
455332	Ø320mm	D130mm	9.2L
455336	Ø360mm	D140mm	14.2L
455340	Ø400mm	D160mm	20L



INOX FIRST Stainless Steel Cookware



Paella Pan without Lid

455420	Ø200mm	D60mm	0.9L
455424	Ø240mm	D60mm	2.7L
455428	Ø280mm	D60mm	3.7L
455432	Ø320mm	D60mm	6.1L
455436	Ø360mm	D70mm	7L
455440	Ø400mm	D80mm	10L



French Style Saucepan

455512	Ø120mm	D70mm	0.75L
455514	Ø140mm	D75mm	1.12L
455516	Ø160mm	D80mm	1.7L
455518	Ø180mm	D80mm	2L
455520	Ø200mm	D85mm	2.5L



INOX FIRST Lids

455020	Ø200mm	455032	Ø320mm
455024	Ø240mm	455036	Ø360mm
455028	Ø280mm	455040	Ø400mm



INOX FIRST Non-stick Fry Pan

- Riveted tubular handle in stainless steel.
- Non-stick coating with full induction base.
- Encapsulated diffuser base for fast, even heat distribution and improved cooking efficiency.



INOX FIRST Non-stick Fry Pan

459018	Ø180mm	D50mm
459020	Ø200mm	D50mm
459022	Ø220mm	D50mm
459024	Ø240mm	D50mm
459026	Ø260mm	D50mm
459028	Ø280mm	D50mm
459032	Ø320mm	D55mm
459036	Ø360mm	D55mm

INOX FIRST EXPERT Fry Pan

- Riveted tubular handle in stainless steel.
- Full induction base - no coating.
- Encapsulated diffuser base for fast, even heat distribution and improved cooking efficiency.



INOX FIRST EXPERT Fry Pan

413018	Ø180mm	D50mm
413020	Ø200mm	D50mm
413022	Ø220mm	D50mm
413024	Ø240mm	D50mm
413026	Ø260mm	D50mm
413028	Ø280mm	D50mm
413032	Ø320mm	D55mm
413036	Ø360mm	D55mm

INOX-PRO

DESIGNED TO ACHIEVE THE BEST PERFORMANCE IN PROFESSIONAL COOKING

CLASS
INDUCTION



COOKWARE BODY MADE OF 18/10 STAINLESS STEEL



COOKWARE & BAKEWARE



Stock Pot without Lid

218020	Ø200mm	D200mm	6.2L
218024	Ø240mm	D240mm	10.0L
218028	Ø280mm	D280mm	16.5L
218030	Ø300mm	D300mm	21.2L
218032	Ø320mm	D320mm	24.0L
218035	Ø350mm	D350mm	33.6L
218040	Ø400mm	D400mm	50.0L
218045	Ø450mm	D450mm	72.0L

Casserole without Lid

217020	Ø200mm	D80mm	2.5L
217024	Ø240mm	D95mm	4.3L
217028	Ø280mm	D110mm	6.7L
217030	Ø300mm	D120mm	8.4L
217032	Ø320mm	D125mm	10.0L
217035	Ø350mm	D140mm	13.6L
217040	Ø400mm	D155mm	19.5L
217045	Ø450mm	D170mm	27.0L



INOX-PRO Stainless Steel Cookware

CLASS
INDUCTION



Sauce Pot without Lid

216020	Ø200mm	D130mm	4.0L
216024	Ø240mm	D140mm	6.3L
216028	Ø280mm	D175mm	10.2L
216030	Ø300mm	D180mm	12.7L
216032	Ø320mm	D190mm	15.2L
216035	Ø350mm	D210mm	20.2L
216040	Ø400mm	D250mm	31.4L
216045	Ø450mm	D280mm	44.5L



Paella Pan without Lid

205024	Ø240mm	D60mm	2.7L
205028	Ø280mm	D60mm	3.7L



Steam Pot with Lid

244024	A Ø240mm	D140mm	6.3L
	B Ø240mm	D140mm	6.3L
244028	A Ø280mm	D175mm	10.0L
	B Ø280mm	D175mm	10.0L
244032	A Ø320mm	D190mm	15.0L
	B Ø320mm	D190mm	15.0L



Stock Pot with Tap and Lid

248028	Ø280mm	D280mm	16.5L
248032	Ø320mm	D320mm	24.0L
248035	Ø350mm	D350mm	33.6L



Lid

209014	Ø140mm	209030	Ø300mm
209016	Ø160mm	209032	Ø320mm
209018	Ø180mm	209035	Ø350mm
209020	Ø200mm	209040	Ø400mm
209024	Ø240mm	209045	Ø450mm
209028	Ø280mm		



COOKWARE & BAKeware

French Style Saucepan

200012	Ø120mm	D70mm	0.7L
200014	Ø140mm	D70mm	1.0L
200016	Ø160mm	D75mm	1.5L
200018	Ø180mm	D90mm	2.3L
200020	Ø200mm	D100mm	3.1L
200024	Ø240mm	D120mm	5.4L



Saucepan with Side Spouts

200116	Ø160mm	D75mm	1.5L
200120	Ø200mm	D100mm	3.1L



Deep Saucepan

202016	Ø160mm	D110mm	2.1L
202018	Ø180mm	D120mm	3.0L
202020	Ø200mm	D130mm	4.0L



Conical Sauté Pan

214018	Ø180mm	D60mm	1.2L
214020	Ø200mm	D65mm	1.6L
214024	Ø240mm	D75mm	2.7L



Sauté Pan

204020	Ø200mm	D60mm	1.9L
204024	Ø240mm	D60mm	2.7L
204028	Ø280mm	D60mm	3.7L
204030	Ø300mm	D60mm	4.3L



Fry Pans



Handles

ERGOS: Made of st/steel tube with an exclusive, heat-resistant, ergonomic design. The best performance with professional use.

HERCULES: Traditional handles made of flat iron with a heat resistant "EPOXY" coating. Highly recommended for intensive use.

Non-stick Coatings

Aluminium Fry Pans: Non-stick professional multi-layer coating applied on the 4mm thick fry pans. Long-lasting and high resistance to abrasion.

St/Steel Fry Pans: Duroolith, professional non-stick coating free of PFOA. It delivers exceptional performance thanks to its advanced three-layer system with a unique multipolymer blend. Its durable and slightly textured surface ensures maximum longevity and excellent food release.

Induction Fry Pans

Stainless Steel Non-Stick "ERGOS" Fry Pans Sandwich Bottom. 6.5mm thick.

220020	Ø200mm	D38mm
220024	Ø240mm	D46mm
220028	Ø280mm	D55mm
220032	Ø320mm	D60mm
220036	Ø360mm	D60mm



Aluminium Non-Stick induction Fry Pan "HERCULES" Non-stick professional multi-layer coating, 4mm thick.

128920	Ø200mm	D40mm
128924	Ø240mm	D45mm
128928	Ø280mm	D50mm
128932	Ø320mm	D55mm



STAINLESS STEEL INDUCTION BOTTOM

Fry Pan

Aluminium Non-Stick Fry Pan "HERCULES" Easy to Clean. 4mm thick.

128018	Ø180mm	D40mm
128020	Ø200mm	D40mm
128024	Ø240mm	D45mm
128026	Ø260mm	D50mm
128028	Ø280mm	D50mm
128032	Ø320mm	D55mm
128036	Ø360mm	D60mm
128040	Ø400mm	D65mm



Blinis Fry Pan

Aluminium Non-Stick Blinis Fry Pan Designed for cooking fried eggs. 4mm thick.

139012	Ø120mm	D20mm
--------	--------	-------



Crepe Fry Pan

Aluminium Non-Stick Crêpe Fry Pan "HERCULES" 4mm thick.

131026	Ø260mm	D25mm
--------	--------	-------



Sauté Fry Pan

Aluminium Non-Stick Sauté Pan "HERCULES" 4mm thick.

148024	Ø240mm	D70mm
148028	Ø280mm	D75mm
148032	Ø320mm	D80mm



Rectangular Fry Pan

Aluminium Non-Stick Rectangular Fry Pan For Fish "ERGOS" 4mm thick.

125038	380 x 260mm	D50mm
--------	-------------	-------



Steel Fry Pans

“Lyonnaise” Steel Fry Pan 1.5mm thick.

135120	Ø200mm	D45mm
135124	Ø240mm	D50mm
135128	Ø280mm	D55mm
135132	Ø320mm	D60mm

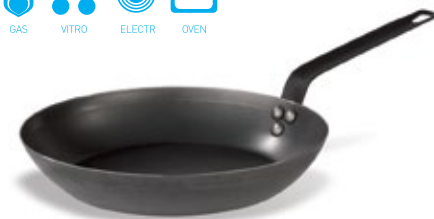

Wok

Stainless Steel Round Base Wok 0.8mm thick.

239336	Ø360mm	D100mm	6L
--------	--------	--------	----



Paella Pans

Black Steel Spanish Paella Pan

994020	Ø200mm	1 portion
994026	Ø260mm	2 portions
994030	Ø300mm	4 portions
994034	Ø340mm	6 portions
994036	Ø360mm	7 portions
994038	Ø380mm	8 portions
994040	Ø400mm	9 portions



Enamelled Steel Paella Pan

995020	Ø200mm	1 portion
995026	Ø260mm	2 portions
995030	Ø300mm	4 portions
995034	Ø340mm	6 portions
995036	Ø360mm	7 portions
995038	Ø380mm	8 portions
995040	Ø400mm	9 portions



BLACK SERIES Cookware

Non-deformable cast aluminium saucepans for even heat distribution over the entire cooking surface.



TEMPERED GLASS LIDS WITH KNOB AND HANDLE IN STAINLESS STEEL

EVEN THICKNESSES TO ENSURE EXCELLENT THERMAL CONDUCTIVITY

CAST BODY AND HANDLE IN A SINGLE PIECE



THREE-COAT SYSTEM WITH EXCELLENT ABRASION RESISTANCE AND EXTRAORDINARY LONG-LASTING NON-STICK EFFECT.

LARGE-SURFACE INDUCTION BASE FOR MAXIMUM THERMAL TRANSMISSION AND UNIFORM HEAT DISTRIBUTION



A Non-Stick Casserole without Lid

144116	Ø160mm	D50mm	0.8L
144120	Ø200mm	D60mm	1.5L
144124	Ø240mm	D70mm	2.65L
144128	Ø280mm	D75mm	3.95L
144132	Ø320mm	D80mm	5.4L
144136	Ø360mm	D85mm	7.25L
144140	Ø400mm	D85mm	8.6L

B Non-Stick Saucepot without Lid

144216	Ø160mm	D75mm	1.2L
144220	Ø200mm	D90mm	2.4L
144224	Ø240mm	D110mm	4.3L
144228	Ø280mm	D125mm	6.3L
144232	Ø320mm	D145mm	9.5L
144236	Ø360mm	D165mm	13.7L
144240	Ø400mm	D180mm	19.0L

C Non-Stick Stock Pot without Lid

144324	Ø240mm	D180mm	6.9L
144328	Ø280mm	D200mm	10.3L

D Square Non-Stick Casserole without Lid

144420	W200mm	D60mm	1.8L
144424	W240mm	D75mm	3.4L
144428	W280mm	D75mm	4.35L

E Round Glass Lid

144016	Ø160mm	144032	Ø320mm
144020	Ø200mm	144036	Ø360mm
144024	Ø240mm	144040	Ø400mm
144028	Ø280mm		

F Square Glass Lid

144420T	W200mm
144424T	W240mm
144428T	W280mm

BLACK PRO Cookware

Thick forged aluminium pans with uneven thickness for outstanding thermal conductivity, even heat distribution and high non-deformability.



THREE-COAT SYSTEM WITH EXCELLENT ABRASION RESISTANCE AND EXTRAORDINARY LONG-LASTING NON-STICK EFFECT.



ERGOS STAINLESS STEEL TUBULAR HANDLE, 3-POINT RIVETED FOR STRENGTH AND SAFETY

EVEN THICKNESS TO ENSURE EXCELLENT THERMAL CONDUCTIVITY, UNIFORM DISTRIBUTION OF HEAT AND DEFORMATION RESISTANCE

THICK INDUCTION BASE WITH A LARGE SURFACE AREA FOR MAXIMUM HEAT TRANSMISSION

A Non-Stick Fry Pan

145020	Ø200mm	D45mm
145022	Ø220mm	D50mm
145024	Ø240mm	D50mm
145026	Ø260mm	D55mm
145028	Ø280mm	D60mm
145030	Ø300mm	D60mm

B Non-Stick Wok

145128	Ø280mm	D80mm
--------	--------	-------

C Non-Stick Crêpe Fry Pan

145228	Ø280mm	D15mm
--------	--------	-------

D Non-Stick Grill Pan

145328	W280 x D280 x H50mm
--------	---------------------

E Non-Stick Hot Plate with Silicone Handles

143043	W430 x D250 x H50mm
--------	---------------------

F Non-Stick Grill Plate with Silicone Handles

143045	W450 x D270 x H50mm
--------	---------------------



RECTANGULAR INDUCTION BASE

SILICONE HANDLES INCLUDED

ROUND INDUCTION BASE

GN Grill Trays

1/1 GN size, suitable for professional oven use.

- Non-deformable cast aluminium grill.
- Highly resistant, up to 260°C in continuous use.
- Uneven thickness to ensure excellent thermal conductivity.
- Non-stick coating for improved comfort, performance and cleaning.



Non-Stick Cast Aluminium GN Grill

132501 530 x 325 x 140mm



Non-Stick Cast Aluminium Reversible GN Baking Sheet

132502 530 x 325 x 140mm

new

Bun Pans

- Impact-resistant 3004 aluminium construction.
- Tapered design for easy stacking.
- Sized to fit standard baker's racks.
- Closed bead includes galvanized non-rusting reinforcing rod.
- Concave bottom flattens during heating for even heat distribution.

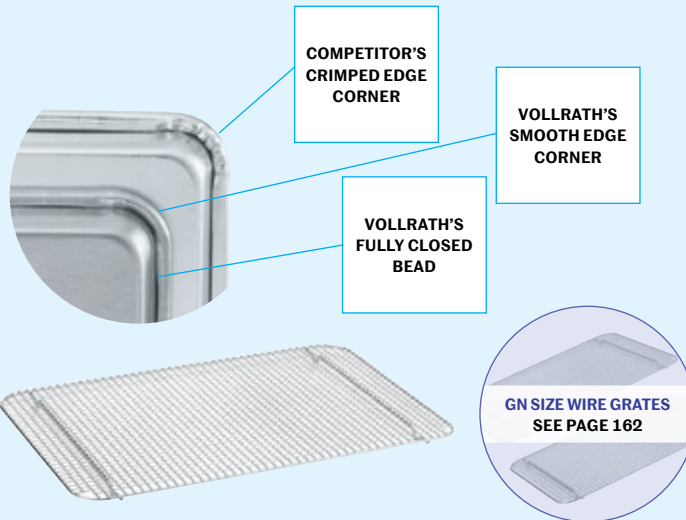

Aluminium Bun Pans

9002	Full size	650 x 450 x D25mm
9002P	Full size (perforated)	650 x 450 x D25mm
5223	Two-third size	381 x 533 x D25mm
5303	Half size	330 x 450 x D25mm
5303P	Half size (perforated)	330 x 450 x D25mm
5220	Quarter size	331 x 243 x D29mm
5228	Eighth size	241 x 162 x D28mm

Wire Grates

20038	For full size bun pan	610 x 419 x D22mm
20248	For half size bun pan	419 x 298 x D22mm



FOR MORE
BAKEWARE
PRODUCTS
VISIT FEM.CO.UK

Roast Pans, Baking Sheets & Grids



Roast Pan Falling Handles

Aluminium construction.

113035	350 x 270 x 55mm	5.0L
113040	400 x 300 x 65mm	6.3L
113045	450 x 320 x 65mm	7.6L



Non-Stick Roast Pan Falling Handles

Aluminium construction.

122040	400 x 300 x 65mm	6.3L
122050	500 x 350 x 70mm	10.8L

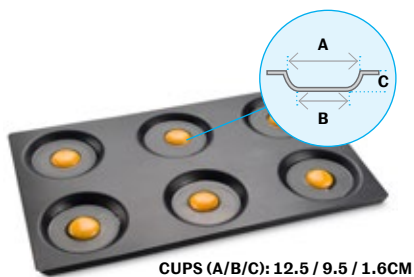

CUPS (A/B/C): 12.5 / 9.5 / 1.6CM

1/1 Non-Stick Coated Egg Pan

Aluminium construction.

132560	530 x 325mm	D16mm
--------	-------------	-------

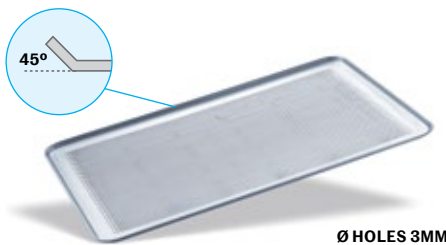

Ø HOLES 3MM

Perforated Tray for Confectionery

Aluminium construction.

123140	400 x 300mm	D12mm
123160	600 x 400mm	D12mm



Stainless Steel Oven Grid

Two Ø5mm Cross Bars and Ø2mm wires.

909340	400 x 300mm	22 wires
909360	600 x 400mm	29 wires
909111	530 x 325mm (1/1)	29 wires

Pizza Screens & Pizza Pans new



- Goes from oven to tabletop ideal for serving pizza, appetisers and more.
- Wide rim keeps fingers away from food while transporting.

Wide-Rim Aluminium Pizza Pans

APZT-9	9"
APZT-10	10"
APZT-12	12"
APZT-14	14"
APZT-16	16"



- Ideal for baking and serving oven-to-table thin crust pizzas, breads and more.
- Rolled edge improves strength of pan.

Coupe Style Aluminium Pizza Pans

APZC-9	9"
APZC-10	10"
APZC-12	12"
APZC-14	14"
APZC-16	16"



- Open mesh maximises airflow and heat transfer for faster baking and a crispy crust.

Mesh Aluminium Pizza Screens

APZS-9	9"
APZS-10	10"
APZS-12	12"
APZS-14	14"
APZS-16	16"



- 1-1/2" straight sides perfect for deep dish pizza and cakes.
- Stackable pans nest together for efficient storage.

Stackable Deep Dish Aluminium Pizza Pans

APZK-0815	8"
APZK-1015	10"
APZK-1215	12"
APZK-1415	14"
APZK-1615	16"



- Flat bottom and straight sides ensure even heating.
- Anodised aluminium is scratch resistant for long-lasting durability.

Deep Dish Aluminium Pizza Pans

HAC-082	8"
HAC-102	10"
HAC-122	12"
HAC-142	14"
HAC-162	16"



- Non-stick coating provides an even heat transfer.
- Durable heavyweight cold-rolled steel.

Steel Sicilian Pizza Pans

SPP-1218	305 x 460 x 25mm
SPP-1616	405 x 405 x 25mm

Featured Brands



Personal Safety & Janitorial

A safe venue is a happy venue. Accidents are a major risk in any kitchen, but they can be easily managed with effective tools designed to protect staff and keep operations running smoothly. Our high-quality personal safety and janitorial supplies include a comprehensive range of hand safety gloves to keep kitchen workers safe and protected to janitorial pails and cutlery catchers that help maintain a safe, hygienic, and efficient foodservice environment. Our products support the highest standards of cleanliness and safety in every kitchen.



Cold Resistant Gloves	194-195
Heat Resistant Gloves	194-197
Steam Resistant Gloves	194-196
Pan Grabbers	194
Flame Resistant Gloves	195-196
Heat Protection Apron	196
Heat Protection Hot Pad	196
Heat Protection Silicone Gloves	197
Cut Resistant Gloves	197
Cleaning Gloves	197
Rubber Floor Mats	198
Kleen Pails	198
Cutlery Catchers	198
Air & Surface Sterilisers	199

Hand Safety



A
HANDLE FROZEN FOOD
BOXES & DRY ICE

A Frozen Food Handling Glove -18°C ❄️
Flexible foam insulated lining. Knit cuff for easy on/off. Grippy surface to easily handle frozen and icy surfaces. One size fits most.

ITEM	DESCRIPTION	SELLING QTY
FGI-OR	Frozen Food Glove	Pair



B
GOOD CHOICE FOR
BASIC NEEDS

B Heat / Freezer Mitt -18°C to 204°C for 15 sec ❄️🔥
Non-stick coating. Ambidextrous. One size fits most.

ITEM	DESCRIPTION	SELLING QTY
801SG13	330mm length	Single
801SG15	381mm length	Single
801SG17S	432mm length	Single



C
EASY ON-OFF
FOR SAUTÉING

C Pan Grabber 260°C for 30 sec 🍳🔥
A handy tool for baking and cooking with hand insert for added protection. Machine washable.

ITEM	DESCRIPTION	SELLING QTY
835PG	254 x 279mm	Single



D
FULL ARM HEAT
PROTECTION

D RotissiGuard Glove Up to 260°C for 15 sec 🍷🔥
Excellent protection against heat and hot liquids. One size fits all. 5 finger dexterity.



ITEM	DESCRIPTION	SELLING QTY
T1212	305mm length	Pair
T1217	432mm length	Pair



E
EXTREME HOT OIL
PROTECTION

E FryGuard Mitt Up to 260°C for 15 sec 🍳🔥
Fully insulated. Seamless construction. Very flexible.



ITEM	DESCRIPTION	SELLING QTY
6786RMT	Neoprene® rubber – 356mm	Pair
6786RMT-XL	Neoprene® rubber – 431mm	Pair

F BestGuard® WebGuard Mitt **Up to 232°C for 30 sec**  

Non-stick coating. Ambidextrous. One size fits most.



ITEM	DESCRIPTION	SELLING QTY
800FG13	330mm length	Pair
800FG15	381mm length	Pair
800FG17	432mm length	Pair
800FG24S	610mm length	Single

Item numbers are for tan mitts. To specify black mitts add BK to the code.

G SteamGuard Mitt **260°C for 30 sec**  



Ambidextrous. Machine washable. One size fits most.

ITEM	DESCRIPTION	SELLING QTY
817TMSB	432mm length	Pair

H BestGrip® Oven Mitt **Up to 260°C for 60 sec**  

Made with WebGuard™. Built-in magnet storage system. Rinses clean. Ambidextrous. One size fits most.

ITEM	DESCRIPTION	SELLING QTY
810CM15	381mm length – Conventional	Single
810CM17	432mm length – Conventional	Single
810PM15	381mm length – Puppet	Single
810PM17	432mm length – Puppet	Single

I UltiGrip® Oven Mitt **-78°C to 260°C for 15 sec**   

Intermittent high-heat use. Ambidextrous. Rinses clean. Machine washable. One size fits most.

ITEM	DESCRIPTION	SELLING QTY
UCMX13BK	305mm length – Conventional	Single
UCMX15BK	381mm length – Conventional	Single
UCMX17BK	432mm length – Conventional	Single
UPM15BK	381mm length – Puppet	Single
UPM17BK	432mm length – Puppet	Single

J FlexGuard™ Silicone Oven Mitt **Up to 363°C for 45 sec**  

Seamless construction protects against liquids. Dishwasher Safe.

ITEM	DESCRIPTION	SELLING QTY
FX15	15" High Temp Silicone Mitt	Single
FX17	17" High Temp Silicone Mitt	Single



Cool-Touch™

Cool Touch™ Oven Mitt

Up to 260°C for 15 sec  

Made with Kevlar® WebGuard™. Excellent high heat protection. Built-in magnet storage system. Ambidextrous. One size fits most. Machine washable.

ITEM	DESCRIPTION	SELLING QTY
CTC13	330mm length – Conventional	Single
CTC15	381mm length – Conventional	Single
CTC17	432mm length – Conventional	Single
CTC24	610mm length – Conventional	Single
CTP13	330mm length – Puppet	Single
CTP15	381mm length – Puppet	Single
CTP17	432mm length – Puppet	Single
CTP24	610mm length – Puppet	Single



Cool Touch Flame™ Oven Mitt

Up to 280°C for 30 sec   

Made with flame-retardant Nomex® and Kevlar®. Excellent high heat protection. Built-in magnet storage system. Ambidextrous. One size fits most. Machine washable.

ITEM	DESCRIPTION	SELLING QTY
KT0212	305mm length – Conventional	Single
KT0215	381mm length – Conventional	Single
KT0218	457mm length – Conventional	Single
KT0224	610mm length – Conventional	Single
KT0112K	305mm length – Puppet	Single
KT0115K	381mm length – Puppet	Single
KT0118K	457mm length – Puppet	Single
KT0124K	610mm length – Puppet	Single



EZ-Kleen™

EZ-Kleen™ Oven Mitt

Up to 232°C for 15 sec  

Removable liner. Exterior and liner are easy to wipe clean. Coated poly-cotton material. One size fits most.

ITEM	DESCRIPTION	SELLING QTY
EZK15	384mm length - Conventional	Single
EZK17	432mm length - Conventional	Single



EZ-Kleen™ Apron and Hot Pad

Up to 232°C for 15 sec  

Easy to wipe clean. Coated poly cotton.

ITEM	DESCRIPTION	SELLING QTY
EZKAPR	Apron – 640 x 710mm	Single
EZKHP88	Hot Pad – 203 x 203mm	Single

Heat Protection Silicone Gloves

Heat Protection Silicone Gloves

-40°C to 260°C

ITEM	DESCRIPTION	STYLE	SELLING QTY
A 947700	425mm length	With cotton cover	Single
B 947400	300mm length	Silicone oven mitt	Single



Cut Resistant Gloves

D-Shield™ Cut-Resistant Glove

Superior cut protection at an affordable price. Lightweight 10-gauge seamless Dyneema® knit. Ambidextrous and dependable. ANSI Level 4 cut protection. Machine washable.

ITEM	DESCRIPTION	SELLING QTY
DFG1000*	Stainless Steel Knit	Single

*SPECIFY SIZE: SMALL, MEDIUM, LARGE, EXTRA LARGE



ChopGuard with Steel Mesh

Stainless steel mesh cut-resistant glove. Non-corrosive & easy to clean. Antimicrobial wrist strap.

ITEM	DESCRIPTION	SELLING QTY
MGA515*	Stainless steel mesh	Single

*SPECIFY SIZE: SMALL, MEDIUM, LARGE, EXTRA LARGE



Neoprene® Dishwashing Glove

Up to 176°C

Designed to stand up to the toughest dish scrubbing needs. The one-piece seamless outer shell is coated with heat-resistant Neoprene® rubber for heat protection up to 176°C. This glove features a jersey inner lining for comfort and added heat protection.

ITEM	DESCRIPTION	SELLING QTY
1214	355mm length	Pair
1217EL	432mm length	Pair



Natural Rubber Floor Mats

Natural Rubber Floor Mats Prevent slipping, oil-resistant and interconnecting options available.

CODE	DESCRIPTION	W X D X H
26000	Black	900 x 1500 x 12mm
26001	Black	900 x 900 x 12mm

*900 x 900mm mats are interconnecting

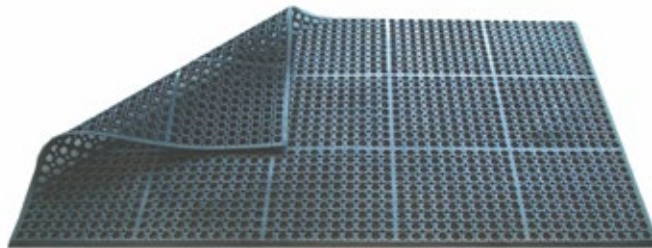

Kleen-Pail® Pro

- Colour-coded, trilingual pails for use with detergent or sanitiser.
- Curved shape and raised bottom for easy pouring.
- Moulded-in handles with embossed, raised lettering to meet health codes.
- Built-in debris-catching ribs.

Kleen Pails

CODE	DESCRIPTION	COLOUR
KPP97RD	2.84L	Red
KPP97GN	2.84L	Green
KPP196RD	5.68L	Red
KPP196GN	5.68L	Green
KPP256RD	7.57L	Red
KPP256GN	7.57L	Green
KPPS97	Stand for KPP97	Black
KPPS196	Stand for KPP196	Black
KPPS256	Stand for KPP256	Black



KatchAll® Cutlery Catchers

KatchAll® Cutlery Catchers Designed with a magnetic bar to keep cutlery from falling into the trash, eliminating costly silverware replacement expenses. Not effective with 18/8 & 18/10 stainless steel.

KA1951RD	Slim Jim
KA2000	Round 20 gallon (76L)
KA3200	Round 32 gallon (121L)
KA4400	Round 44 gallon (166.5L)



Ozone Generator Air & Surface Sterilisers

Ozone acts as a natural substance for the sterilisation of environments contaminated by bacteria, viruses, spores, mites and moulds. Ozone generators take oxygen from the air and convert it to ozone by means of electrical discharges.

O₃ Port Air & Surface Steriliser

- Portable sanitising ozone generator (O₃) with wide ABS handles for easy transportation.
- High disinfecting power at low concentrations.
- Sanitise cycle 30 minutes (1g/h for 10 m³ within 30 min).
- Timer 0-60 minutes.
- Suitable up to 100 sqm rooms.
- Dedicated to mould, bacteria and virus killing.
- Construction in anodized aluminium and Aisi 304 stainless steel.
- Low cost of use and easy to use

O₃ Port Air & Surface Steriliser

CODE	O ₃ PROD.	POWER	W X D X H
O3 PORT 10	10g/h	100w	224 x 210 x 252mm
O3 PORT 28	28g/h	200w	224 x 210 x 252mm



O₃ Tower Air & Surface Steriliser

- Floor standing sanitising ozone generator (O₃).
- High disinfecting power at low concentrations.
- Sanitise cycle 30 minutes (1g/h for 10 m³ within 30 min).
- Timer 0-60 minutes.
- Suitable up to 200 sqm rooms.
- Dedicated to mould, bacteria and virus killing.
- Construction in anodized aluminium and Aisi 304 stainless steel.
- Low cost of use and easy to use.
- O₃ MAXI TOWER: Programmable timer allows users to set the start and finish times of the sanitation procedure.
- O₃ MAXI TOWER: Sanitises up to 1440 m² making it especially suitable for large areas.

O₃ Tower Air & Surface Steriliser

CODE	O ₃ PROD.	POWER	W X D X H
A O3 TOWER 28	28g/h	200w	236 x 166 x 689mm
O3 TOWER 56	56g/h	370w	236 x 166 x 689mm
B O3 MAXI TOWER	112g/h	470w	336 x 186 x 1806mm



Featured Brands

CAMBRO
TRUSTED DURABILITYHamilton Beach
COMMERCIAL

PRINCECASTLE

pujadas
A VOLLRATH COMPANYsan jamar
smart safe sanitary

winco

VOLLRATH

Kitchen Utensils

Stir, dish, portion, ladle, turn, lift, whip, season, and serve. No matter the size of your kitchen, professional utensils are essential for efficient food preparation and serving your dishes to the highest standard. Our durable, long-lasting utensils save you time and money by standing up to the demands of a busy commercial kitchen. From colour-coded tools with antimicrobial handles to portion-control implements and dedicated allergy-prep kits, we have the right utensils to meet every need.

NSF
A22181215



Manual Can Opener	202
Grill Accessories	202
Tab Grabbers	203
Smashed Burger Press	203
Charcoal Cooking Essentials	204
Kitchen Knives	205
Cutting Boards	206
Allergen Saf-T-Zone™ System	206
Allergen Baking Mats	207
Allergen Utensils	207
Ice Cream Scoops	208
Dishers	209
Ladles	210
Spoodles	211
Tongs	212
Serving Spoons	213
Spatulas & Softspoons	213
Whisks	213
Scales	214

Side-Cut Manual Can Opener

Six turns is all you need!

- **No More Sharp Edges** - Opens seam of a can, instead of puncturing the lid with a blade, so there is no sharp edge.
- **No Cross-Contamination** - no food contact with the blade, unlike conventional can openers.
- **No Risk of Metal Shavings** - Since lid is not being cut with a blade, metal shavings won't get into the food.
- **No Gears to Wear or Break** - Removes the possibility of downtime.
- **Durable Construction** - Made of stainless steel and nickel-plated aluminum for durable performance.
- **Tough, stainless steel cutter** design with SUS420 grade material.
- **Permanently mounts to Countertop** - includes stainless steel screws.
- **Built-in Can Rest** - allows cans to rotate freely.
- **No sharp blades to replace**, and easy tool-free blade assembly replacement.
- **Designed to last and work great** - life tested on up to 5,000 cans.
- **Ease of cleaning** - pull pin quickly releases.



REMOVABLE CUTTING BLADE ASSEMBLY IS SUPER EASY TO CLEAN



RAISES AND LOWERS EASILY OVER ALL CANS TO ENSURE SAFE AND QUICK CAN OPENING



Manual Can Opener

CODE	CANS PER DAY	MATERIAL	W X D X H	BASE W X D
HCO500	50	Stainless Steel	101 x 215 x 430mm	101 x 215mm

Grillmaster® Grill Stones

- Odourless, tasteless scouring bricks that clean grills without transferring odours or flavours.
- Holder is lightweight and durable to facilitate frequent use.

Grillmaster® Grill Stones

CODE	DESCRIPTION
US-GM36	Grill Stones (Pack of 12)
US-6-8	Grill Stones Holder



GRILL STONES AND HOLDER SOLD SEPARATELY



Grill Accessories



H 161

Grill Scrapers Prevents burned product buildup. Dishwasher safe for simple cleaning.

H 161	Grill Scraper
-------	---------------



I 233-71A

Grill Wiper Removes excess grease quickly and easily. 1.78mm wide wiper strip is reversible for long life. Replacement wiper strips available.

I 233-71A	Grill Wiper
-----------	-------------



J CC

Char Brushes Cleans charcoal grills quickly and easily. Ergonomic pistol grip with coarse bristles. Replacement brush available.

J CC	Char Brush
CC-1	Brush only



Tab Grabbers

Tab Grabbers An innovative design makes Tab Grabbers the first and only that provide secure check holding and smooth sliding.

CK6512A	305mm (12")
CK6518A	458mm (18")
CK6524A	610mm (24")
CK6530A	762mm (30")
CK6536A	915mm (36")
CK6544A	1017mm (44")
CK6548A	1220mm (48")
CK6560A	1524mm (60")



Smashed Burger Press

new

Smashed Burger Press 18/8 stainless steel with red silicone sleeve. Lock in the flavour and deliver "smashed burger crust". Easy clean with unique one-piece design. Press burgers to uniform thickness for quicker cook time and consistent texture. Removable silicone sleeve is heat-resistant up to 230°C.

SWS-6	6" Diameter
-------	-------------

Charcoal Bag

High-performance charcoal developed for professional grills, charcoal ovens, and industrial kitchens. It delivers powerful, even and long-lasting combustion, ensuring consistent heat and excellent energy efficiency. With an impressive 8,000 Kcal/kg calorific value, coarse particles up to 150 mm, over 75% carbon content, less than 5% ash, and moisture below 6%, this charcoal guarantees clean burning, strong heat output, and minimal residue.

- High calorific performance: 8,000 Kcal/kg.
- Coarse, dust-free composition.
- Low ash content (<5%) and low moisture (<6%).
- Supplied in a 10 kg plastic-coated raffia bag with an integrated handle, it is easy to transport.
- Designed to prevent soot release during storage and use.



Charcoal Bag

CODE	DESCRIPTION	CAPACITY
850000	Charcoal Mixture	10kg

Firelighter Pack

- Ensures quick and reliable ignition in any setting, making it perfect for all types of firelighting.
- Made with 92% solid alcohol for a clean, controlled burn.
- Produces no smoke, sparks, or odours for a hassle-free experience.
- Leaves no residue, keeping workspaces clean and professional.
- Reduces the risk of accidents with its stable, explosion-free formula.
- 100% eco-friendly and non-toxic, safe for both people and the environment.
- Each pack includes 24 tubes, each containing 8 tablets, for a long-lasting supply.



Firelighter Pack

CODE	DESCRIPTION
852000	Firelighter Pack

Refractory Bricks for Open Grills & Robatas

- Replacement bricks for the construction of the refractory brick base.
- Rather than replace the full base - replace individual damaged/used bricks when needed.



Grillmaster® Grill Stones

CODE	DESCRIPTION
858000	Refractory Bricks - Five Pack

Acero Kitchen Knives

new



The Acero cutlery collection is crafted from forged German steel. Each knife is ice tempered for ultra-sharpness and edge retention, providing professional results that won't break the bank.

- Forged, ice tempered stainless steel holds a sharp edge.
- Full-tang construction for precise control.
- Crafted of X50 Cr Mo V15 German steel for ultimate durability.
- POM injection-moulded handle for balanced weight distribution.
- 6-spot advanced polishing allows for comfortable grip.

Chef's Knives

CODE	DESCRIPTION
KFP-60	6" Chef's Knife
KFP-80	8" Chef's Knife
A KFP-84	8" Chef's Knife, Hollow Ground
KFP-85	8" Chef's Knife, Short Bolster
KFP-100	10" Chef's Knife
KFP-103	10" Chef's Knife, Hollow Ground
B KFP-104	10" Chef's Knife, Short Bolster
C KFP-120	12" Chef's Knife

Utility Knife

CODE	DESCRIPTION
D KFP-50	5" Utility Knife



Saf-T-Grip® Cutting Board

Saf-T-Grip® Cutting Boards These boards combine quality and durability with integrated anti-slip grips to provide a safe cutting surface without using the unsanitary "wet towel" method. The unique co-polymer material withstands continual high-temperature commercial washing and will not warp.

CBG121812*	305 x 457 x 13mm
CBG152012*	381 x 508 x 13mm
CBG182412*	457 x 610 x 13mm

* Specify colour when ordering: red (RD), yellow (YL), blue (BL), green (GN), brown (BR), beige (BG), white (WH) or purple (PR)



INTEGRATED ANTI-SLIP GRIP HOLDS BOARD IN PLACE



PATENTED FOOD SAFETY HOOK FOR SANITARY TRANSPORT AND STORAGE

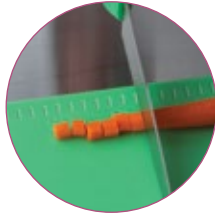

INTEGRATED RULER FEATURE MAKES PORTIONING EASY, SAVING COST



GREEN BOARD IN USE. AVAILABLE IN HACCP COLOUR-CODING TO MINIMISE CROSS-CONTAMINATION.



FULL RANGE OF SIZES/COLOURS AVAILABLE AT FEM.CO.UK

Allergen Saf-T-Zone™ System

Protect guests from food allergies by using the only system of its kind!

With food allergies on the rise, and new government regulations making foodservice providers more responsible for food allergy incidents, don't leave safe food preparation to chance. The Allergen Saf-T-Zone™ System provides the basic tools you need to minimise food allergy risks. Purple tools alert staff to follow special food allergy procedures.

How the System Works

1. Review guest allergy concerns.
2. Refer the guests' allergy information to the manager and back-of-house.
3. Respond to the guest, informing them of your operations' procedures to address their allergy concerns.
4. Remember to check the ingredient list and procedures, take every precaution to keep allergy-causing ingredients away from the prep and plate station.
5. Use The Purple Board™ as a portable prep area with tools dedicated to preparing the allergic guest's meal.
6. Wash and sanitise board and tools before next use.



Allergen Saf-T-Zone™ System

A ASZ121812SYS	12 x 18" purple cutting board 10" stainless chef knife w/ purple handle 12" stainless tongs w/ purple handle 13" stainless turner w/ purple handle
ASZKNIFE	Additional Knife
ASZTONGS	Additional Tong

*THERMOMETER NO LONGER INCLUDED WITHIN SYSTEM

ALLERGEN SAF-T-ZONE™ CASE DURABLE CASE - SECURELY PROTECTS SYSTEM TOOLS FROM CONTAMINATION DURING STORAGE.



ALLERGEN FOOD STORAGE SEE PAGE 173

Allergen-Free Purple Silicone Baking Mats

new

- Double-sided and reusable up to 2,000 times.
- Provides consistent and even heat distribution.
- Woven fibreglass coated with food-grade silicone.
- Temperature tolerance from -5°C to 225°C.



SBS-11PP



SBS-16PP

Allergen-Free Purple Silicone Baking Mats

SBS-11PP	1/4 Size
SBS-16PP	1/2 Size
SBS-21PP	2/3 Size
SBS-24PP	1/1 Size

Purple Allergen Utensils

LIMITED LIFETIME WARRANTY
HANDLE 12-MONTHS



Stainless Steel Turner
Ergo Grip™ Handles.

4808780	150 x 75mm
4808880	210 x 75mm



Basting Spoon Stainless steel
with Ergo Grip™ handle.

6414080	Solid	350ml
6414280	Perforated	350ml



Colour-coded Kool-Touch® Ladle
One-piece handles.

4980280	2oz
4980480	4oz



Spoodle Colour-coded Spoodle Round Bowl One-piece heavy-duty.

6433480	4oz	Solid
6432480	4oz	Perforated



Utility-Grip Kool-Touch® Tongs
One-piece, featuring 'utility' grip.

4780980	241mm
4781280	305mm



Colour-coded Piano Whisks
Anti-slip handle.

47002	255mm
47003	305mm
47004	355mm
47005	405mm
47006	455mm



Colour-coded Disher
Squeeze handles.

47400	3/4oz (22ml)	200mm
47378	3/4oz (22ml)	235mm



Colour-coded Disher
One-piece handles.

47147	3/4oz (22ml)
-------	--------------

Ice Cream Scoops



Ice Cream Scoop

47274	4oz	Brown
47275	3oz	Blue
47276	2½oz	Green
47277	2oz	Gold
47278	1½oz	Silver
47279	1oz	Red
47270	Spade	Blue

- Anti-freeze encapsulated in handle for easy release from scoop bowl.
- Patented ergonomic, textured handle design for a secure grip.
- Hanging hole for easy storage.
- Durable cast aluminium.
- Industry-standard bowl dimensions for consistent portioning.
- Coloured end cap to easily identify size/capacity.
- Handwashing recommended.
- The Ice Cream Spade's extended handle reaches deep into containers, preventing waste & the formation of ice crystals. Great for mixing, levelling and hand packing containers.

Colour-coded Portion Control Utensils

Save money with Portion Control!

Delivering proper nutrition and controlling your food costs demands accurate, repeatable portion sizing. The trouble is, how do you ensure that your kitchen staff and servers are using the proper size utensil? Vollrath simplifies portion control with a complete system of serving utensils, colour-coded for quick and easy size selection. Your menu calls for 2 ounces of vegetables, tell your staff to use the blue Spoodle®. Serving 4 ounces of stuffing? Use a grey disher. It's that simple. Manufactured according to rigid specifications, these utensils ensure consistency every time!

'Consistently over portioning a £6-per-pound product just 1/2 an ounce adds almost 1gp to the serving cost. If you do that 100 times a day, you lose £133 a week or almost £7,000 a year – and that's just one product.'



**AGION ZEOLITE
RELEASING
SILVER IONS**

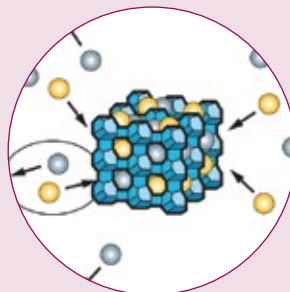

Vollrath Utensils equipped with Agion®

Fight Off Nasty Microbes

Invading microbes are a fact of life in any commercial kitchen environment. It's not hard to imagine how many of these nasty microbes can get transferred to serving utensils. And because dirty utensils and food do not get along, you need the power of Vollrath's exclusive Agion® Silver Ion Antimicrobial Technology. While untreated surfaces allow microbes to collect and multiply, microbes are attacked by the silver ions in Vollrath's antimicrobial utensils!

Fighting on all fronts at once!

Unlike chemical or man-made antimicrobials which generally interact with only one specific site on a microbe, the silver-based antimicrobial compound attacks multiple targets on the microbe:

- Prevents cell reproduction.
- Obstructs cell respiration.
- Starves the bacteria.

Dishers

agion
Nature's antimicrobial

LIMITED LIFETIME WARRANTY
*HANDLE 12-MONTHS



KITCHEN UTENSILS

MOULDED ONE-PIECE HANDLE IMPROVES DURABILITY, MAKES CLEANING EASY AND PREVENTS HANDLE FROM COMING APART

EXTENDED GROOVED HANDLE PROVIDES A SURE GRIP FOR COMFORTABLE USE

COLOUR-CODED HANDLE FOR NO-GUESS SIZE SELECTION

STAINLESS STEEL BOWL AND COMPONENTS TO PREVENT CORROSION AND INSURE LONGER LIFE

ACCURATE PORTIONS AND DISHWASHER SAFE

BLADE EXTENDS BEYOND BOWL TO PREVENT STICKING

Colour-coded Dishers One-piece handles. Colour-coded by size.

47139 5½oz White

47141 3¼oz Ivory

47143 2oz Blue

47145 1½oz Red

47147 ¾oz Purple

47140 4oz Grey

47142 2¾oz Green

47144 1¾oz Yellow

47146 1oz Black



Ladles

LIMITED
LIFETIME
WARRANTY
HANDLE 12-MONTHS



PLASTIC-COATED
HANDLES ARE HEAT
RESISTANT TO 180°F
(82°C)

GROOVED HANDLE
FOR ADDED
STRENGTH

HOOKED HANDLE TO
PREVENT SLIDING
AND FOR EASY
STORAGE

CAPACITIES CLEARLY
STAMPED ON
PRODUCT FOR EASY
IDENTIFICATION

HEAVY-GAUGE
STAINLESS STEEL
SHAFTS AND BOWLS
FOR LONGER LIFE

MIRROR-FINISHED
BOWLS, SATIN-
FINISHED HANDLES



agion

Nature's antimicrobial



A

B

C

D

A Colour-coded Kool-Touch®

Ladle One-piece heavy-duty handles. Colour-coded by size.

4980120	1oz	Black
4980230	2oz	Blue
4980335	3oz	Ivory
4980445	4oz	Grey
4980655	6oz	Teal
4980865	8oz	Orange

B Black Kool-Touch® Ladle

One-piece heavy-duty handles.

4980120	1oz
4980220	2oz
4980320	3oz
4980420	4oz
4980620	6oz
4980820	8oz

C Stainless Steel One Piece

Ladle Capacity marked on the handle.

301165	70ml
301108	120ml
301109	200ml
301110	250ml
301112	500ml
301114	750ml
301116	1L
301118	1.5L

D Camwear® Polycarbonate

Ladle Portion control bowl. Angled handle for easy access.

LD85	25ml	L216mm
LD105	30ml	L268mm

Spoodles



CAPACITIES CLEARLY STAMPED ON SHAFT FOR EASY SIZE IDENTIFICATION

ONE-PIECE CONSTRUCTION IS DURABLE AND SANITARY

TEXTURED SURFACE PREVENTS SLIPPAGE WHILE IN USE AND COLOUR-CODED FOR QUICK SIZE IDENTIFICATION

MIRROR-FINISHED STAINLESS STEEL SHAFTS AND BOWLS – RESISTANT TO CORROSION

HIGH TEMPERATURE PATENTED NYLON HANDLE – HEAT RESISTANT TO 450°F (232°C)



COLOUR-CODED BY SIZE



Spoodle Black Handle Round

Bowl One-piece heavy-duty. Available solid (S) or perforated (P).

6433120	1oz	S	£18.90
6432120	1oz	P	£18.90
6433220	2oz	S	£19.30
6432220	2oz	P	£19.30
6433320	3oz	S	£19.30
6432320	3oz	P	£19.30
6433420	4oz	S	£18.50
6432420	4oz	P	£19.80
6433620	6oz	S	£21.60
6432620	6oz	P	£21.60
6433820	8oz	S	£21.60
6432820	8oz	P	£21.60

A Spoodle Colour-coded Handle

Round Bowl One-piece heavy-duty. Solid (S) or perforated (P).

6433120	1oz	Black	S	£18.90
6432120	1oz	Black	P	£18.90
6433230	2oz	Blue	S	£19.30
6432230	2oz	Blue	P	£19.30
6433335	3oz	Ivory	S	£19.30
6432335	3oz	Ivory	P	£19.30
6433445	4oz	Grey	S	£19.80
6432445	4oz	Grey	P	£19.80
6433655	6oz	Teal	S	£21.60
6432655	6oz	Teal	P	£21.60
6433865	8oz	Orange	S	£21.60
6432865	8oz	Orange	P	£21.60

B Spoodle Colour-coded Handle

Oval Bowl One-piece heavy-duty. Available solid (S) or perforated (P).

6412120	1oz	Black	S	£18.90
6422120	1oz	Black	P	£18.90
6412230	2oz	Blue	S	£19.30
6422230	2oz	Blue	P	£19.30
6412335	3oz	Ivory	S	£19.30
6422335	3oz	Ivory	P	£19.30
6412445	4oz	Grey	S	£19.80
6422445	4oz	Grey	P	£19.80
6412655	6oz	Teal	S	£21.60
6422655	6oz	Teal	P	£21.60
6412865	8oz	Orange	S	£21.60
6422865	8oz	Orange	P	£21.60

Kool-Touch® Tong



- Colour-coding reduces the risk of foodborne illness resulting from cross-contamination.
- Unique springless design eliminates bacteria prone food traps.
- Kool-Touch® colour-coded handles provide easy identification for controlled food contact.
- Ideal for maximising your HACCP programme.
- The handles are heat resistant up to 180°F (82°C).

KITCHEN UTENSILS

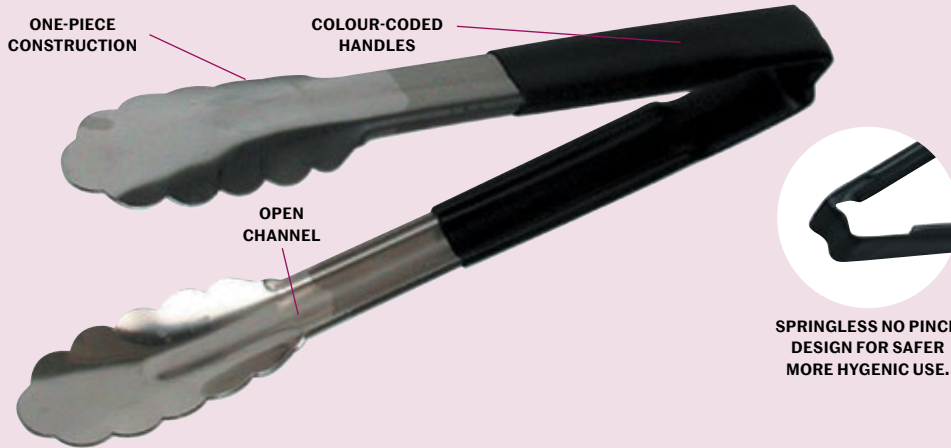

SPRINGLESS NO PINCH DESIGN FOR SAFER MORE HYGENIC USE.



UTILITY GRIP
THE UTILITY GRIP WITH CONCAVE ENDS AND GENTLY SCALLOPED TEETH IS IDEAL FOR ALMOST ANY AREA OF THE KITCHEN.



VERSAGRIP®
VERSAGRIP® FEATURES FLATTENED ENDS AND GRIPPER TEETH, PERFECT FOR GRILLS AND BROILERS.



COLOUR-CODED
COLOUR-CODED FOR QUICK IDENTIFICATION AND HELP PREVENT CROSS-CONTAMINATION. SEE BELOW FOR COLOUR GUIDE.

Utility Grip Kool Touch® Tong

One-piece, colour-coded tong featuring 'Utility' (scalloped) grip.

4780920	241mm	Black
4781220	305mm	Black
4780930	241mm	Blue
4781230	305mm	Blue
4780940	241mm	Red
4781240	305mm	Red
4780950	241mm	Yellow
4781250	305mm	Yellow
4780960	241mm	Tan
4781260	305mm	Tan
4780970	241mm	Green
4781270	305mm	Green

VersaGrip® Kool Touch® Tong

One-piece, colour-coded tong featuring 'VersaGrip®'.

4790920	241mm	Black
4791220	305mm	Black
4790930	241mm	Blue
4791230	305mm	Blue
4790940	241mm	Red
4791240	305mm	Red
4790950	241mm	Yellow
4791250	305mm	Yellow
4790960	241mm	Tan
4791260	305mm	Tan
4790970	241mm	Green
4791270	305mm	Green

MISCELLANEOUS
COOKED FOODS
RAW MEATS
UNCOOKED POULTRY
FISH
FRUIT & VEG

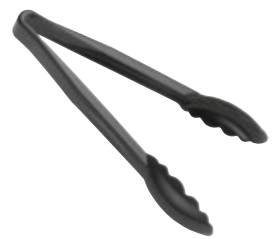

Scalloped Grip Lugano™ Tong To order Clear add 135 to the item code and for Black add 110.

6TGS	L150mm
9TGS	L230mm
12TGS	L305mm



Flat Grip Lugano™ Tong To order Clear add 135 to the item code and for Black add 110.

TG9	L230mm
-----	--------



ECONOMY ITEM

Economy Tongs

Stainless Steel two-piece spring construction.

47007	L178mm
47110	L241mm
47113	L305mm
47116	L406mm



Utility Grip Stainless Tong Heavy-duty, one-piece, stainless steel construction.

4780910	L241mm
4781210	L305mm
4781610	L406mm

Camwear® Serving Spoons



Camwear® Buffet Spoon One-piece polycarbonate construction. Available solid (S) or perforated (P). To order Clear add 135 to the item code, for Black add 110.

SPO8CW	L205mm
SPO10CW	L255mm S
SPO10CW	L255mm P

Camwear® Deli Spoon One-piece polycarbonate construction. Available solid (S) or perforated (P). To order Clear add 135 to the item code, for Black add 110.

SPO11CW	L280mm S
SPO11CW	L280mm P
SPO13CW	L330mm S
SPO13CW	L330mm P

Spatulas & Softspoons™



A Standard Spatula

Thermoplastic blade and polyprop handle retain shape up to 100°C.

52009	L244mm
52013	L346mm
52016	L422mm

B Standard Softspoon™

Thermoplastic blade and polyprop handle retain shape up to 100°C.

52109	L241mm
52113	L343mm
52116	L419mm

C High Temp Spatula

Nylon handle and silicone blade heat resistant to 260°C.

52010	L254mm
52023	L343mm
52026	L419mm

D High Temp Softspoon™

Nylon handle and silicone blade heat resistant to 260°C.

58110	L254mm
58123	L343mm
58126	L419mm

Whisks



Whisk w/Anti-slip Handle 8 x 2mm thick wires.

959025	L250mm
959030	L300mm
959035	L350mm
959040	L400mm
959045	L450mm
959050	L500mm

Heavy Whisk 8 x 2mm thick wires.

354025	L250mm
354030	L300mm
354035	L350mm
354040	L400mm
354045	L450mm
354050	L500mm

Fine Whisk 12 x 1.3mm thick wires.

316025	L250mm
316030	L300mm
316035	L350mm
316040	L400mm
613045	L450mm
316050	L500mm

Scales



Slimline Digital Scale

- Touch Screen Display.
- Low profile design.
- Large 254 x 320mm stainless steel weighing surface.
- IP65 Water Resistant and touch sensitive controls.
- High capacity scale with sensitive touch for accurate weighing.
- LED and touchscreen display for extended battery life.

Slimline Digital Scale Stainless Steel weighing surface. Water resistant front panel. LED and touch screen display. Tare feature.

CODE	CAPACITY	INCREMENTS	POWER	W X D X H
SCDGSL33	15kg	1g	Batteries Included	254 x 320 x 25mm

Digital Washdown Scale IP67 waterproof design. Backlight display. Parts counting feature. Display hold. Adaptor included.

CODE	CAPACITY	INCREMENTS	POWER	W X D X H
SCDG33WD	15kg	1g	9V A/C power adapter	210 x 265 x 95mm

Large Portion Control Digital Scale 4 display configurations. Sealed Display, Tare Feature and automatic shutoff. Adaptor Included.

CODE	CAPACITY	INCREMENTS	POWER	W X D X H
SCDGPC13	6kg	2g	9V A/C power adapter	400 x 318 x 76mm

Mechanical Scale with Bowl Tare feature. Removable stainless steel bowl. Shatterproof front panel.

CODE	CAPACITY	INCREMENTS	POWER	W X D X H
SCDLB2	1kg	5g	-	254 x 203 x 216mm
SCDLB11	5kg	20g	-	254 x 203 x 216mm



Scales

Round Professional Digital Scale Removable stainless steel platform. Simple 2 button operation. Tare feature. Automatic shutoff.

CODE	CAPACITY	INCREMENTS	POWER	W X D X H
SCDGP11BK	5kg	1g	9V A/C power Batteries included, adapter optional	216 x 152 x 42mm

Glass Digital Scale Smooth glass surface. Touch screen display. Tare feature. Display hold. Automatic shutoff.

CODE	CAPACITY	INCREMENTS	POWER	W X D X H
SCDG15BK	7kg	1g	Batteries Included	229 x 165 x 19mm

Large Square Digital Kitchen Scale Sealed display. Tare feature.

CODE	CAPACITY	INCREMENTS	POWER	W X D X H
SCDG13	6kg	1g	9V A/C power Batteries included, adapter optional	248 x 184 x 95mm

M-Series Digital Scales Display hold. Tare feature. Sealed display. Automatic shutoff.

CODE	CAPACITY	INCREMENTS	POWER	W X D X H
SCDGM33	15kg	2g	9V A/C power Batteries included, adapter optional	305 x 260 x 105mm
SCDGM66	30kg	2g	9V A/C power Batteries included, adapter optional	305 x 260 x 105mm

Industrial Digital Scale Auto shutoff. Remote display. Weigh items as percentage. Tare feature.

CODE	CAPACITY	INCREMENTS	POWER	W X D X H
SCDG264	120kg	50g	9V A/C power Batteries included, adapter optional	292 x 279 x 32mm

Optional 9V A/C power adapter Suitable for SCDGP11BK, SCDG13, SCDGM33, SCDGM66, SCDG220

CODE	POWER
9VADAP	9V A/C power adapter



Featured Brand

CAMBRO
TRUSTED DURABILITY

Trays

The humble serving tray underpins countless hospitality activities. Presentation is key to the customer experience, almost as important as the food and beverages you serve. Personalised trays can promote your brand while enhancing service, whether you're serving artisanal coffees, running a busy canteen, or delivering room service. Our high-quality trays come in a range of materials, sizes, colours, and shapes, making it easy to find the perfect tray for every need and budget.



TreadLite Non-Skip Fibreglass	218
EpicTread Non-Skid Fibreglass	219
Camtread Non-Slip Fibreglass	219
Madeira Laminated	220
Room Service Laminated	220
Capri Laminated	221
Mykonos Non-Slip Laminated	221
Versa Century Wood Grain	222
Versa Lite Polyester	223
Camtray Fibreglass	224
Fast Food Polypropylene	224
Personalisation	225

Choose the right tray for your business...

Cambro is the global leader in manufacturing trays for the food service industry, offering the largest selection of materials, sizes, colours, shapes and personalisation options for any foodservice operation. The wide selection of Cambro trays on offer make it easy to find the right tray for every need and budget.

Step 1:

What Will the Tray Be Used For?

In order to choose the correct tray, first identify the correct application for the tray.

Step 2:

Who Will Be Using the Tray?

To determine the appropriate tray material, it is critical to identify who will be using the tray.

Step 3:

How Will the Tray Be Used and Washed?

Consider how the tray will be used, and whether it will endure mild or excessive use and abuse. Determining how often the tray will be washed per day will determine which tray is best for lasting use.

Step 4:

Determine the Budget per Tray

Ensure that the correct tray has been selected for the right application. Selecting a low-cost tray for a heavy application is not the most cost-effective option. Please consider material, size, Personalisation and warranty before making your purchase.



TreadLite™ Non-Slip Fibreglass Reinforced Polyester Tray

Thick, fibreglass reinforced polyester construction with a moulded in, high-quality non-slip rubber surface. Strengthened edges provide superior strength and protection. To order Black add 110 to the item code.

1400TL	Round	Ø355mm
--------	-------	--------

1600TL	Round	Ø405mm
--------	-------	--------

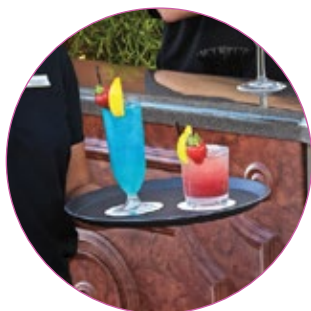

Non-Slip Surface
THE NON-SLIP SURFACE KEEPS MEALS AND BEVERAGES SAFELY IN PLACE, PROVIDING STABILITY DURING HANDLING AND SERVICE.



SPECIFICATION

SURFACE CHARACTERISTICS	RUBBER NON-SLIP
PERFORMANCE	GOOD
STACKING LUGS	YES
DISHWASHER SAFE	YES - EXTENSIVE
CHEMICAL RESISTANCE	GOOD
DRYING TEST	GOOD
SHOCK RESISTANCE	GOOD
BREAK RESISTANCE	GOOD
SCRATCH RESISTANCE	GOOD
STAIN RESISTANCE	GOOD
HEAT RESISTANCE	-10°C to +80°C

EpicTread™ Non-Skid Fibreglass Tray



ADD YOUR
LOGO SEE
PAGE 225

Heavy-duty fibreglass with durable, moulded-in, non-skid surface. Available in a vast array of stylish colours and personalisation available on the top and bottom. To order Black add 110 to the item code.

1014ET	Rectangle	270 x 350mm
1216ET	Rectangle	305 x 415mm

- Stacking lugs enhance air circulation for quick, effective, drying and perfect stacking.
- Lightweight and highly durable with a clear non-skid surface.
- Dishwasher safe.
- 2-year warranty against breakage and surface delamination under normal use.



TRAYS

Camtread® Fibreglass Tray with Non-Slip Rubber Surface



ADD YOUR
LOGO SEE
PAGE 225

Layered fibreglass and polyester resin construction with a rubber non-slip surface moulded edge to edge. Non-slip surface puts a firm grip on beverages and service items reducing spillage and breakage. Available as rectangular, round and oval tray shapes. To order Black add 110 to item code, for Tan add 138 and for Burgundy Wine add 522.

1100CT	Round	Ø280mm	1216CT	Rectangle	305 x 415mm	2900CT	Oval	735 x 600mm
1400CT	Round	Ø355mm	1418CT	Rectangle	360 x 460mm			
1600CT	Round	Ø405mm	2700CT	Oval	560 x 685mm			



Edge-To-Edge Non-Slip
THE UNIQUE CAMTREAD NON-SLIP RUBBER SURFACE PROVIDES EXTRA GRIP ON EVEN TALL FLUTED GLASSWARE. EDGE-TO-EDGE NON-SLIP MEANS EVEN WITH A FULL TRAY ITEMS AT THE EDGE MAINTAIN GRIP.



SPECIFICATION

SURFACE CHARACTERISTICS	RUBBER NON-SLIP
PERFORMANCE	EXCELLENT
STACKING LUGS	YES
DISHWASHER SAFE	YES - EXTENSIVE
CHEMICAL RESISTANCE	GOOD
DRYING TEST	EXCELLENT
SHOCK RESISTANCE	EXCELLENT
BREAK RESISTANCE	GOOD
SCRATCH RESISTANCE	EXCELLENT
STAIN RESISTANCE	GOOD
HEAT RESISTANCE	-10° TO +100°C*

Madeira Laminated Tray with Textured Surface



ADD YOUR LOGO SEE PAGE 225

Durable laminate construction with a textured surface. Introducing an upscale tray available in a variety of wood pattern finishes. To order in Dark Oak add E88 on to the item code, for Light Oak add E86 and for Light Olive E89.

MA3343 Rectangle 330 x 430mm

MA3646 Rectangle 360 x 460mm

- Lightweight, durable, and easy to clean.
- Excellent chemical, stain and scratch resistance.
- Top and bottom surface sealed with pure grade melamine.
- Stackable for easy storage.
- Dishwasher safe – wash once daily.



LIGHT OAK



LIGHT OLIVE



DARK OAK

TRAYS

Room Service Laminated Tray with Smooth Surface

ADD YOUR LOGO SEE PAGE 225

Laminate construction with a smooth surface. Introducing a contemporary room service tray that is attractive, efficient and easy to clean. To order Brushed Steel add 612 to the item code, for Venge add 384 and for Walnut add 376.

CA4064H 400 x 635mm



UP TO 50% GREATER STACKING CAPACITY THAN COMPARABLE WOOD TRAYS

LIGHTWEIGHT, WEIGHS UP TO 30% LESS THAN WOOD ROOM SERVICE TRAYS



Capri Laminated Tray with Smooth Surface



Laminate construction with a smooth surface. Available as rectangular and round tray shapes. To order Charcoal Granite add E82 to the item code, for Birch add E75, for Mahogany add E73, for Dark Oak add E88, for Light Oak add E86 and for Light Olive add E89.

CA2836	Rectangle	280 x 360mm
CA3253	Rectangle	325 x 530mm

CA3343	Rectangle	330 x 430mm
CA3446	Rectangle	340 x 460mm

CA3646	Rectangle	360 x 460mm
CA3748	Rectangle	370 x 480mm



SPECIFICATION	
SURFACE CHARACTERISTICS	SMOOTH
PERFORMANCE	GOOD
STACKING LUGS	NO
DISHWASHER SAFE	YES - NORMAL
CHEMICAL RESISTANCE	EXCELLENT
DRYING TEST	GOOD
SHOCK RESISTANCE	GOOD
BREAK RESISTANCE	GOOD
SCRATCH RESISTANCE	GOOD
STAIN RESISTANCE	EXCELLENT
HEAT RESISTANCE	-10° TO +100°C*

TRAYS

Mykonos Laminated Tray with Non-Slip Surface



Laminate construction with a non-slip surface. Available as rectangular and round tray shapes. To order Birch add E75 to the item code, for Mahogany add E73 and for Walnut add E76.

MY3343	Rectangle	330 x 430mm
--------	-----------	-------------

MY3646	Rectangle	360 x 460mm
--------	-----------	-------------

MY3800	Round	Ø380mm
--------	-------	--------



SPECIFICATION	
SURFACE CHARACTERISTICS	NON-SLIP SURFACE
PERFORMANCE	GOOD
STACKING LUGS	NO
DISHWASHER SAFE	NO
CHEMICAL RESISTANCE	GOOD
DRYING TEST	GOOD
SHOCK RESISTANCE	GOOD
BREAK RESISTANCE	GOOD
SCRATCH RESISTANCE	GOOD
STAIN RESISTANCE	GOOD
HEAT RESISTANCE	-10° TO +100°C*

Versa Century Wood Grain Trays

WARRANTY
5
YEARS

new

The Century Wood Grain tray combines the authentic look of wood grain with lasting durability, making it ideal for use in high traffic self-serve restaurants with modern rustic décor. The textured wood grain pattern covers the tray from edge to edge and top and bottom for a real wood look and feel. Available with textured smooth, textured clear or rubber non-slip surface.

TRAYS



Textured Smooth Surface

VTC3343T	330 x 430mm
VTC3646T	355 x 457mm
VTC3253T	325 x 530mm

Textured Clear Non-Slip Surface

VTC3343TNS	330 x 430mm
VTC3646TNS	355 x 457mm
VTC3253TNS	325 x 530mm

SPECIFICATION	
SURFACE CHARACTERISTICS	SMOOTH/NON-SLIP
PERFORMANCE	EXCELLENT
STACKING LUGS	YES
DISHWASHER SAFE	YES - EXTENSIVE
CHEMICAL RESISTANCE	EXCELLENT
DRYING TEST	EXCELLENT
SHOCK RESISTANCE	EXCELLENT
BREAK RESISTANCE	EXCELLENT
SCRATCH RESISTANCE	EXCELLENT
STAIN RESISTANCE	EXCELLENT
HEAT RESISTANCE	-40° TO +90°C



Versa Lite Polyester Tray with Smooth Surface



ADD YOUR
LOGO SEE
PAGE 225

SMC - Standard performance fibreglass and reinforced polyester construction with a smooth surface. Available in a variety of shapes and colours.



SPECIFICATION	
SURFACE CHARACTERISTICS	SMOOTH
PERFORMANCE	EXCELLENT
STACKING LUGS	YES
DISHWASHER SAFE	YES - NORMAL
CHEMICAL RESISTANCE	GOOD
DRYING TEST	EXCELLENT
SHOCK RESISTANCE	GOOD
BREAK RESISTANCE	GOOD
SCRATCH RESISTANCE	GOOD
STAIN RESISTANCE	GOOD
HEAT RESISTANCE	-40° TO +130°C

TRAYS

To order a specific colour add the colour code to the end of the item code.

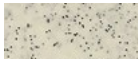

**SPECKLED
SMOKE
A20**



**SPECKLED MOCHA
A21**



**SAHARA
A22**



High Profile Shape
HIGH PROFILE SHAPE KEEPS FOOD
FROM FALLING OFF EDGE.



Low Profile Shape
LOW PROFILE SHAPE ALLOWS FOR
EATING DIRECTLY OFF TRAY.



Flat Edge Shape
FLAT EDGE SHAPE ALLOWS FOR EASY
GRIP AND EASE OF TRANSPORT.

A High Profile Shape	
VL1216	305 x 415mm
VL3343	330 x 430mm
VL1418	360 x 460mm
VL1520	380 x 515mm

B Low Profile Shape	
VL2632	325 x 265mm
VL3253	325 x 530mm
VL3753	370 x 530mm

C Flat Edge Shape	
GL4002	325 x 530mm

Camtrays Fibreglass Trays with Smooth Surface



ADD YOUR
LOGO SEE
PAGE 225

Fibreglass tray with a smooth surface finish.

1418	Rectangle	355 x 455mm
3253	Rectangle	325 x 530mm



SPECIFICATION

SURFACE CHARACTERISTICS	SMOOTH
PERFORMANCE	EXCELLENT
STACKING LUGS	YES
DISHWASHER SAFE	YES - EXTENSIVE
CHEMICAL RESISTANCE	GOOD
DRYING TEST	EXCELLENT
SHOCK RESISTANCE	EXCELLENT
BREAK RESISTANCE	EXCELLENT
SCRATCH RESISTANCE	EXCELLENT
STAIN RESISTANCE	EXCELLENT
HEAT RESISTANCE	-10° TO +100°C*

To order a specific colour add the colour code to the end of the item code.



BLACK
110



WHITE
148



HORIZON BLUE
105



PEARL GREY
107



SHERWOOD GREEN
119



AMAZON BLUE
123



SIGNAL RED
510

Fast Food Polypropylene Tray with Textured Surface



ADD YOUR
LOGO SEE
PAGE 225

Polypropylene tray with a textured surface finish. Available as **A** High Profile Rectangular Shape Tray or **B** High Profile Rectangular Shape Tray with Handles.

1014FF	H. Profile	265 x 345mm
1216FF	H. Profile	300 x 410mm

1418FF	H. Profile	360 x 460mm
1217FFH*	w/ handles	300 x 410mm

* Not available in Navy Blue (186), Blue (168), or Red (163)



SPECIFICATION

SURFACE CHARACTERISTICS	TEXTURED
PERFORMANCE	GOOD
STACKING LUGS	YES
DISHWASHER SAFE	YES - MINIMAL
CHEMICAL RESISTANCE	EXCELLENT
DRYING TEST	GOOD
SHOCK RESISTANCE	GOOD
BREAK RESISTANCE	GOOD
SCRATCH RESISTANCE	GOOD
STAIN RESISTANCE	GOOD
HEAT RESISTANCE	-10° TO +80°C*

To order a specific colour add the colour code to the end of the item code.



BLACK
110



BROWN
167



NAVY BLUE
186



SHERWOOD GREEN
119



RED
163



BLUE
168

Personalise your trays...

Personalised Cambro Trays are a 'walking' advertisement delivered directly to your target audience at the point of purchase. A fraction of the cost of traditional print advertising, Cambro trays offer years of long-lasting promotion with a significantly greater return on investment.



Trays that can be personalised

Polyester Trays - VT/GP & VL/GL

Fibreglass Trays - CAMTRAY

Laminated Trays - Capri, Mykonos, Madeira

Fast Food Tray

CT Trays

How to Order

1. Select a tray size, colour, pattern or design.
2. Minimum order quantity, lead time, printing options, and printable tray area vary depending on the tray type required.
3. Complete digital artwork and indication of preferred positioning on the tray must be provided at the time of ordering.
4. For new projects, a finished sample will be submitted for the customer's approval.
5. Personalisation charges apply to both the original order, any reorders and returns.

PLEASE CONTACT
US FOR FURTHER
INFORMATION &
ADVICE

Featured Brands

CAMBRO
TRUSTED DURABILITY

pujadas
A VOLLRATH COMPANY

san jamar
smart safe sanitary

VOLLRATH

Table Service & Display

The first bite is with the eyes. Beautiful food and drink presentation stimulates appetite and enhances the overall dining experience. For buffets, banqueting, hotels, and restaurants, presentation is everything. Whether you need buffet display equipment or table service displays, our high-quality, stylish range offers the perfect solution for every commercial food display.



Buffet Trolleys	228
Cocktail Trolleys	230
Bucket-holder Stands	231
Champagne Buckets	231
Conical Ice Buckets	231
Acacia Wood Serving Boards	231
Vintage Tableware	232
Bronze Cast Aluminium Cookware	233
Bronze Utensils	233
Cool Line Non-Stick GN Pans	233
Induction Chafers	234
CUBIC Buffet Display	236
Stainless Steel Serving Bowls	238
Deli Crocks, Bowls & Covers	238
Dome Garnish Centres	239
Shoreline Collection	240
Camwear	
Polycarbonate Camcovers	240
Polycarbonate Pitchers	241
Tumblers & Mugs	241

Buffet Trolleys

New buffet trolleys from Pujadas bring elegance to the grab-and-go buffet.

Wo
Wood

CS
Carbon
Steel

new

- Buffet trolley with multiple shelves and spaces compatible with GN sizes.
- Trolley with top module includes three ½ wooden boxes and two 1/1 metal baskets, optimising space and allowing operators to create a complete buffet station.
- The two central shelves have a sloping rear hook, which allows for the shelves to be presented either flat or at an angle.
- Made from premium materials with a high-quality finish.
 - Tubular structure in matte-finished carbon steel.
 - Solid wood tabletop with a formica coating resistant to heat, humidity and wear.
- Versatile work and storage areas.
- Easy anchoring system for quick assembly.
- One handle is included for smooth mobility, with the option to add another to the adjacent side.
- Each trolley comes fitted with black revolving casters, two with brakes.

A



INCLUDES 2 X GN 1/1 WIRE BASKETS & 3 X GN 1/2 WOODEN BOXES

B



INCLUDES 2 X GN 1/1 WIRE BASKETS

Buffet Trolleys

A 90940	With Top Module	1240 x 500 x 1500mm
B 90950	Without Top Module	1240 x 500 x 880mm

Buffet Trolley Accessories

Enhance the functionality of your buffet trolley with a range of optional accessories, designed to customise your service and elevate presentation.



Wooden Shelf

90980 900 x 500 x 40mm



Handle

90971 500 x 130 x 20mm



INSERT INTO HANDLE

Bottle Rack

90970 480 x 105 x 100mm

Service Trolleys

Wo
Wood

CS
Carbon
Steel

new

Designed for versatile professional service and premium presentation.

- Designed to enhance presentation and flow, the central shelves are configured either for flat or inclined display, offering flexibility for any service style.
- Tubular structure crafted from black, matte-finished carbon steel for a sleek, modern look.
- Solid wood worktops are fitted with a durable Formica coating, resistant to heat, humidity, and daily wear. Two or Three-level design for efficient service.
- Versatile work and storage areas.
- Easy anchoring system for quick assembly.
- One handle is included for smooth mobility, with the option to add another to the adjacent side. Each trolley comes fitted with black revolving casters, two with brakes.



Two-level Serving Trolley With solid wood worktop.

A 90960 900 x 500 x 880mm



Three-level Serving Trolleys With solid wood worktop.

B 90961	With Two Flat Shelves (1 Wooden / 1 Carbon Steel)	900 x 500 x 880mm
C 90962	With Two Flat Carbon Steel Shelves	900 x 500 x 880mm
D 90963	With Two Carbon Steel Shelves (1 Flat / 1 Inclined)	900 x 500 x 880mm
E 90964	With Two Inclined Carbon Steel Shelves	900 x 500 x 880mm

Cocktail Trolley

new

TABLE SERVICE & DISPLAY



Elevate your customers' mixology experience with the Pujadas range of stylish, versatile mobile bars, designed for efficient service.

Create unique cocktails on the move with multiple storage spaces and work areas, all supported by a satin-black, anti-rust carbon steel structure and heavy-duty swivel wheels with brakes. Give your customers a cocktail experience to remember!

NEW Cocktail trolley with LED Lighting

Thoughtfully designed smart storage solutions keep tools, bottles, and glassware neatly organised, while integrated hanging bottle racks maximise capacity without compromising accessibility. Dedicated areas for ice and condiments, combined with an internal drainage system, ensure clean, efficient preparation during busy service. The built-in 3000K COB LED lighting adds a refined, ambient glow, enhancing presentation and creating an elegant, inviting atmosphere. Ideal for premium bars, hotels, and events.

A 90915 1325 x 630 x 985mm



Cocktail Trolley with Stainless Steel Work Module

Features smartly arranged compartments, a smooth-glide drawer, five glass-hanging rails, and a side rail for three additional bottle racks. Includes a spacious prep surface, a six-compartment condiment box, internal drainage area, and two 1/3 GN perforated ice trays for efficient cocktail service

B 90910 1325 x 630 x 985mm



Compact Cocktail Trolley

Oak-finish anti-humidity top with hanging rails, rocks-glass storage, and space for up to 20 glasses and mixers. Satin-black, anti-rust carbon steel frame with heavy-duty swivel wheels, two with brakes.

C 90930 915 x 630 x 980mm



Cocktail Trolley Hanging Bottle Rack

D 90911 595 x 120 x 235mm

CUSTOMISE
WITH YOUR
BRAND OR
COMPANY
LOGO



Bucket-holder Stands



Minimalist stainless steel bucket stands for elegant table-side presentation. Strong, stable, corrosion-resistant, and compatible with most single-bottle buckets, it delivers refined style in a compact, space-saving design.



Bucket-holder Stands

311010	Stainless Steel	Ø190 x H700mm
311011	Vintage Gold	Ø190 x H700mm
311012	Vintage Black	Ø190 x H700mm

Champagne Buckets



Stainless steel ice bucket with vintage finish, designed to elevate professional table service. Durable, corrosion-resistant, and easy to maintain, combining elegance with functionality.



Champagne Buckets

972300	Stainless Steel	4L	Ø200 x H210mm
972301	Vintage Gold	4L	Ø200 x H210mm
972302	Vintage Black	4L	Ø200 x H210mm

Conical Ice Buckets

Durable stainless-steel ice buckets designed to elevate drink presentation, finished in stylish exterior colours including Gold, Black, Copper, and Hammered Silver for a touch of colour and sophistication.



HAMMERED EFFECT

Conical Ice Buckets

972201	Gold	4L	Ø210 x H200mm
972202	Black	4L	Ø210 x H200mm
972203	Copper	4L	Ø210 x H200mm
976210	Hammered Silver	4L	Ø210 x H200mm

Acacia Wood Serving Boards

Ideal for buffet and table service, this durable, easy-to-clean acacia wood piece adds warmth and elegance and is perfect for serving charcuterie, cheeses, and meats.

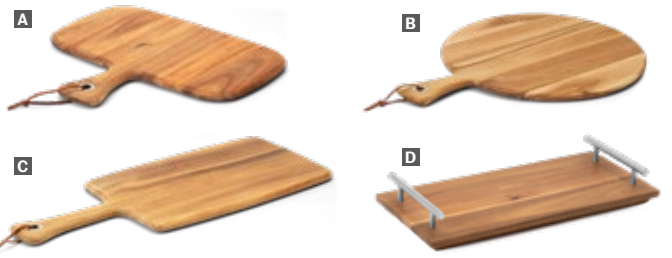

Acacia Wood Serving Boards

A	41008	280 x 305mm
B	41009	405 x 305mm
C	41010	518 x 203mm
D	41011	360 x 175mm

Vintage Tableware

SS
Stainless
Steel

new



Vintage finish: unique and attractive aesthetic with all the advantages of stainless steel.

- Designed for individual dishes, and tapas.
- Highly recommended for table and buffet service.
- Stainless steel finish is suitable for dishwasher use.

TABLE SERVICE & DISPLAY

Vintage Tableware

Bowl

A 24726 155 x 145 x 50mm

Oval Plate

B 24727 300 x 145 x 35mm

Deep Plate

C 24728 225 x 190 x 25mm

Plate

D 24729 270 x 235 x 15mm

Deep Oval Serving Dish

E 24734 260 x 180 x 50mm

Mini Bowl

24740 75 x 75 x 40mm

F 24741 95 x 95 x 40mm

Oval Tray

G 24745 270 x 80 x 10mm

24746 405 x 85 x 10mm

FULL VINTAGE
TABLEWARE
COLLECTION
VISIT FEM.CO.UK



A



B



C



D



E



F



G

Bronze Cast Aluminium Cookware



- Made of cast aluminium with high resistance to deformation.
- Excellent thermal performance.
- Abrasion-resistant anti-adherent.
- Exterior painted in an elegant bronze colour.
- Utensils construction - stainless steel and nylon.



Roast Pan

152035B	Roast Pan Only	350 x 230 x 75mm
152935	Roast Pan Lid	

Deep Casserole without Lid

151020B	Ø200 x H90mm
151024B	Ø240 x H100mm
151028B	Ø280 x H120mm

Bronze Utensils One-piece handles.

33621	Ladle	L330 x W80mm
33622	Solid Spoon	L360 x W70mm
33623	Slotted Spoon	L350 x W70mm
33624	Turner	L350 x W95mm
33625	Spaghetti Server	L347 x W75mm

Shallow Casserole without Lid

141024B	Ø240 x H58mm
141028B	Ø280 x H75mm
141032B	Ø320 x H80mm

Casserole Lid

154020	Ø200mm
154024	Ø240mm
154028	Ø280mm
154032	Ø320mm



Cool Line Non-Stick Gastronorm Pans



GN Colour Non-Stick Pans Give a touch of colour to your buffet. Sturdy construction, made with 18/10 Stainless Steel. Non-stick and sandwich bottom. Full-size or half-size, available in a variety of colours.

1106F3A	Light Orange	1/1 GN	D65mm
1106F3N	Burnt Orange	1/1 GN	D65mm
1106F3R	Red	1/1 GN	D65mm
1106F3G	Grey	1/1 GN	D65mm
1206F3A	Light Orange	1/2 GN	D65mm
1206F3N	Burnt Orange	1/2 GN	D65mm
1206F3R	Red	1/2 GN	D65mm
1206F3G	Grey	1/2 GN	D65mm



Induction Chafers



TABLE SERVICE & DISPLAY



New from Pujadas

- High-quality finish, large glass window and stainless steel in a shiny polished finish.
- Removable lid for easy cleaning.
- Anti-noise plastic stopper to close the lid silently.
- Hydraulic hinge.
- Diffuser base for optimal heat distribution.

SHOWN ON
OPTIONAL STAND



Round Glass-top Chafing Dish Stainless steel construction with crystal glass top. Includes stainless steel pan.

390001 W460 x D560 x H160mm 6L



Round Chafing Stand Strong and robust stainless steel construction. Includes one burner.

390004 W445 x D520 x H235mm



Round Stainless Steel Pan

390007 Ø385 x 65mm



Round Porcelain Pan

390010 Ø385 x 65mm

Induction Chafers



Square Glass-top Chafing Dish Stainless steel construction with crystal glass top. Includes stainless steel pan.

390002 W410 x D500 x H160mm 5.5L



SHOWN ON
OPTIONAL STAND



Square Chafing Stand Strong and robust stainless steel construction. Includes one burner.

390005 W480 x D375 x H235mm



Square Pans

390008	Stainless Steel	335 x 325 x 65mm
390011	Porcelain	335 x 325 x 65mm



Rectangular 1/1 GN Glass-top Chafing Dish Stainless steel construction with crystal glass top. Includes stainless steel pan.

390003 W580 x D500 x H160mm 9L



Rectangular Pans

390009	Stainless Steel	535 x 325 x 65mm
390012	Porcelain	535 x 325 x 65mm



Rectangular Chafing Stand Strong and robust stainless steel construction. Includes two burners.

390006 W660 x D375 x H235mm



10
POWER
LEVELS



SUITABLE FOR USE
WITH ALL
PUJADAS CHAFERS

2 POWER
LEVELS
LO: 160W &
HI: 275W

Induction Chafers Heaters Maintains serving temp. without an open flame.

A 157954	Ø240mm	1000w
B 46115	-	120/230w

CUBIC Buffet Display



Discover the best in buffet presentation...

- Elegant, original and space saving.
- Multiple varied combinations.
- Suitable for dining rooms, buffet and outdoor display.

Buffet Display Kit for Eight Square Bowls



Buffet Display Kit for Eight Square Bowls

905518

Includes:

- 4 cubes with lid.
- 1 crossbar 800mm length.
- 2 displayers for 4 bowls.
- 8 melamine bowls included.
- 1 narrow shelf 800mm.

Buffet Display for 40 x 40 cm Trays

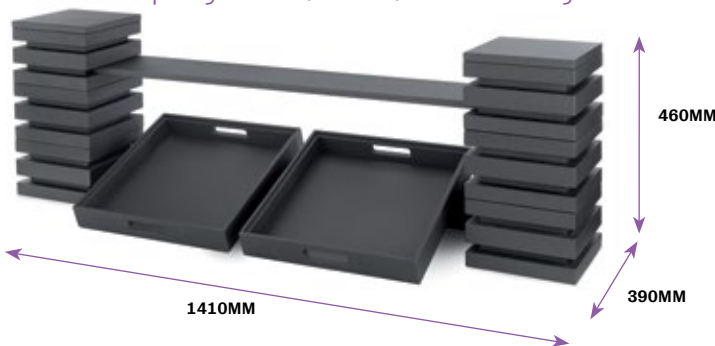

Buffet Display for 40 x 40 cm trays

905310

Includes:

- 6 cubes with lid.
- 1 crossbar 1000mm length.
- 2 serving trays 400 x 400mm.
- 1 narrow shelf 1000mm.

Buffet Presentation Kit



Buffet Presentation Kit

905400

Includes:

- 4 cubes with lid.
- 1 wide shelf 1000mm.
- 1 narrow shelf 1000mm.

L Shape Presentation Kit

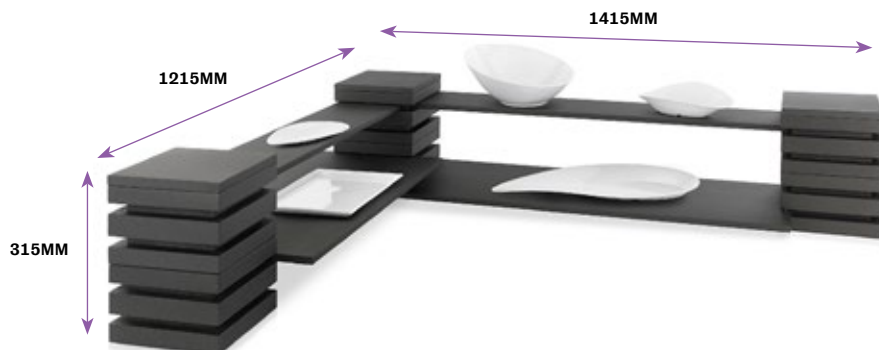

L Shape Presentation Kit

905410

Includes:

- 6 cubes with lid.
- 1 wide shelf 1000mm.
- 1 narrow shelf 1000mm.
- 1 wide shelf 800mm.
- 1 narrow shelf 800mm.

CUBIC Accessories



Cutlery Holder

904780 539 x 335 x 77mm



Serving Tray

904740 400 x 400 x 65mm

904760 600 x 400 x 65mm

904711 1/1 GN D73mm



1/1 GN Wooden Table and Cutting Board

904850 1/1 GN H120mm



Wine Cooler Includes 1/1 GN D150mm.

904155 570 x 370 x 145mm



Roll-top Buffet Display Includes 2 x 1/1 GN D20mm.

904120 370 x 570 x 510mm



Three Level 2/3 GN Display Stands

Includes 3 x GN containers 2/3 D20mm.

904790 650 x 380 x 590mm

Stainless Steel Double Wall Serving Bowls

TABLE SERVICE & DISPLAY



Square Beehive Bowls

47632	1.7L	185 x 185 x 89mm
47634	3L	218 x 218 x 108mm
47635	4.9L	244 x 244 x 131mm
47637	7.8L	299 x 299 x 150mm

Round Beehive Bowls

46587	0.7L	Ø144 x D76mm
46590	1.6L	Ø184 x D103mm
46591	3.2L	Ø241 x D129mm
46592	6.6L	Ø300 x D165mm
46569	9.6L	Ø350 x D175mm

Angled Beehive Bowls

46584	0.95L	Ø188 x D139mm
46585	1.8L	Ø240 x D173mm
46586	3.5L	Ø300 x D209mm
46582	4.7L	Ø350 x D238mm

Deli Crocks, Bowls & Covers

Polycarbonate Pebbled Bowls

Display and serve with these elegant bowls. Made with virtually unbreakable polycarbonate for long-lasting durability.

PSB8	1.7L	Ø203mm
PSB10	3L	Ø254mm
PSB12	5.5L	Ø305mm
PSB15	10.6L	Ø381mm



Deli Crocks Made of SAN for impact, stain, break and chip resistance. Stackable and virtually unbreakable.

DC5	Rectangle	260 x 175 x H80mm
DC10	Rectangle	335 x 265 x H80mm
DC5	Fits DC5	238 x 150 x H35mm
DC10	Fits DC10	310 x 240 x H35mm



Deli Crocks & Cover
PREP, STACK AND STORE ALL-IN-1.
SAVE STORAGE SPACE, AVOID
CROSS-CONTAMINATION & KEEP FOOD
FRESH USING CLEAR COVER WITH
HANDLE. LID CAN ALSO DOUBLE AS
BOTH A RISER IN DISPLAYS OR A
FALSE BOTTOM.

The Dome®

The all-in-one garnish solution designed by bartenders for bartenders. Tailored to fit on standard mixing rails, The Dome® features a patented dome lid that rotates back for easy access and increased capacity when closed. Integrated snap-on caddies store straws, stirrers and picks. The new 2.2L and 1.65L “deep pan” options are double the capacity of competitive units. The Dome® is the perfect solution for garnishes, condiments, toppings and more!



TABLE SERVICE & DISPLAY



A



B



C



D

The Dome®

- A** BD4005S 4.4L (chillable) (1) 2.20L deep tray; (4) 0.55L standard trays; (2) snap-on caddies; (2) handles
- B** BD4006S 3.4L (chillable) (6) 0.55L standard trays; (2) snap-on caddies; (2) handles
- C** BD4004 6.6L (4) 1.65L deep trays; (2) handles

Mini Dome®

- E** BD2002 (1) 1.10L standard tray; (1) connector; (2) end caps, chillable
- BD2003 (2) 0.55L standard trays; (1) connector; (2) end caps, chillable

Dome Stackers

- D** BDS4266 (2) Full-size Domes (1 over 1)

The Dome® Accessories

- BD100S (2) snap-on caddies
- F** B6180 EZ-Chill™ Refreezable Ice Pack (6 Pack)



E

REFREEZABLE ICE PACKS
ALSO AVAILABLE TO KEEP
CONDIMENTS CHILLED



F

Shoreline Collection

Create an extraordinary tray top presentation with the insulated Shoreline Collection! Ideal for healthcare tray service; secure mugs and bowls with tight-fitting disposable or reusable CamLids® for safe and spill-free transportation with Dome Covers for temperature retention of meals for the ultimate meal service solution.

new



Pellet Underliner Holds 9" Plate. Chip and break-resistant. Dishwasher safe. Available in various colours.

MDSL9 Ø243 x H46mm



Domes Chip and break-resistant. Dishwasher safe. Ergonomic handle for easy lifting. Available in various colours. Holds 9" Plate.

A MDSD9 Ø254 x H73mm

MDSL9 Ø258 x H70mm



Mug Chip and break-resistant. Dishwasher safe. Available in various colours. 0.24L capacity.

MDSM8 Ø89 x H102mm



Bowls Chip and break-resistant. Dishwasher safe. Available in various colours.

B MDSB5 Ø89 x H60mm
0.15L

MDSB9 Ø111 x H60mm
0.27L

AVAILABLE IN TWO SIZES

*AVAILABLE IN FOUR COLOURS. ADD COLOUR CODE WHEN ORDERING: BLACK (110), NAVY BLUE (497), SPECKED GREY (480), CRANBERRY (487).

Reusable Lids Use the tight-fitting reusable CamLid® with Shoreline Mugs & Bowls. Dishwasher safe. Pack of 240. Colour code (148) for ordering.

C CLRSB9 For MDSB9 Ø118 x H7.2mm

CLRSM8B5 For MDSM8 & MDSB5 Ø96 x H7.6mm

Reusable Lids Use with Shoreline Mugs & Bowls. Pack of 1000. CLSB9 available in Translucent (190) & CLSSM8B5 in White (148).

D CLSB9 For MDSB9 Ø111 x H7.6mm

E CLSSM8B5 For MDSM8 & MDSB5 Ø18.9 x H17.5mm



Camwear® Polycarbonate Camcovers®

Camwear® Polycarbonate Camcovers® Internal diameter shown. To order Clear add 152 to the item code, for Silver add 486.

806CW Ø214 x H68mm

900CW Ø232 x H70mm

909CW Ø248 x H70mm

9011CW Ø254 x H73mm

1000CW Ø259 x H68mm

1005CW Ø268 x H72mm

1007CW Ø270 x H70mm

1101CW Ø279 x H68mm

1202CW Ø308 x H70mm

- Food stays hot and appetising without re-heating.
- Ideal for use in heated carts.
- Safe up to 99°C.
- Virtually unbreakable polycarbonate will not dent or scratch.
- Lightweight for quiet service.
- Saves on labour with no polishing required.



Pitchers, Tumblers & Mugs

PERSONALISE TUMBLERS, BARWARE, PITCHERS, DECANTERS AND DINNERWARE TO PROMOTE YOUR BRAND OR BUSINESS. GET IN TOUCH FOR MORE INFORMATION.

Camwear® Polycarbonate

Pitchers Crystal clear look and feel of glass but made of virtually unbreakable polycarbonate. Features thumb-grip, ice-control contoured lip.

A P320CW	0.95L
B PC34CW	1 L
P480CW	1.4L
P600CW	1.8L
C PE600CW	1.8L
D P60CW	1.8L
E PC64CW	1.9L



TABLE SERVICE & DISPLAY

SAN Newport Tumblers

Impact-resistant SAN plastic resists chips and breaks. Stacking lugs prevent sticking. Sani-Rim lip provides a sanitary drinking surface.

NT5	189ml
NT8	228ml
NT9	275ml
NT10	300ml
NT12	373ml
NT14	414ml
NT16	485ml



Camwear® Polycarbonate Mugs

Virtually unbreakable Camwear polycarbonate resists stains, odours and scratches.

75CW	239ml
	Stacking Cup
96CW	288ml Mug



FOR MORE CAMBRO DINNERWARE VISIT WWW.FEM.CO.UK

Featured Brands

PRINCECASTLE

san jamar
smart. safe. sanitary.

SERVER VOLLRATH

Dispensing & Serving

When things work well, they become invisible, but when they don't, they quickly become a headache. Accurate dispensing of cups, lids, napkins, and sauces is essential in any quick-service operation. Our user-friendly dispensing and serving solutions help reduce spend and waste while supporting a smart, safe, and sanitary environment. Made from high-quality materials, these versatile products can be countertop, wall-mounted, or free-standing to suit any area of your operation.



IxD Sauce Dispenser Series	244
Narrow Sauce Dispensers	246
Portion Control Dispensers	246
Heavy Sauce Dispensers	246
Ez-Kleen Squeeze Sauce Bottles	247
Salt & Seasoning Dispensers	247
Dry Food Dispensers	248
Napkin Dispensers	249
Sentry Adjustable Cup Dispensers	250
EZ-Fit Cup Dispensers	251
Stainless Steel Cup Dispensers	252
Water Cup Dispensers	253
EZ-Fit In-Counter Lid Dispensers	254
Wall-Mount Lid Dispensers	254
LidSaver 3 Lid Dispensers	255
Service Area Essentials	256
Condiment Organisers & Dispensers	257

Serve Smarter with the IxD™ Sauce Dispenser Series

DISPENSING & SERVING



Presenting the Server IxD™ Series, powered by SmartWares® Technology and engineered to deliver upon Server's Core Four™ Platform – Speed of Service, Efficiency, Consistency and Simplicity. It's not just smart, it's a whole new level of style and operational excellence.

Sauce+ Sauce Dispenser

Single-touch dispensing delivers precise portions of customer's favourite sauce recipes and optimises front-of-house and back-of-house operations within a modular space-saving design.

- Portioning of ambient sauce from direct pour 83oz bin.
- Dispense into portion cup or directly onto menu item.
- Intuitive control panel enables quick menu item selection and dispense and easy product refills.
- Three factory preset recipe portions: Small, Medium and Large plus a push-and-hold free pour button.
- SmartWares® Technology platform has the ability to be IoT enabled with Wi-Fi connectivity for real-time monitoring of key performance metrics.
- User interface prompts when product is low and aids with clean-in-place steps.
- User interface can be customised for specific menu options and portions.



Sauce+ Sauce Dispenser

CODE	DESCRIPTION	CAPACITY	W X D X H
SAUCEPLUS	Direct Pour	2.45L	100 x 450 x 284mm

Single+ and Multi+ Condiment Direct Pour Dispensers

new



SINGLE+ ALLOWS FOR SINGLE CONDIMENT DISPENSING.



MULTI+ CAN DISPENSE UP TO 6 CONDIMENTS FROM A SINGLE AUTOMATED SYSTEM.

- Use as a front-of-house self-serve condiment station or back-of-house for prepping menu items or filling portion cups.
- User friendly interface includes graphics, cleaning prompts and product change instructions.
- Push-and-hold button activation is standard but precise portions can be customised for roll-outs.
- SmartWares® Technology platform has the ability to be IoT enabled with Wi-Fi connectivity for real-time monitoring of key performance metrics.
- Small countertop footprint.

Single+ and Multi+ Condiment Direct Pour Dispensers

CODE	DESCRIPTION	CAPACITY	W X D X H (ABOVE COUNTER)
SINGLEPLUS	Single Countertop Dispenser w/Drip Tray	5.7L	121 x 205 x 296mm
MULTIPLUS	Six Sauce Countertop Dispenser w/Drip Tray	6 x 5.7L	148 x 240 x 413mm

Flavor+ Syrup Dispenser

Dispense precise portions of up to 14 syrup and sauce flavours and maximise workflow with one unit that creates a complete menu of perfectly sweet beverages.

- For back-of-house beverage order preparation.
- Dispense directly from up to 14 food product containers.
- Internal holding racks are configurable for flexibility with different food container types.
- Intuitive control panel enables quick menu item selection and dispense as well as easy product refills and clean-in-place procedure prompts.
- Configurable portions in 1/8oz increments up to 5oz maximum portion.
- SmartWares® Technology platform has the ability to be IoT enabled with Wi-Fi connectivity for real-time monitoring of key performance metrics.



FOR MORE SAUCE AND CONDIMENT PUMP DISPENSING STATIONS PLEASE VISIT FEM.CO.UK

Flavor+ Syrup Dispenser

CODE	DESCRIPTION	CAPACITY	W X D X H
FLAVORPLUS	Sauce & Syrup Dispenser	10 Flavours (4 Thin, 6 Thick)	324 x 537 x 804mm

Narrow Sauce Dispensers

- Available for both mustard and ketchup.
- New narrow design uses less prep table space.
- Capacity: 0.91 kg above refill line.
- Provides improved portion control.
- Positive pump action provides an accurate portion every time.
- Lightweight plastic shell for ease of handling.
- Includes cover with tether attachment to reduce loss.
- Easy calibration – no tools required.
- All internal parts are coloured white and red or white and yellow for ease of identification when purchasing both dispensers.



Narrow Sauce Dispensers

CODE	DESCRIPTION
A 398-CN	Mustard Dispenser
B 406-AN	Ketchup Dispenser



Traex® Sauce Boss® Portion Control Dispenser

2800-31	Sauce Boss® with legs
---------	-----------------------

- Get accurate and consistent portion control.
- Holds up to 48 oz of sauces or dressings.
- Settings from ½ oz to 1/32 oz.
- Position adjustment is easy, pull the cam pin and rotate the cam to the desired setting.
- Clear lid helps reduce the risk of food contamination.



Traex® Batter Boss® Portion Control Dispenser

2803-18	Batter Boss® with legs
---------	------------------------

- Easily dispense pancake, waffle or hush puppy batters.
- 8 portion control settings dispense from 1–3 oz.
- Not recommended for chunky batters.
- Position adjustment is easy, pull the cam pin and rotate the cam to the desired setting.
- Clear lid helps reduce the risk of food contamination.



Heavy Sauce Dispensers* Portion control for Mayo, Tartar, Guacamole, Sour Cream and other heavy sauces. Dispenser bottles and bottle storage trays also available.

C 580-NMCC	1/3oz Dispenser
581-NMCC	1/2oz Dispenser
D 136-1	Bottles (9pk)
E 155	Bottle Tray

* DISPENSER BOTTLES SOLD SEPERATELY. ORDER 136-1 REUSABLE BOTTLES IF NOT USING PRE-PACKAGED SAUCES.



C

D E

Ez-Kleen Sauce Bottles

A Better First-In, First-Out Solution to streamline plating and food-prep sauce dispensing solution that is easy to use, clean, and affordable.

- **Interchangeable Caps for Easy Evening Storage:** Switching from valve to solid caps effectively reduces waste, and cuts both prep and clean-up times.
- **First-In, First-Out Design:** Bottom dispensing design ensures proper food rotation.
- **Easy To Use:** Unique smooth side walls and same-sized openings on both ends make filling, dispensing, and cleaning a breeze.
- **Improved Portions and Presentation:** Valve design reduces splatter to make portions more consistent and enhance food presentation.
- **Guided By Gravity:** Gravity directs contents toward the leak-resistant valves.
- **The Perfect Fit:** Solid and valved caps conveniently fit both ends of the bottle.
- **Strong Construction:** Durable polyethylene and NSF certified.
- EZ-KLEEN sauce bottles are now available in 12-, 16-, 20-, and 24-ounce sizes with three valve options for thin-to-thick sauce dispensing:
 - Green valve for thin sauces like balsamic vinegar.
 - Yellow value for more viscous sauces like mayonnaise.
 - Blue valve for thicker sauces like tartar sauce.



Ez-Kleen Colour-Coded Caps

Six pack, assortment of colours.

CODE	DESCRIPTION
8573CSC	For 12 & 16oz Bottles
8573CC	For 20oz Bottles
8573CLC	For 24oz Bottle

Ez-Kleen Sauce Bottles

CODE	DESCRIPTION	VALVE
857312S	12oz / 241ml	Green (Thin Sauces)
857316S	16oz / 455ml	Green (Thin Sauces)
857320S	20oz / 568ml	Green (Thin Sauces)
857324S	24oz / 682ml	Green (Thin Sauces)
857312M	12oz / 241ml	Yellow (Viscous Sauces)
857316M	16oz / 455ml	Yellow (Viscous Sauces)
857320M	20oz / 568ml	Yellow (Viscous Sauces)
857324M	24oz / 682ml	Yellow (Viscous Sauces)
857316L	12oz / 241ml	Blue (Thicker Sauces)
857316L	16oz / 455ml	Blue (Thicker Sauces)
857320L	20oz / 568ml	Blue (Thicker Sauces)
857324L	24oz / 682ml	Blue (Thicker Sauces)

InSeason™ Salt & Seasoning Dispensers

- Ensure precise ingredient portions, consistent flavour and nutritional accuracy with each dispense.
- Handheld, high-temp and durable design - keep it where you need it for quick and easy service.
- Includes three colour-coded interchangeable portion triggers.
- Spread Pattern – dispenses evenly over a fry dump or platter.
- Drop Pattern – dispenses over a single hamburger or deli sandwich.



InSeason™ Salt & Seasoning Dispensers

CODE	DESCRIPTION
87100	Spread Pattern
87090	Drop Pattern

Dry Food Dispensers

- Display and dispense accurate portions of dry food quickly.
- 15 portion sizes to choose from.
- Each dispenser needs just 127mm of wall space and includes wall mount bracket.
- 1 or 2 litre capacity hopper in a single, double or triple wall mount configuration.
- Dispense between 7 and 60ml by volume, adjustable in 3.4ml increments.

Dry Food Dispensers

CODE	DESCRIPTION	W X D X H
86670	1 Litre Single	119 x 160 x 345mm
86650	1 Litre Triple	373 x 160 x 345mm
86680	2 Litre Single	119 x 160 x 443mm
86660	2 Litre Triple	373 x 160 x 443mm



SlimLine™ Dry Food Dispensers

- Slim design allows for up to 4 flavours in less than 13" of wall space.
- Improved action capable of handling a wider range of products including powders.
- 2L capacity and holds between 45 and 135 servings depending upon the portion tray used.
- 4 sets of portion trays included for adjusting portion size from ½ fl oz up to 1½ fl oz.
- ADA compliant – does not require a twisting wrist motion or tight grasping to dispense.
- Units available with wall-mount brackets for 1, 2, 3 or 4 units.

SlimLine™ Dry Food Dispensers

CODE	DESCRIPTION	W X D X H
88750	SlimLine™ 2L Single	81 x 176 x 446mm
88760	SlimLine™ 2L Double	175 x 176 x 446mm
88770	SlimLine™ 2L Triple	246 x 176 x 446mm
88780	SlimLine™ 2L Quad	329 x 176 x 446mm



Venue™ In-Counter Napkin Dispenser

- Patented one-at-a-time dispensing reduces napkin waste.
- Control face restricts napkin use, saving up to 30%.
- High Capacity, holds over 750 napkins.
- Ability to convert easily from full fold to interfold napkins.
- Adaptor allows the dispenser to fit into existing counter hole cutouts.
- ABS plastic and 22 gauge stainless steel construction.



DISPENSING & SERVING

A Venue™ In-Counter Napkin Dispenser

CODE	DESCRIPTION	CAPACITY	W x D x H
H2003CLSS	Interfold	750+	178 x 140 x 498mm
H2005CLBK	Fullfold/Control Face	750+	224 x 184 x 515mm

In-Counter Napkin Dispensers

- Space-saving design for under counter, provides a neat, professional appearance.
- Durable.
- One-at-a-time dispensing.
- Face 18-gauge steel and ABS plastic; 22-gauge stainless steel body.

B In-Counter Napkin Dispenser

CODE	DESCRIPTION	CAPACITY	W x D x H
H2000 SS	Minifold	750+	178 x 140 x 498mm
H2001 XC, SS	Fullfold/Classic	750+	178 x 140 x 498mm
H2005CLSS	Fullfold/Control	750+	178 x 140 x 498mm
H2003CLSS	Interfold/Control	750+	178 x 140 x 498mm



Colour Code

CODE	FRONT FACE	FRAME
XC	Chrome	Chrome
CLBK	Clear	Black
CLSS	Clear	Stainless Steel
SS	Stainless Steel	Stainless Steel
SC	Satin Chrome	Satin Chrome

IN-COUNTER NAPKIN COUNTER HOLE DIMENSIONS

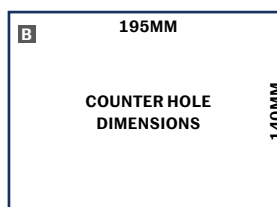
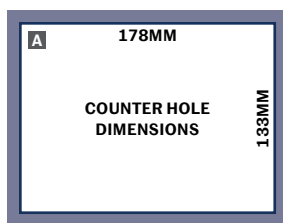

■ WITH ADAPTOR

Choosing your cup dispenser...



Sentry® Adjustable Cup Dispensers combine precise 'one-size-fits-all' dispensing with no wear parts to replace and a variety of smart sanitation features. An attractive trim ring prevents customer tampering and patent-pending features like our lifetime dispensing levers prevent cup damage during loading and dispensing.



EZ-Fit® Cup Dispensers feature an innovative gasket that provide precise, yet smooth dispensing, providing a complete seal around the rim of the cup to help prevent cross-contamination. This dispenser also handles the largest range of cup sizes (1/2 oz to 64oz).



Stainless Steel Cup Dispensers are made to last. Constructed from 26-gauge stainless steel, these dispensers are attractive, durable and built to stand the test of time. Patented adjustable collar easily conforms to your cup size.



NO WEAR PARTS

SIMPLE ADJUSTMENT FOR ANY CUP

PAPER, FOAM OR PLASTIC

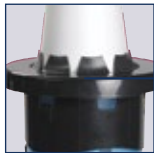

INNOVATIVE CONTAMINATION GUARD PREVENTS DEBRIS FROM ENTERING DISPENSER.



Sentry® Adjustable Cup Dispensers

- Simple: 'set it and forget it' operation provides easy and exact adjustment (even with cups loaded), while attractive trim ring prevents customer tampering.
- Prevents cup damage: Adjustable Lifetime Levers™ are engineered with a revolutionary design that prevents marring of cups, while providing smooth, one-at-a-time dispensing. Lifetime Lever™ angled construction also prevents damage to cups while loading.
- Prevents Contamination: Innovative Contamination Guard prevents debris from entering dispenser and Food Safety Blue transparent tube allows for fast cleanliness check.

One-Size-Fits-All Sentry® Cup Dispenser

CODE	APPROX. CUP SIZE	CUP RIM DIAMETER	TUBE LENGTH
C5450C	8-44oz/236-1301ml	79-114mm	603mm
C5450C18	8-44oz/236-1301ml	79-114mm	457mm

Construction: high-impact plastic.

Euro Sentry® One-Size-Fits-All Cup Dispenser

CODE	APPROX. CUP SIZE	CUP RIM DIAMETER	TUBE LENGTH
C5250C	4-24oz/118-710ml	62-92mm	603mm
C5250C18	4-24oz/118-710ml	62-92mm	457mm

Construction: high-impact plastic.



C5450C COUNTER HOLE DIMENSIONS



C5250C COUNTER HOLE DIMENSIONS

FOR MULTIPLE IN-COUNTER UNITS LEAVE A 184MM SPACE BETWEEN C5450C UNITS AND 159MM SPACE BETWEEN C5250C UNITS.



PREVENT THIS! SENTRY® CUP DISPENSERS WILL NOT DAMAGE CUP EDGES - PREVENTING LEAKS AND SPILLS.

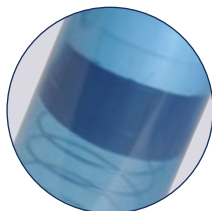

FOOD SAFETY BLUE TRANSPARENT TUBE. ALLOWS FOR A FAST CLEANLINESS CHECK.

EZ-Fit® Cup Dispensers

EZ-Fit® Dispensing – One-at-a-time smooth dispensing with the ease of changing cup sizes without having to change dispensers.

These cup dispensers combine innovative design and superior functionality by utilizing a patented dispensing system, you can easily change cup sizes without having to change dispensers or sacrifice dispensing function. Each EZ-Fit® Cup Dispenser includes a gasket pack to handle a wide range of cup sizes. Available as a counter mount, surface mount or inbox systems.

A One-Size-Fits-All EZ-Fit®

CODE	CUP SIZE	RIM DIAMETER	TUBE LENGTH
C2410C	8-46oz/236-1360ml	73-121mm	597mm
C2410C18	8-46oz/236-1360ml	73-121mm	457mm
C2410SM*	8-46oz/236-1360ml	73-121mm	597mm

Construction: high-impact plastic. * Surface mount model.

B Euro EZ-Fit® offers the benefits of the one-size-fits-all EZ-Fit® in a smaller, more compact footprint.

CODE	APPROX. CUP SIZE	CUP RIM DIAMETER	TUBE LENGTH
C2210C	6-24oz/178-710ml	73-94mm	603mm
C2210C18	6-24oz/178-710ml	73-94mm	457mm
C2210SM*	6-24oz/178-710ml	73-94mm	457mm

Construction: high-impact plastic. * Surface mount model.

C Portion Cup EZ-Fit®

CODE	APPROX. CUP SIZE	CUP RIM DIAMETER	TUBE LENGTH
C2010C	0.5-2.5oz/15-70ml	38-59mm	406mm

Construction: high-impact plastic



C2210C IN USE



C2210SM IN USE



C2010C IN USE

Which stainless steel dispenser do I need?

- 1 Measure the rim diameter of your cup
- 2 Choose cup type
- 3 Choose mounting position
- 4 Select correct item number using your rim diameter

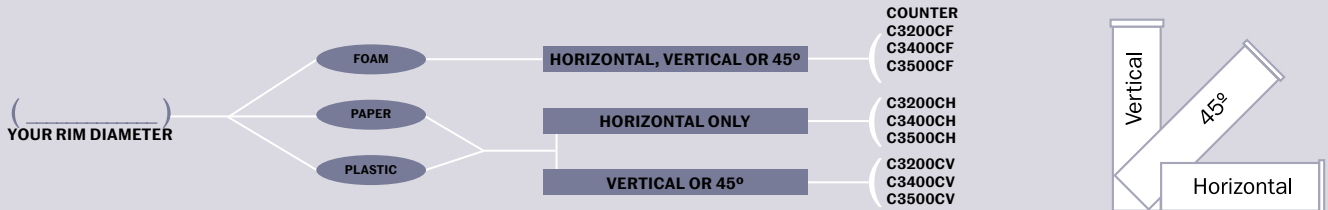

Stainless Steel Cup Dispensers

A Counter-Mount Adjustable Beverage Cup Dispensers

CODE	APPROX. CUP SIZE	CUP RIM DIAMETER	TUBE LENGTH
C3200CF, C3200CH, C3200CV	6-10oz/180-300ml	56-81mm	597mm
C3400CF, C3400CH	12-24oz/350-710ml	70-98mm	597mm
C3500CH	32-46oz/950-1360ml	101-124mm	597mm

Construction: 26-gauge 304 stainless steel; 457mm tube available upon request

B Pull-Type Adjustable Beverage Cup Dispensers

CODE	APPROX. CUP SIZE	CUP RIM DIAMETER	TUBE LENGTH
C3200P	6-10oz/180-300ml	56-81mm	597mm
C3400P	12-24oz/350-710ml	70-98mm	597mm
C3500P	32-46oz/950-1360ml	101-123mm	597mm

Construction: 26-gauge 304 stainless steel; Includes brackets for wall mounting



SHOWN VERTICALLY



SHOWN HORIZONTALLY

Pull-Type Cup Dispensers



A Pull-Type Foam Beverage Cup Dispensers

CODE	APPROX. CUP SIZE	CUP RIM DIAMETER	TUBE LENGTH
C4200PF	4-10oz/120-300ml	70-85mm	597mm
C4400PF	12-24oz/350-710ml	82-98mm	597mm

Construction: C4210PFSD, C4410PFSD: unbreakable polyethylene. C4200PF, C4400PF: 26-gauge 304 stainless steel

Water Cup Dispensers



PRODUCT COLOUR KEY

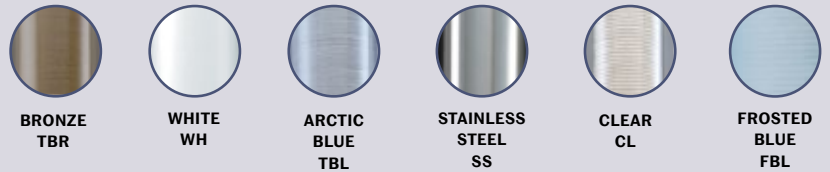

B Small Pull-Type Water Cup Dispensers

CODE	APPROX. CUP SIZE	CUP RIM DIAMETER	TUBE LENGTH
C4150SS	CONE: 90-130ml	57-73mm	406mm
C4160WH	CONE: 90-130ml	57-73mm	406mm
C4160TBL	FLAT: 90-150ml		

Construction: C4150SS: with plastic cap; C3150SSE: with metal cap



C Medium & Large Pull-Type Water Cup Dispensers

CODE	APPROX. CUP SIZE	CUP RIM DIAMETER	TUBE LENGTH
C3165WH	CONE: 120-300ml	64-83mm	406mm
C3165TBL	FLAT: 120-300ml		
C3165FBL			
C3250SS	CONE: 130-210ml, FLAT: 180-350ml	70-86mm	406mm
C3450SS	CONE: 240-350ml, FLAT: 350-710ml	82-98mm	406mm
C3260TBR	CONE: 130-210ml	70-86mm	406mm
C3260TBL	FLAT: 180-350ml		

Construction: C3165 & C3260: high-impact plastic; C3250 & C3450: 26-gauge 304 stainless steel

EZ-Fit In-Counter Lid Dispensers

Lids of all sizes are contained and protected in one stylish dispenser, eliminating messy countertops and wasted lids. It's just one more solution for your counter service strategy.

- EZ-Fit® Dispensing – Allows one-at-a-time smooth dispensing of several types of cold-beverage lid sizes 8 – 24 oz. without having to change dispensers.
- Sanitary Loading – One-handed front loading operation eliminates messy stacks to prevent waste.
- Simple Design – Cabinets require no adjustment and few parts for minimal maintenance.
- High-Impact Plastic – Easy-to-clean plastic with black trim rings resists cracking and breaking for extended use.



EASY SINGLE LID DISPENSING



SIMPLE DESIGN FOR EASY, ONE-HANDED OPERATION

A In-Counter Lid Dispensers

CODE	LID RIM DIAMETER	APPROX. CUP SIZE	TUBE LENGTH
L2200C	70–95mm	8–24oz/236–710ml	603mm
L2400C	95–114mm	24–46oz/710–1360ml	603mm

CONSTRUCTION: HIGH IMPACT PLASTIC



COUNTER HOLE DIMENSIONS



Wall-Mount Lid Dispensers

- Single Lid Option – Accommodates one sleeve of beverage cup lids ranging from 6 – 1 oz.
- Front-Loading – Provides easy access and quick refilling of lids in high-traffic environments.
- Durable Construction – Stainless steel construction is easy-to-clean for extended use.
- Easy Mounting – Attaches to most wall surfaces and is compatible with countertop cup & lid dispenser stand C3604 (sold separately).



STAND C3604

B In-Counter Lid Dispenser

CODE	CAPACITY	MAX. LID Ø	APPROX. LID SIZE	TUBE LENGTH
L3200	1 sleeve	89mm	6–10oz/180–300ml	597mm
L3400	1 sleeve	101mm	12–24oz/350–710ml	597mm

CONSTRUCTION: 22-GAUGE 304 STAINLESS STEEL



EASY SINGLE LID DISPENSING



DURABLE STAINLESS STEEL HINGES

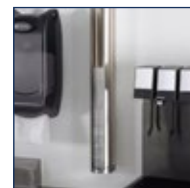

WALL MOUNTED FOR EASY USE

LidSaver 3 Dispenser



LidSaver™ 3 In-Counter Lid Dispensers

- Maximise limited space at busy dispenser stations with the LidSaver™ 3.
- Simple-to-use design allows customers to fill beverages and put on a lid using only one hand.
- Stylish look creates a noticeably more hygienic service in a clean and tidy environment.
- Overload protection added to prevent lids from getting stuck together.

In-Counter Lid Dispenser

CODE	DESCRIPTION	LID DIAMETER	LENGTH	CUT OUT
LS03IB	Horizontal	83 – 95mm	585mm	Ø140mm
LS03IVB	Vertical	83 – 95mm	585mm	Ø140mm
LS03PB	Horizontal	97 – 121mm	585mm	Ø140mm
LS03PVB	Vertical	97 – 121mm	585mm	Ø140mm

Mini In-Counter Lid Dispenser

CODE	DESCRIPTION	LID DIAMETER	LENGTH
LS03MS18B	Horizontal	44–81mm	457mm



LidSaver™ Dispenser Display

Configurable cabinets to dispense a variety of lid types such as cold drink, hot drink, tabbed, domed, contoured, slotted, gourmet coffee, soup cup all in a variety of lid sizes.

Please contact our office for more information.



Also Available



Service Area Essentials

Modular Bulk FIFO Dispenser

- Top loading, bottom dispensing for first-in, first-out use.
- Removable divider to allow horizontal plastic flatware dispensing.
- High capacity condiment dispensing to reduce labour spent refilling.

Modular Bulk FIFO Dispenser

CODE	W X D X H
MODBFD	227 x 306 x 421mm



Coffee Sleeve Dispenser

- Keeps your coffee sleeves organised and conveniently accessible.
- Unique, vertical shape saves valuable counter space.
- Holds 100 sleeves.

Coffee Sleeve Dispenser Black ABS plastic.

CODE	DESCRIPTION	W X D X H
CSLV-1	Vertical	165 x 122 x 251mm



Flush Mount Dispensers

Flush Mount Dispensers Black ABS plastic.

CODE	DESCRIPTION	W X D X H
FMS-7	200 capacity straw dispenser	268 x 114 x 187mm
FMF-3	Flatware holder	165 x 122 x 251mm



In-Counter Dispenser and Trash Chute

A Straw Dispenser

CODE	OUTER DIAMETER	CUT OUT HOLE	TUBE LENGTH
L320C	Ø136mm	106mm	152mm

Construction: 22-gauge 304 stainless steel

B Large Trash Chute

CODE	OUTER DIAMETER	CUT OUT HOLE	TUBE LENGTH
L360C	Ø170mm	153mm	133mm

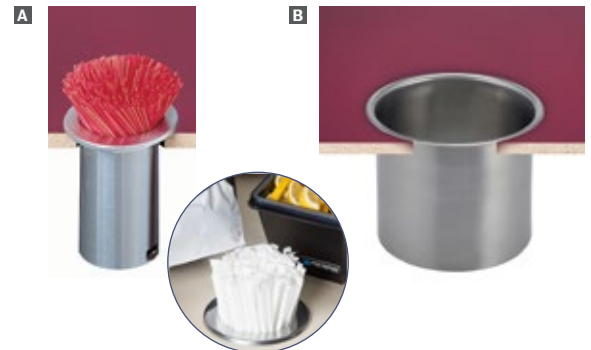

Portion Cup & Lid Organiser

Portion Cup & Lid Organiser Removable dividers for easy cleaning. Non-slip rubber feet. Dishwasher safe. Adjustable to fit 2–3” cups and lids.

CODE	DESCRIPTION	W X D X H
A PCL3ADJ	Adjustable to fit 2–3” cups and lids	290 x 250 x 95mm



Countertop Condiment Organisers

Countertop Condiment Organisers Black ABS plastic and smoked acrylic.

CODE	DESCRIPTION	W X D X H
B CFIFO-4	4 section condiment holder	422 x 257 x 419mm
C CTCPAN3-6	3 x 1/6 clear plastic pans	195 x 533 x 371mm
D CTC-3X2V	Vertical condiment stand	289 x 270 x 416mm
E CTC-4V	4 high vertical condiment stand	151 x 270 x 527mm



Organisers

Organisers Use to store non-perishable condiments, flatware and napkins. To order Black add 110 to item code or for speckled grey add 480.

CODE	DESCRIPTION	W X D X H
F 6RS6	6-compartment	511 x 488 x 241mm
12RS12	12-compartment	648 x 543 x 362mm
5412CBP	Bin Only	130 x 305 x 110mm

Condiment & Straw Organizer Construction: high impact plastic.

CODE	DESCRIPTION	W X D X H
G L2900	(fits on all Dimensions cabinets)	208 x 637 x 241mm



Bulk Straw Dispensers

Bulk Straw Dispensers High capacity organiser. Removable lid & tray for easy cleaning.

CODE	DESCRIPTION	CAPACITY	W X D X H
ST500	Double-Sided	500	203 x 254 x 200mm
ST250	Single-Sided	250	203 x 254 x 108mm



Terms & Conditions

Guarantee and Liability

Goods supplied by Foodservice Equipment Marketing Ltd are guaranteed in accordance with the terms of the manufacturer's warranty provided with the goods or for 1 year if not stated with the goods. The warranty applies to UK mainland only. Goods are supplied with a commercial warranty only. Foodservice Equipment Marketing Ltd takes no responsibility for goods supplied to domestic settings.

Our warranty does not apply to wear and tear, or if a product has been damaged or misused. Machines returned for repair in warranty where it is found the machine has been abused or has not been used as the machine was designed for will be charged for. This also applies where a machine has not been maintained properly including cleaning and descaling where applicable. Machines returned for repair are not reassembled if on quotation you do not require the machine repaired. Loan machines are not available.

Foodservice Equipment Marketing Ltd accepts no liability of whatever nature arising as a result of any representations, breach of contract, late delivery of product, negligence or otherwise including but not limited to any liability for indirect or consequential loss, or loss of profits, revenue, business or goodwill except for liability for death or personal injury by Foodservice Equipment Marketing Ltd's negligence. All conditions, warranties, guarantees and representations, express or implied, by statute, common law or otherwise in relation to the goods (other than any liability which Foodservice Equipment Marketing Ltd is not permitted by law to exclude or restrict) are hereby excluded.

Damages and Shortages

If any order is received short or damaged, notification must be received in writing within 24 hours of delivery (to allow for carrier claims). If external packaging is damaged on delivery, reject the delivery or sign for 'as damaged' on delivery note. Photographic evidence of the damage is required. If an item is reported damaged, do not dispose of packaging.

Returns

- 1) No goods are accepted for return after 30 days. All goods returned are at the sender's expense and responsibility.
- 2) You will require a returns authorisation reference to return any item from our catalogue. You must telephone our office on 01355 244111 to be issued with an authorisation reference before returning goods.
- 3) Foodservice Equipment Marketing Ltd reserves the right to impose an administration charge on all returns.
- 4) Unrequired goods for credit must be in perfect condition and in original packaging. A 15% restocking charge will apply.
- 5) Full purchase detail i.e. our order number, must be included on all returns. Serial numbers are required for the return of equipment lines.
- 6) No special items (non-stock lines and parts) will be accepted back for credit.

Credit Terms

Credit terms are strictly subject to approval, and are subject to change. Strictly 30 days end of the month, from the date of invoice. Foodservice Equipment Marketing Ltd may charge interest on any amount not received by the due date.

The title of the goods will not pass to the purchaser until the goods are paid for in full.

We operate a policy of continuous product development and improvement and from time to time, may alter the specification of items shown in the catalogue.

We reserve the right to change our prices without prior notification. All orders are subject to Foodservice Equipment Marketing Ltd's trading terms and no other terms including customer purchase terms apply unless expressly agreed by Foodservice Equipment Marketing Ltd in writing.

Changes

Every effort is made to prevent printing errors in the catalogue. Any error will be advised at the time of ordering so that we can proceed with corrected details and prices.

Acacia Wood Serving Boards	231	Chillers - Undercounter	122	Fast Food Trays	224
Adjustable Cup Dispensers	250-252	Citrus Juicers	44-45	Filtration Systems - Ice Machines	119
Air & Surface Sterilisers	199	Citrus Wedger	29	Firelighter Pack	204
Air Fryers	55	Clamshell Grill	72	Flake Ice makers	115
Allergen Baking Mats	207	Cleaning Gloves	197	Flame Resistant Gloves	195-196
Allergen Food Preparation Tools	206-207	Cocktail Trolleys	230	Flatware Baskets	141
Allergen Food Storage	173	Coffee Sleeve Dispensers	256	Flush Mount Dispensers	256
Allergen Utensils	207	Cold Resistant Gloves	194-195	Foldable Trolleys	155
Bag Sealers	26	ColdFest Pans	170	Food Blenders	10-11
Bagel Slicer	28	Cold Condiment Dispensers	256-257	Food Delivery Bags	106-109
Bain Bain Marie - Drop-in	86	Condiment Organisers	256-257	Food Delivery Carts	96-98
Bain Maries - Stainless Steel	163	Contact Grills	72	Food Mixers	8-13
Bain-Marie Warmers	91	Contact Toasters	75	Food Packaging Equipment	23-26
Bakery Front Loaders	103	Convection Ovens	52	Food Processors	12-13
Baking - Oven Grids	191	Conveyor Toasters	74	Food Storage Boxes - Polycarbonate	170
Baking - Wire Grates	190	Cook & Hold Ovens	60-63	Food Trolleys	153-156
Baking Pans & Sheets	190-191	Cookware	180-189	Food Warmers	91-93
Baking Tray Trolley	153	Cookware - Black Pro	189	Freezer Gloves	194
Banquet Carts	85	Cookware - Black Series	188	Freezers - Bakery Solutions	126
Bar Blenders	33-34	Cookware - Inox First	180-181	Freezers - Gastro Counters	127
Bar Garnish Stations	239	Cookware - Inox Pro	182-183	Freezers - Floorstanding	123-126
Bar Trays	218-219	Cookware - Stainless Steel	180-184	Freezers - Undercounter	122
Beverage Delivery Containers	100, 104	Cool Line Non-Stick Gastronorm Pans	233	Frozen Drink Machines	41
Blast Chillers	128, 129	Countertop Mixers	14, 15	Fry Pans	181, 185, 186
Blender Container Rinsers	38	CUBIC Buffet Display	236-237	Garnish Centres - Dome	239
Blenders - Beverages	33-37	Cup & Lid Organisers	257	Gastronorm - Adaptor Bars	162
Blenders - Culinary	10-11	Cup Dispensers	250-253	Gastronorm - Polinorm Lids	162
Bottle Holders/Buckets	231	Cup Racks - Camracks	140	Gastronorm - Wire Grates	162
Bowls - Display	238	Cut Resistant Gloves	197	Gastronorm Accessories - GN First	160
Bronze Cookware & Utensils	233	Cutlery Boxes	141	Gastronorm Accessories - GN PRO	162
Buffet Trolleys	228-229	Cutlery Catchers	198	Gastronorm Food Pans	160-170
Bun Pans	190	Cutlery Cylinders	141	Gastronorm Food Pans - SafeTrak Colour	169
Bun Toasters	75-76	Cutting Boards	206	Gastronorm Food Trolleys	153, 154
Burger Press - Smash Burgers	203	Dedicated Holding Bins	80	Gastronorm Pans - Display	233
Burger Presses	19	Deep Fryer - Induction	68	Gastronorm Pans - GN First SS	160
Bussing Boxes	141	Deli Crocks & Bowls	238	Gastronorm Pans - GN PRO SS	161-162
Camracks	138-140	Delivery Backpacks	107, 109	Gastronorm Pans - High Heat	164-165
Camracks Base Racks & Accessories	140	Delivery Bags	106-109	Gastronorm Pans - Polycarbonate	166-167
CamRound Storage Containers	171	Delivery Boxes	103, 104	Gastronorm Pans - Polypropylene	168
Camshelving	144-153	Dicers - Vegetables	28-29	Gastronorm Size Guide	163
Camshelving - Trolleys	153	Digital Scales	214-215	Glass Racks	139
CamSquares Storage Containers	172-173	Dish Caddies	157	Gloves	194-197
Can Openers	202	Dishers	209	GoBag Delivery Bags	106-107
Carving Stations	87	Dishwasher Trolleys	154, 157	GoBox Accessories	105
Casserole Pots	180, 182, 188	Dishwashers	134-137	GoBox Insulated Food Carriers	102-104
Catering Bags	107, 108	Dome Garnish Centres	239	Grill Accessories	202
Catering Food Carts	96-98	Dough Boxes	175	Grill Stones	202
Catering Trays	218-225	Dough Mixers	21	Grill Trays - Black Series	189
Catering Trolleys	153-156	Dough Rollers	21	Grill Trays - GN	190
Cereal Dispensers	248	Drawer Warmers	82-83	Handheld Mixers	8-9
Chafer Heaters	235	Drink Blenders	33-37	Heat Pad - Delivery Bags	109
Chafers	234-235	Drink Dispensers	41-42	Heat Protection Apron	196
Champagne Buckets & Stands	231	Drinks Mixers	38-39	Heat Protection Hot Pad	196
Charcoal Bags	204	Dry Food Dispensers	248	Heat Protection Silicone Gloves	197
Charcoal Ovens	65	Dunnage Racks	149	Heat Resistant Gloves	194-197
Check Racks	203	Egg Cooker	76	Heat Shades	88-89
Cheese Cuber	29	Egg Pan - Oven	191	Heated Sauce Dispensers	92
Cheese Graters	19	Electric Food Carts	97	High Heat Food Pans	164-165
Chillers - Bakery Solutions	126	Electric Glass Polisher	137	High Performance Blenders	34-37
Chillers - Gastro Counters	127	Electric Glass Washer	137	High Speed Ovens	48-51
Chillers - Floorstanding	123-126	Extended Holding Bins	81	Holding Bins	80-81

Holding Cabinets/Trolleys	84-86
Holding Drawers	82-83
Hospital Food Carts	96-98
Hospital Trays	222-223
Hospitality Trays	218-225
Hot Drink Dispensers	40
Hot Food Wells	86
Ice Buckets - Display	231
Ice Caddies	177
Ice Caddy Drain Grate	177
Ice Cream Machines	40
Ice Cream Scoops	208
Ice Crushers	44
Ice Machine Accessories	113, 114, 117
Ice Machine Filtration Systems	119
Ice Machines	113-118
Ice Management Tools	176-177
Ice Storage Bins	117
Ice Totes	176
Immersion Blenders	8-9
Induction Buffet Plates	90
Induction Chafers	234-235
Induction Fajita Skillet	70
Induction Units	69-71
Induction Warmers	90-91
Ingredient Bins	175
Insets - Stainless Steel	163
Insulated Food Carriers	100-101
Insulated Food Carts	96-98
Integral Storage Icemakers	114
Janitorial Buckets	198
Juice Dispensers	42
Juicers	44-45
Kitchen Knives	205
Kitchen Safety Gloves	194-197
Kitchen Timers	27
Kitchen Utensils	207-213
Kleen Pails	198
Ladles	210
Lettuce Slicer	28
Lid Dispensers	254-255
Meal Delivery Boxes	103, 104
Meal Delivery Carts	96-98
Measuring Jugs	174
Meat Ageing Fridges	130
Meat Mincers	22
Meat Slicers	16-18
Microwaves	68
Milkshake Machines	38-39
Mixers - Planetary	14-15
Mobile Food Carts	96-98
Mobile Shelving	145, 148
Modular Icemakers	117, 118
Mugs	240-241
Multi-Cook Ovens	56-59
Multi-Purpose Cutters	28-29
Napkin Dispensers	249
Nugget Icemakers	115
Onion Slicers	28-29
Open Grills	64
Oven Gloves/Mitts	194-197

Ozone Sterilisers	199
Paella Pans	181, 183, 187
Pan Grabbers	194
Panini Grills	72
Panini Press - High Speed Ovens	50
Pasta Machines	20
Pasta Sheeters	20
Peg Racks	140
Pitchers - Drinks	241
Pizza Delivery Bags	106, 108
Pizza Delivery Boxes	104
Pizza Oven - High Speed	51
Pizza Ovens	51-54
Pizza Pans	191
Pizza Screens	191
Planetary Mixers	14, 15
Plate Covers	240
Plate Trolleys	155, 157
Potato Chippers	29
Pots & Pans	180-189
Premium Delivery Bags	108-109
Refractory Bricks - Robata Grills	204
Refrigeration - Bakery Solutions	126
Refrigeration - Floorstanding	127
Refrigeration - Gastro Counters	123-126
Refrigeration - Undercounter	122
Rethermalisers	93
Rice Cookers / Warmers	76
Roast Pans	190
Robata Grills	64
Room Service Trays	221-222
Rotisserie Gloves	194
Rotisseries	66-67
Rubber Floor Mats	198
Sauce Dispenser - Touch	244-245
Sauce Dispensers	244-247
Sauce Dispensers - Handheld	246-247
Sauce Warmers	92
Saucepans	181, 183, 188
Scales	214-215
Scoops - Ice Safety	176
Scoops - Polycarbonate	175
Seasoning Dispensers	247
Service Area Essentials	256-257
Service Trolleys	154-157
Serving Bowls	230
Serving Spoons	213
Shelving	144-152
Shelving - Basic Plus Series	144-145
Shelving - Dividers Bars & Shelves	149
Shelving - Drying Racks	149
Shelving - Dunnage Racks	149
Shelving - Elements Xtra Mobile	145
Shelving - Elevation Series Wall Shelving	150-151
Shelving - Mobile Units	145, 148
Shelving - Pegboards	151
Shelving - Premium Series	146-148
Shelving - Universal Storage Rack	152
Shelving - Wall Shelves	149-150
Shock Chillers	128
Shoreline Collection	240

Slicers	16-18
Smoker Cook & Hold Ovens	63
Softspoons	213
Soup Container	100
Soup Kettles	93
Sous Vide Equipment	77
Spatulas	213
Speed Ovens	48-51
Spindle Mixers	38-39
Spoodles	211
Squeeze Sauce Dispensers	247
Stackable Ovens	50,51
Stainless Steel Cup Dispensers	252-253
Steam Resistant Gloves	194-196
Sterilisers - UV	26
Stick Blenders	8-9
Stockpots	180, 182, 184, 188
Storage Containers	169-173
Storage Containers - Allergen	173
Storage Containers - CamRounds	171
Storage Containers - CamSquares	172-173
Straw Dispensers	248
Tab Grabbers	203
Tableware - Healthcare	240
Tableware - Vintage Collection	232
Temperature Maintenance Tools	99
Timers	27
Toasters	74-75
Tomato Slicers	28
Tongs	212
Trash Chute	248
Tray Racks	140
Trays	218-225
Trays - Fast Food	224
Trays - Fibreglass	218-219
Trays - Laminated	220-221
Trays - Personalisation	225
Trays - Polyester	223
Trays - Polypropylene	224
Trays - Wood Effect	220-222
Trolleys	153-156
Trolleys - Buffet	228-229
Tumblers	241
Undercounter Icemakers	113
Vacuum Packers	23-25
Vegetable Processors	12
Vegetable Slicer	12, 28, 29
Venix Air Fryer	55
Vintage Bottle Holders/Buckets	231
Vintage Tableware	232
Wall Shelves	149-150
Washers	134-137
Water Cup Dispensers	253
Wedgers - Citrus	29
Weighing Scales	214-215
Whisks	213
Wine Buckets	231
Wine Coolers	131
Wood Serving Boards	231
Wrapping Machines	26

F O O D *s e r v i c e* TM
E Q U I P M E N T M A R K E T I N G

